

# ECX-3000 PEG USER

14th Gen Intel® Core™ i9/i7/i5/i3 AI Computing System  
Workstation-grade, NVIDIA®/AMD Graphics, 4 PCIe

# Manual

# Record of Revision

---

| Version | Date       | Page                     | Description      | Remark |
|---------|------------|--------------------------|------------------|--------|
| 1.00    | 2023/5/29  | All                      | Official Release |        |
| 1.10    | 2023/9/8   | 28, 33                   | Update           |        |
| 1.20    | 2024/5/24  | v, 2, 3, 5, 7, 9, 13, 15 | Update           |        |
| 1.30    | 2024/7/8   | All                      | Update           |        |
| 1.31    | 2024/10/22 | All                      | Update           |        |

# Disclaimer

This manual is released by Vecow Co., Ltd. for reference purpose only. All product offerings and specifications are subject to change without prior notice. Vecow Co., Ltd. is under no legal commitment to the details of this document. Vecow shall not be liable for direct, indirect, special, incidental, or consequential damages arising out of the use of this document, the products, or any third party infringements, which may result from such use.

# Declaration of Conformity

**FCC** This equipment has been tested and found to comply with the limits for a Class A digital device, pursuant to part 15 of the FCC Rules. These limits are designed to provide reasonable protection against harmful interference when the equipment is operated in a commercial environment. This equipment generates, uses, and can radiate radio frequency energy, and if it is not installed and used in accordance with the instruction manual, it may cause harmful interference to radio communications. Operation of this equipment in a residential area is likely to cause harmful interference in which case the user will be required to correct the interference at his own expense.

**CE** The products described in this manual comply with all applicable European Union (CE) directives if it has a CE marking. For computer systems to remain CE compliant, only CE-compliant parts may be used. Maintaining CE compliance also requires proper cable and cabling techniques.

# Copyright and Trademarks

This document contains proprietary information protected by copyright. No part of this publication may be reproduced in any form or by any means, electric, photocopying, recording or otherwise, without prior written authorization by Vecow Co., Ltd. The rights of all the brand names, product names, and trademarks belong to their respective owners.

# Order Information

---

| Part Number    | Description   |
|----------------|---|
| ECX-3800-PEG   | ECX-3800-PEG, 4 2.5G RJ45 LAN with PoE+, 2 GigE LAN, 4 Front-access SSD trays, 2 PCIe x8, 2 PCIe x4, 6 USB 3.2, 1 USB Type C, 4 COM, 32 Isolated DIO, 1 System Fan  |
| ECX-3600-PEG   | ECX-3600-PEG, 4 2.5G RJ45 LAN with PoE+, 2 GigE LAN, 4 Front-access SSD trays, 2 PCIe x8, 1 PCIe x4, 6 USB 3.2, 1 USB Type C, 4 COM, 32 Isolated DIO, 1 System Fan  |
| ECX-3400-PEG   | ECX-3400-PEG, 4 2.5G RJ45 LAN with PoE+, 2 GigE LAN, 4 Front-access SSD trays, 1 PCIe x16, 1 PCIe x4, 6 USB 3.2, 1 USB Type C, 4 COM, 32 Isolated DIO, 1 System Fan |
| ECX-3200MX-PEG | ECX-3200MX-PEG, 4 2.5G M12 LAN with PoE+, 2 GigE LAN, 2 Front-access SSD trays, 1 PCIe x16, 6 USB 3.2, 1 USB Type C, 4 COM, 32 Isolated DIO, 1 System Fan           |
| ECX-3200-PEG   | ECX-3200, 4 2.5G RJ45 LAN with PoE+, 2 GigE LAN, 2 Front-access SSD trays, 1 PCIe x16, 6 USB 3.2, 1 USB Type C, 4 COM, 32 Isolated DIO, 1 System Fan                |
| ECX-3100-PEG   | ECX-3100-PEG, 2 GigE LAN, 2 Front-access SSD trays, 1 PCIe x16, 6 USB 3.2, 1 USB Type C, 4 COM, 16 GPIO, 1 System Fan   |

# CPU List

| Series                         | CPU        | Cores | GHz | TDP (W) | ECC |
|--------------------------------|------------|-------|-----|---------|-----|
| Intel®<br>Core™<br>(14th Gen)* | i9-14900   | 24    | 5.8 | 65      | Y   |
|                                | i7-14700   | 20    | 5.4 |         |     |
|                                | i5-14500   | 14    | 5   |         |     |
|                                | i3-14100   | 4     | 4.7 |         |     |
|                                | i9-14900T  | 24    | 5.5 | 35      |     |
|                                | i7-14700T  | 20    | 5.2 |         |     |
|                                | i5-14500T  | 14    | 4.8 |         |     |
|                                | i3-14100T  | 4     | 4.4 |         |     |
| Intel®<br>Core™<br>(13th Gen)  | i9-13900E  | 24    | 5.2 | 65      |     |
|                                | i7-13700E  | 16    | 5.1 |         |     |
|                                | i5-13500E  | 14    | 4.6 |         |     |
|                                | i3-13100E  | 4     | 4.4 |         |     |
|                                | i9-13900TE | 24    | 5   | 35      |     |
|                                | i7-13700TE | 16    | 4.8 |         |     |
|                                | i5-13500TE | 14    | 4.5 |         |     |
|                                | i3-13100TE | 4     | 4.1 |         |     |
| Intel®<br>Core™<br>(12th Gen)  | i9-12900E  | 16    | 5   | 65      |     |
|                                | i7-12700E  | 12    | 4.8 |         |     |
|                                | i5-12500E  | 6     | 4.5 |         |     |
|                                | i3-12100E  | 4     | 4.2 |         |     |
|                                | i9-12900TE | 16    | 4.8 | 35      |     |
|                                | i7-12700TE | 12    | 4.7 |         |     |
|                                | i5-12500TE | 6     | 4.3 |         |     |
|                                | i3-12100TE | 4     | 4   |         |     |

\* 14th Gen support PC Client use condition only.

## Optional Accessories

| Part Number        | Description   |
|--------------------|---|
| DDR5 48G           | Certified DDR5 48GB 5600MHz RAM   |
| DDR5 32G           | Certified DDR5 32GB 4800/5600MHz RAM  |
| DDR5 24G           | Certified DDR5 24GB 5600MHz RAM   |
| DDR5 16G           | Certified DDR5 16GB 4800/5600MHz RAM  |
| DDR5 8G            | Certified DDR5 8GB 4800/5600MHz RAM   |
| PWA-160WB-WT       | 160W, 24V, 85V AC to 264V AC Power Adaptor with 3-pin Terminal Block(7.62mm pitch), Wide Temperature -30°C to +70°C |
| PWA-180WB          | 180W, 24V, 90V AC to 264V AC Power Adapter with 3-pin Terminal Block (7.62mm pitch)                                 |
| PWA-280WB-WT       | 280W, 24V, 85V AC to 264V AC Power Adaptor with 3-pin Terminal Block(7.62mm pitch), Wide Temperature -30°C to +70°C |
| PWA-330WB          | 330W, 24V, 90V AC to 264V AC Power Adapter with 3-pin Terminal Block (7.62mm pitch)                                 |
| PWS-480W-WT        | 480W, 24V, 90V AC to 305V AC Power Supply, Wide-Temp, IP65  |
| TMK2-20P-100       | Terminal Block 20-pin to Terminal Block 20-pin Cable, 100cm   |
| TMK2-20P-500       | Terminal Block 20-pin to Terminal Block 20-pin Cable, 500cm   |
| TMB-TMBK-20P       | Terminal Board with One 20-pin Terminal Block Connector and DIN-Rail Mounting                                       |
| Rackmount          | 2U Rackmount Kit  |
| DIN Rail           | DIN Rail and VESA Mounting Kit  |
| VESA Mount         | VESA Mounting Kit   |
| M.2 Storage Module | M.2 Key M/Key B PCIe Storage Module   |
| 5G Module          | 5G Module with Antenna  |
| 4G Module          | 4G/GPS Module with Antenna  |
| WiFi & Bluetooth   | WiFi & Bluetooth Module with Antenna  |

# Table of Contents

|                  |  |           |
|------------------|--|-----------|
| <b>CHAPTER 1</b> | <b>GENERAL INTRODUCTION</b>              | <b>1</b>  |
| 1.1              | Overview                                 | 1         |
| 1.2              | Features                                 | 2         |
| 1.3              | Product Specification                    | 3         |
| 1.3.1            | Specifications of ECX-3800 PEG           | 3         |
| 1.3.2            | Specifications of ECX-3600 PEG           | 5         |
| 1.3.3            | Specifications of ECX-3400 PEG           | 7         |
| 1.3.4            | Specifications of ECX-3200MX PEG         | 9         |
| 1.3.5            | Specifications of ECX-3200 PEG           | 11        |
| 1.3.6            | Specifications of ECX-3100 PEG           | 13        |
| 1.4              | Supported CPU List                       | 15        |
| 1.5              | Mechanical Dimension                     | 16        |
| 1.5.1            | Dimensions of ECX-3800 PEG               | 16        |
| 1.5.2            | Dimensions of ECX-3600 PEG               | 16        |
| 1.5.3            | Dimensions of ECX-3400 PEG               | 17        |
| 1.5.4            | Dimensions of ECX-3200MX PEG             | 17        |
| 1.5.5            | Dimensions of ECX-3200 PEG               | 18        |
| 1.5.6            | Dimensions of ECX-3100 PEG               | 18        |
| <b>CHAPTER 2</b> | <b>GETTING TO KNOW YOUR ECX-3000 PEG</b> | <b>19</b> |
| 2.1              | Packing List                             | 19        |
| 2.1.1            | ECX-3800 PEG Packing List                | 19        |
| 2.1.2            | ECX-3600 PEG Packing List                | 20        |
| 2.1.3            | ECX-3400 PEG Packing List                | 21        |
| 2.1.4            | ECX-3200MX PEG Packing List              | 22        |
| 2.1.5            | ECX-3200 PEG Packing List                | 23        |
| 2.1.6            | ECX-3100 PEG Packing List                | 24        |
| 2.2              | Front Panel I/O Functions                | 25        |
| 2.3              | Rear Panel I/O & Functions               | 34        |
| 2.4              | Main Board Expansion Connectors          | 44        |
| 2.5              | Main Board Jumper Settings               | 62        |

|                   |  |            |
|-------------------|--|------------|
|                   | 2.6 Ignition Control                         | 69         |
| <b>CHAPTER 3</b>  | <b>SYSTEM SETUP</b>                          | <b>72</b>  |
|                   | 3.1 Installing CPU                           | 72         |
|                   | 3.2 Installing DDR5 SO-DIMM Modules          | 76         |
|                   | 3.3 Installing Mini PCIe Card                | 79         |
|                   | 3.4 Installing Nano SIM Card                 | 82         |
|                   | 3.5 Installing Removable RTC Battery         | 83         |
|                   | 3.6 Installing PCI/PCI Card                  | 84         |
|                   | 3.7 Installing SSD/HDD                       | 88         |
|                   | 3.8 Installing M.2                           | 89         |
|                   | 3.9 Installing Antenna Cable                 | 93         |
|                   | 3.10 Mounting Your ECX-3000-PEG              | 96         |
| <b>CHAPTER 4</b>  | <b>BIOS SETUP</b>                            | <b>100</b> |
|                   | 4.1 Entering BIOS Setup                      | 100        |
|                   | 4.2 Main Menu                                | 101        |
|                   | 4.3 Advanced Menu                            | 102        |
|                   | 4.4 Chipset Menu                             | 108        |
|                   | 4.5 Security Menu                            | 113        |
|                   | 4.6 Boot Menu                                | 116        |
|                   | 4.7 Save & Exit                              | 116        |
| <b>APPENDIX A</b> | <b>: Isolated DIO/GPIO Guide</b>             | <b>117</b> |
| <b>APPENDIX B</b> | <b>: Software Functions</b>                  | <b>133</b> |
| <b>APPENDIX C</b> | <b>: RAID Functions</b>                      | <b>137</b> |
| <b>APPENDIX D</b> | <b>: Power Consumption</b>                   | <b>143</b> |
| <b>APPENDIX E</b> | <b>: Supported Memory &amp; Storage List</b> | <b>148</b> |



# 1

## GENERAL INTRODUCTION

### 1.1 Overview

Vecow ECX-3000 PEG is a complete function of AI Computing System. Featuring 14th Gen Intel® Core™ processors that run with an Intel®R680E PCH and support max 65W TDP CPU, the ECX-3000 PEG supports NVIDIA®/AMD Graphics cards and provides powerful, flexible, and advanced AI productivity. The ECX-3000 PEG is available in six modules : ECX-3800 PEG, ECX-3600 PEG, ECX-3400 PEG, ECX-3200MX PEG, ECX-3200 PEG and ECX-3100 PEG.

The ECX-3000 PEG packs a variety of LAN ports including 2.5G, 2.5G PoE+, 2.5G PoE+ with X-Coded M12 and GigE LAN, and supports high-speed data transfer up to 20G through USB 3.2 Gen 2x2. With up to 4 PCIe expansion slots, support for DDR5 5200MHz memory up to 96GB, the ECX-3000 PEG offers a robust combination of performance and flexibility to facilitate AIoT applications.

The ECX-3000 PEG supports -20°C to 45°C operation temperature, 12V to 50V wide range power input and software ignition control, making it a perfect solution for Robotic Control, Digital Rail, Smart Manufacturing, Public Security, In-Vehicle Computing, and any Edge AI applications.

## 1.2 Features

- Workstation-grade Platform : Intel® Core™ i9/i7/i5/i3 Processor (14th gen, codename : RPL-S Refresh/RPL-S/ADL-S) running with Intel® R680E PCH supports max 65W TDP CPU
- Supports outstanding AI computing productivity by NVIDIA®/AMD graphics card, up to 200W power budget
- USB 3.2 Gen 2x2 offers a max speed of 20Gbps data transfer
- DC 12V to 50V wide range power input, Software Ignition Control
- 4 Independent 2.5G LAN with 4 IEEE 802.3at PoE+
- 5G/WiFi/BT/4G/LTE/GPRS/UMTS, Supports Intel® vPro, TCC, Time-Sensitive Networking (TSN), and TPM 2.0
- Storage : Max. 4 front-access 2.5" SSD Tray, M.2 Key M

## 1.3 Product Specification

### 1.3.1 Specifications of ECX-3800 PEG

| System             |   |
|--------------------|---|
| Processor          | <ul style="list-style-type: none"> <li>24-core Intel® Core™ i9/i7/i5/i3 Processor (14th gen, Raptor Lake-S Refresh)</li> <li>24-core 13th Gen Intel® Core™ i9/i7/i5/i3 Processor (Raptor Lake-S)</li> <li>16-core 12th Gen Intel® Core™ i9/i7/i5/i3 Processor (Alder Lake-S)</li> </ul> |
| Chipset            | Intel® R680E  |
| BIOS               | AMI   |
| SIO                | IT8786E   |
| Memory             | 2 DDR5 5200MHz SO-DIMM, up to 96GB (ECC/Non-ECC)  |
| I/O Interface      |   |
| Serial             | 4 COM RS-232/422/485 (ESD 8KV)  |
| USB                | <ul style="list-style-type: none"> <li>6 USB 3.2 Gen 2, USB Type A Connector</li> <li>1 USB 3.2 Gen 2x2, USB Type C Connector supports max 20Gbps data transfer (15W, 5V/3A)</li> </ul>   |
| Isolated DIO       | 32 Isolated DIO : 16 DI, 16 DO  |
| LED                | Power, HDD, Wireless, PoE   |
| SIM Card           | 3 External Nano SIM Card Sockets  |
| RTC Battery        | 1 Front-access RTC Battery  |
| Expansion          |   |
| Mini PCIe          | 1 Mini PCIe sockets for PCIe/USB/SIM Card   |
| PCI/PCIe           | 4 PCIe Slot : <ul style="list-style-type: none"> <li>2 PCIe x16 Slot with x8 signal</li> <li>2 PCIe x8 Slot with x4 signal</li> </ul>   |
| M.2                | <ul style="list-style-type: none"> <li>1 M.2 Key B Socket (2280/3042)</li> <li>1 M.2 Key B Socket (2280/3052)</li> <li>1 M.2 Key E Socket (2230)</li> </ul>   |
| Graphics           |   |
| Graphics Processor | Intel® UHD Graphics 770/730 driven by Intel® X <sup>e</sup> Architecture  |
| Interface          | <ul style="list-style-type: none"> <li>1 DVI-I : Up to 1920 x 1080 @60Hz</li> <li>1 HDMI : Up to 1920 x 1080 @60Hz</li> <li>2 DisplayPort : Up to 7680 x 4320 @60Hz/5120 x 2880 @120Hz</li> <li>By requested Graphics Card</li> </ul>   |
| Storage            |   |
| SATA               | 4 SATA III (6Gbps) support S/W RAID 0, 1, 5, 10   |
| M.2                | 1 M.2 Key M Socket (2280, PCIe x4)  |
| Storage Device     | 4 Front-access 2.5" SSD/HDD Tray  |
| Audio              |   |
| Audio Codec        | Realtek® ALC888S-VD, 7.1 Channel HD Audio   |
| Audio Interface    | 1 Mic-in, 1 Line-out  |

| <b>Ethernet</b>                       |  |
|---------------------------------------|--|
| LAN 1                                 | Intel® I219LM GigE LAN supports iAMT   |
| LAN 2                                 | Intel® I210 GigE LAN   |
| <b>PoE</b>                            |  |
| LAN 3                                 | 2.5GigE IEEE 802.3at (25.5W/48V) PoE+ by Intel® I226, RJ45 Connector   |
| LAN 4                                 | 2.5GigE IEEE 802.3at (25.5W/48V) PoE+ by Intel® I226, RJ45 Connector   |
| LAN 5                                 | 2.5GigE IEEE 802.3at (25.5W/48V) PoE+ by Intel® I226, RJ45 Connector   |
| LAN 6                                 | 2.5GigE IEEE 802.3at (25.5W/48V) PoE+ by Intel® I226, RJ45 Connector   |
| <b>Power</b>                          |  |
| Input Voltage                         | DC 12V to 50V Power Input  |
| Power Interface                       | 3-pin Terminal Block : V+, V-, Frame Ground  |
| Ignition Control                      | 16 Mode Software Ignition Control  |
| Remote Switch                         | 3-pin Terminal Block : On, Off, IGN  |
| Surge Protection                      | Up to 80V/1ms Transient Power  |
| <b>Others</b>                         |  |
| TPM                                   | Infineon SLB9670 supports TPM 2.0, SPI Interface   |
| Watchdog Timer                        | Reset : 1 to 255 sec./min. per step  |
| Smart Management                      | Wake on LAN, PXE supported   |
| HW Monitor                            | Monitoring temperature, voltages. Auto throttling control when CPU overheats.  |
| <b>Software Support</b>               |  |
| OS                                    | Windows 10, Linux  |
| <b>Mechanical</b>                     |  |
| Dimension (W x D x H)                 | 260mm x 240mm x 142mm (10.24" x 9.45" x 5.59")   |
| Weight                                | 7.5 kg (16.53 lb)  |
| Mounting                              | <ul style="list-style-type: none"> <li>• Wallmount by mounting bracket</li> <li>• DIN Rail and VESA Mounting (Optional)</li> </ul> |
| <b>Environment</b>                    |  |
| Operating Temperature (with air flow) | -20°C to 45°C (-4°F to 113°F), with System Fan   |
| Storage Temperature                   | -40°C to 85°C (-40°F to 185°F)   |
| Humidity                              | 5% to 95% humidity, non-condensing   |
| Relative Humidity                     | 95% at 45°C  |
| Shock /Vibration                      | Operating, MIL-STD-810G, Procedure I   |
| EMC                                   | CE, FCC, EN50155, EN50121-3-2  |

### 1.3.2 Specifications of ECX-3600 PEG

| <b>System</b>        |   |
|----------------------|---|
| Processor            | <ul style="list-style-type: none"> <li>• 24-core Intel® Core™ i9/i7/i5/i3 Processor (14th gen, Raptor Lake-S Refresh)</li> <li>• 24-core 13th Gen Intel® Core™ i9/i7/i5/i3 Processor (Raptor Lake-S)</li> <li>• 16-core 12th Gen Intel® Core™ i9/i7/i5/i3 Processor (Alder Lake-S)</li> </ul> |
| Chipset              | Intel® R680E  |
| BIOS                 | AMI   |
| SIO                  | IT8786E   |
| Memory               | 2 DDR5 5200MHz SO-DIMM, up to 96GB (ECC/Non-ECC)  |
| <b>I/O Interface</b> |   |
| Serial               | 4 COM RS-232/422/485 (ESD 8KV)  |
| USB                  | <ul style="list-style-type: none"> <li>• 6 USB 3.2 Gen 2, USB Type A Connector</li> <li>• 1 USB 3.2 Gen 2x2, USB Type C Connector supports max 20Gbps data transfer (15W, 5V/3A)</li> </ul>   |
| Isolated DIO         | 32 Isolated DIO : 16 DI, 16 DO  |
| LED                  | Power, HDD, Wireless, PoE   |
| SIM Card             | 3 External Nano SIM Card Sockets  |
| RTC Battery          | 1 Front-access RTC Battery  |
| <b>Expansion</b>     |   |
| Mini PCIe            | 1 Mini PCIe sockets for PCIe/USB/SIM Card   |
| PCI/PCIe             | 4 PCIe Slot : <ul style="list-style-type: none"> <li>• 2 PCIe x16 Slot with x8 signal</li> <li>• 1 PCIe x8 Slot with x4 signal</li> </ul>   |
| M.2                  | <ul style="list-style-type: none"> <li>• 1 M.2 Key B Socket (2280/3042)</li> <li>• 1 M.2 Key B Socket (2280/3052)</li> <li>• 1 M.2 Key E Socket (2230)</li> </ul>   |
| <b>Graphics</b>      |   |
| Graphics Processor   | Intel® UHD Graphics 770/730 driven by Intel® X <sup>e</sup> Architecture  |
| Interface            | <ul style="list-style-type: none"> <li>• 1 DVI-I : Up to 1920 x 1080 @60Hz</li> <li>• 1 HDMI : Up to 1920 x 1080 @60Hz</li> <li>• 2 DisplayPort : Up to 7680 x 4320 @60Hz/5120 x 2880 @120Hz</li> <li>• By requested Graphics Card</li> </ul>   |
| <b>Storage</b>       |   |
| SATA                 | 4 SATA III (6Gbps) support S/W RAID 0, 1, 5, 10   |
| M.2                  | 1 M.2 Key M Socket (2280, PCIe x4)  |
| Storage Device       | 4 Front-access 2.5" SSD/HDD Tray  |
| <b>Audio</b>         |   |
| Audio Codec          | Realtek® ALC888S-VD, 7.1 Channel HD Audio   |
| Audio Interface      | 1 Mic-in, 1 Line-out  |

| <b>Ethernet</b>                       |  |
|---------------------------------------|--|
| LAN 1                                 | Intel® I219LM GigE LAN supports iAMT   |
| LAN 2                                 | Intel® I210 GigE LAN   |
| <b>PoE</b>                            |  |
| LAN 3                                 | 2.5GigE IEEE 802.3at (25.5W/48V) PoE+ by Intel® I226, RJ45 Connector   |
| LAN 4                                 | 2.5GigE IEEE 802.3at (25.5W/48V) PoE+ by Intel® I226, RJ45 Connector   |
| LAN 5                                 | 2.5GigE IEEE 802.3at (25.5W/48V) PoE+ by Intel® I226, RJ45 Connector   |
| LAN 6                                 | 2.5GigE IEEE 802.3at (25.5W/48V) PoE+ by Intel® I226, RJ45 Connector   |
| <b>Power</b>                          |  |
| Input Voltage                         | DC 12V to 50V Power Input  |
| Power Interface                       | 3-pin Terminal Block : V+, V-, Frame Ground  |
| Ignition Control                      | 16 Mode Software Ignition Control  |
| Remote Switch                         | 3-pin Terminal Block : On, Off, IGN  |
| Surge Protection                      | Up to 80V/1ms Transient Power  |
| <b>Others</b>                         |  |
| TPM                                   | Infineon SLB9670 supports TPM 2.0, SPI Interface   |
| Watchdog Timer                        | Reset : 1 to 255 sec./min. per step  |
| Smart Management                      | Wake on LAN, PXE supported   |
| HW Monitor                            | Monitoring temperature, voltages. Auto throttling control when CPU overheats.  |
| <b>Software Support</b>               |  |
| OS                                    | Windows 10, Linux  |
| <b>Mechanical</b>                     |  |
| Dimension (W x D x H)                 | 260mm x 240mm x 120mm (10.24"x9.45"x4.72")   |
| Weight                                | 6.5 kg (14.33 lb)  |
| Mounting                              | <ul style="list-style-type: none"> <li>• Wallmount by mounting bracket</li> <li>• DIN Rail and VESA Mounting (Optional)</li> </ul> |
| <b>Environment</b>                    |  |
| Operating Temperature (with air flow) | -20°C to 45°C (-4°F to 113°F), with System Fan   |
| Storage Temperature                   | -40°C to 85°C (-40°F to 185°F)   |
| Humidity                              | 5% to 95% humidity, non-condensing   |
| Relative Humidity                     | 95% at 45°C  |
| Shock /Vibration                      | Operating, MIL-STD-810G, Procedure I   |
| EMC                                   | CE, FCC, EN50155, EN50121-3-2  |

### 1.3.3 Specifications of ECX-3400 PEG

| <b>System</b>        |   |
|----------------------|---|
| Processor            | <ul style="list-style-type: none"> <li>• 24-core Intel® Core™ i9/i7/i5/i3 Processor (14th gen, Raptor Lake-S Refresh)</li> <li>• 24-core 13th Gen Intel® Core™ i9/i7/i5/i3 Processor (Raptor Lake-S)</li> <li>• 16-core 12th Gen Intel® Core™ i9/i7/i5/i3 Processor (Alder Lake-S)</li> </ul> |
| Chipset              | Intel® R680E  |
| BIOS                 | AMI   |
| SIO                  | IT8786E   |
| Memory               | 2 DDR5 5200MHz SO-DIMM, up to 96GB (ECC/Non-ECC)  |
| <b>I/O Interface</b> |   |
| Serial               | 4 COM RS-232/422/485 (ESD 8KV)  |
| USB                  | <ul style="list-style-type: none"> <li>• 6 USB 3.2 Gen 2, USB Type A Connector</li> <li>• 1 USB 3.2 Gen 2x2, USB Type C Connector supports max 20Gbps data transfer (15W, 5V/3A)</li> </ul>   |
| Isolated DIO         | 32 Isolated DIO : 16 DI, 16 DO  |
| LED                  | Power, HDD, Wireless, PoE   |
| SIM Card             | 3 External Nano SIM Card Sockets  |
| RTC Battery          | 1 Front-access RTC Battery  |
| <b>Expansion</b>     |   |
| Mini PCIe            | 1 Mini PCIe sockets for PCIe/USB/SIM Card   |
| PCI/PCIe             | 2 PCIe Slot : <ul style="list-style-type: none"> <li>• 1 PCIe x16 Slot with x16 signal</li> <li>• 1 PCIe x16 Slot with x4 signal</li> </ul>   |
| M.2                  | <ul style="list-style-type: none"> <li>• 1 M.2 Key B Socket (2280/3042)</li> <li>• 1 M.2 Key B Socket (2280/3052)</li> <li>• 1 M.2 Key E Socket (2230)</li> </ul>   |
| <b>Graphics</b>      |   |
| Graphics Processor   | Intel® UHD Graphics 770/730 driven by Intel® X <sup>e</sup> Architecture  |
| Interface            | <ul style="list-style-type: none"> <li>• 1 DVI-I : Up to 1920 x 1080 @60Hz</li> <li>• 1 HDMI : Up to 1920 x 1080 @60Hz</li> <li>• 2 DisplayPort : Up to 7680 x 4320 @60Hz/5120 x 2880 @120Hz</li> <li>• By requested Graphics Card</li> </ul>   |
| <b>Storage</b>       |   |
| SATA                 | 4 SATA III (6Gbps) support S/W RAID 0, 1, 5, 10   |
| M.2                  | 1 M.2 Key M Socket (2280, PCIe x4)  |
| Storage Device       | 4 Front-access 2.5" SSD/HDD Tray  |
| <b>Audio</b>         |   |
| Audio Codec          | Realtek® ALC888S-VD, 7.1 Channel HD Audio   |
| Audio Interface      | 1 Mic-in, 1 Line-out  |

| <b>Ethernet</b>                       |  |
|---------------------------------------|--|
| LAN 1                                 | Intel® I219LM GigE LAN supports iAMT   |
| LAN 2                                 | Intel® I210 GigE LAN   |
| <b>PoE</b>                            |  |
| LAN 3                                 | 2.5GigE IEEE 802.3at (25.5W/48V) PoE+ by Intel® I226, RJ45 Connector   |
| LAN 4                                 | 2.5GigE IEEE 802.3at (25.5W/48V) PoE+ by Intel® I226, RJ45 Connector   |
| LAN 5                                 | 2.5GigE IEEE 802.3at (25.5W/48V) PoE+ by Intel® I226, RJ45 Connector   |
| LAN 6                                 | 2.5GigE IEEE 802.3at (25.5W/48V) PoE+ by Intel® I226, RJ45 Connector   |
| <b>Power</b>                          |  |
| Input Voltage                         | DC 12V to 50V Power Input  |
| Power Interface                       | 3-pin Terminal Block : V+, V-, Frame Ground  |
| Ignition Control                      | 16 Mode Software Ignition Control  |
| Remote Switch                         | 3-pin Terminal Block : On, Off, IGN  |
| Surge Protection                      | Up to 80V/1ms Transient Power  |
| <b>Others</b>                         |  |
| TPM                                   | Infineon SLB9670 supports TPM 2.0, SPI Interface   |
| Watchdog Timer                        | Reset : 1 to 255 sec./min. per step  |
| Smart Management                      | Wake on LAN, PXE supported   |
| HW Monitor                            | Monitoring temperature, voltages. Auto throttling control when CPU overheats.  |
| <b>Software Support</b>               |  |
| OS                                    | Windows 10, Linux  |
| <b>Mechanical</b>                     |  |
| Dimension (W x D x H)                 | 260mm x 240mm x 104mm (10.24"x9.45"x4.09")   |
| Weight                                | 5.5 kg (12.13 lb)  |
| Mounting                              | <ul style="list-style-type: none"> <li>• Wallmount by mounting bracket</li> <li>• DIN Rail and VESA Mounting (Optional)</li> </ul> |
| <b>Environment</b>                    |  |
| Operating Temperature (with air flow) | -20°C to 45°C (-4°F to 113°F), with System Fan   |
| Storage Temperature                   | -40°C to 85°C (-40°F to 185°F)   |
| Humidity                              | 5% to 95% humidity, non-condensing   |
| Relative Humidity                     | 95% at 45°C  |
| Shock /Vibration                      | Operating, MIL-STD-810G, Procedure I   |
| EMC                                   | CE, FCC, EN50155, EN50121-3-2  |



### 1.3.4 Specifications of ECX-3200MX PEG

| <b>System</b>        |   |
|----------------------|---|
| Processor            | <ul style="list-style-type: none"> <li>• 24-core Intel® Core™ i9/i7/i5/i3 Processor (14th gen, Raptor Lake-S Refresh)</li> <li>• 24-core 13th Gen Intel® Core™ i9/i7/i5/i3 Processor (Raptor Lake-S)</li> <li>• 16-core 12th Gen Intel® Core™ i9/i7/i5/i3 Processor (Alder Lake-S)</li> </ul> |
| Chipset              | Intel® R680E  |
| BIOS                 | AMI   |
| SIO                  | IT8786E   |
| Memory               | 2 DDR5 5200MHz SO-DIMM, up to 96GB (ECC/Non-ECC)  |
| <b>I/O Interface</b> |   |
| Serial               | 4 COM RS-232/422/485 (ESD 8KV)  |
| USB                  | <ul style="list-style-type: none"> <li>• 6 USB 3.2 Gen 2, USB Type A Connector</li> <li>• 1 USB 3.2 Gen 2x2, USB Type C Connector supports max 20Gbps data transfer (15W, 5V/3A)</li> </ul>   |
| Isolated DIO         | 32 Isolated DIO : 16 DI, 16 DO  |
| LED                  | Power, HDD, Wireless, PoE   |
| SIM Card             | 3 External Nano SIM Card Sockets  |
| RTC Battery          | 1 Front-access RTC Battery  |
| <b>Expansion</b>     |   |
| Mini PCIe            | 1 Mini PCIe sockets for PCIe/USB/SIM Card   |
| PCI/PCIe             | 1 PCIe x16 Slot   |
| M.2                  | <ul style="list-style-type: none"> <li>• 1 M.2 Key B Socket (2280/3042)</li> <li>• 1 M.2 Key B Socket (2280/3052)</li> <li>• 1 M.2 Key E Socket (2230)</li> </ul>   |
| <b>Graphics</b>      |   |
| Graphics Processor   | Intel® UHD Graphics 770/730 driven by Intel® X <sup>e</sup> Architecture  |
| Interface            | <ul style="list-style-type: none"> <li>• 1 DVI-I : Up to 1920 x 1080 @60Hz</li> <li>• 1 HDMI : Up to 1920 x 1080 @60Hz</li> <li>• 2 DisplayPort : Up to 7680 x 4320 @60Hz/5120 x 2880 @120Hz</li> <li>• By requested Graphics Card</li> </ul>   |
| <b>Storage</b>       |   |
| SATA                 | 2 SATA III (6Gbps) support S/W RAID 0, 1  |
| M.2                  | 1 M.2 Key M Socket (2280, PCIe x4)  |
| Storage Device       | 2 Front-access 2.5" SSD/HDD Tray  |
| <b>Audio</b>         |   |
| Audio Codec          | Realtek® ALC888S-VD, 7.1 Channel HD Audio   |
| Audio Interface      | 1 Mic-in, 1 Line-out  |

| <b>Ethernet</b>                       |   |
|---------------------------------------|---|
| LAN 1                                 | Intel® I219LM GigE LAN supports iAMT  |
| LAN 2                                 | Intel® I210 GigE LAN  |
| <b>PoE</b>                            |   |
| LAN 3                                 | 2.5GigE IEEE 802.3at (25.5W/48V) PoE+ by Intel® I226, M12 Connector   |
| LAN 4                                 | 2.5GigE IEEE 802.3at (25.5W/48V) PoE+ by Intel® I226, M12 Connector   |
| LAN 5                                 | 2.5GigE IEEE 802.3at (25.5W/48V) PoE+ by Intel® I226, M12 Connector   |
| LAN 6                                 | 2.5GigE IEEE 802.3at (25.5W/48V) PoE+ by Intel® I226, M12 Connector   |
| <b>Power</b>                          |   |
| Input Voltage                         | DC 12V to 50V Power Input   |
| Power Interface                       | 3-pin Terminal Block : V+, V-, Frame Ground   |
| Ignition Control                      | 16 Mode Software Ignition Control   |
| Remote Switch                         | 3-pin Terminal Block : On, Off, IGN   |
| Surge Protection                      | Up to 80V/1ms Transient Power   |
| <b>Others</b>                         |   |
| TPM                                   | Infineon SLB9670 supports TPM 2.0, SPI Interface  |
| Watchdog Timer                        | Reset : 1 to 255 sec./min. per step   |
| Smart Management                      | Wake on LAN, PXE supported  |
| HW Monitor                            | Monitoring temperature, voltages. Auto throttling control when CPU overheats.   |
| <b>Software Support</b>               |   |
| OS                                    | Windows 10, Linux   |
| <b>Mechanical</b>                     |   |
| Dimension (W x D x H)                 | 260mm x 240mm x 79mm (10.24"x9.45"x3.11")   |
| Weight                                | 4.5 kg (9.92 lb)  |
| Mounting                              | <ul style="list-style-type: none"> <li>• Wallmount by mounting bracket</li> <li>• DIN Rail and VESA Mounting (Optional)</li> <li>• 2U Rackmount (Optional)</li> </ul> |
| <b>Environment</b>                    |   |
| Operating Temperature (with air flow) | -20°C to 45°C (-4°F to 113°F), with System Fan  |
| Storage Temperature                   | -40°C to 85°C (-40°F to 185°F)  |
| Humidity                              | 5% to 95% humidity, non-condensing  |
| Relative Humidity                     | 95% at 45°C   |
| Shock /Vibration                      | Operating, MIL-STD-810G, Procedure I  |
| EMC                                   | CE, FCC, EN50155, EN50121-3-2   |

### 1.3.5 Specifications of ECX-3200 PEG

| <b>System</b>        |   |
|----------------------|---|
| Processor            | <ul style="list-style-type: none"> <li>• 24-core Intel® Core™ i9/i7/i5/i3 Processor (14th gen, Raptor Lake-S Refresh)</li> <li>• 24-core 13th Gen Intel® Core™ i9/i7/i5/i3 Processor (Raptor Lake-S)</li> <li>• 16-core 12th Gen Intel® Core™ i9/i7/i5/i3 Processor (Alder Lake-S)</li> </ul> |
| Chipset              | Intel® R680E  |
| BIOS                 | AMI   |
| SIO                  | IT8786E   |
| Memory               | 2 DDR5 5200MHz SO-DIMM, up to 96GB (ECC/Non-ECC)  |
| <b>I/O Interface</b> |   |
| Serial               | 4 COM RS-232/422/485 (ESD 8KV)  |
| USB                  | <ul style="list-style-type: none"> <li>• 6 USB 3.2 Gen 2, USB Type A Connector</li> <li>• 1 USB 3.2 Gen 2x2, USB Type C Connector supports max 20Gbps data transfer (15W, 5V/3A)</li> </ul>   |
| Isolated DIO         | 32 Isolated DIO : 16 DI, 16 DO  |
| LED                  | Power, HDD, Wireless, PoE   |
| SIM Card             | 3 External Nano SIM Card Sockets  |
| RTC Battery          | 1 Front-access RTC Battery  |
| <b>Expansion</b>     |   |
| Mini PCIe            | 1 Mini PCIe sockets for PCIe/USB/SIM Card   |
| PCI/PCIe             | 1 PCIe x16 Slot   |
| M.2                  | <ul style="list-style-type: none"> <li>• 1 M.2 Key B Socket (2280/3042)</li> <li>• 1 M.2 Key B Socket (2280/3052)</li> <li>• 1 M.2 Key E Socket (2230)</li> </ul>   |
| <b>Graphics</b>      |   |
| Graphics Processor   | Intel® UHD Graphics 770/730 driven by Intel® X <sup>e</sup> Architecture  |
| Interface            | <ul style="list-style-type: none"> <li>• 1 DVI-I : Up to 1920 x 1080 @60Hz</li> <li>• 1 HDMI : Up to 1920 x 1080 @60Hz</li> <li>• 2 DisplayPort : Up to 7680 x 4320 @60Hz/5120 x 2880 @120Hz</li> <li>• By requested Graphics Card</li> </ul>   |
| <b>Storage</b>       |   |
| SATA                 | 2 SATA III (6Gbps) support S/W RAID 0, 1  |
| M.2                  | 1 M.2 Key M Socket (2280, PCIe x4)  |
| Storage Device       | 2 Front-access 2.5" SSD/HDD Tray  |
| <b>Audio</b>         |   |
| Audio Codec          | Realtek® ALC888S-VD, 7.1 Channel HD Audio   |
| Audio Interface      | 1 Mic-in, 1 Line-out  |

| <b>Ethernet</b>                       |   |
|---------------------------------------|---|
| LAN 1                                 | Intel® I219LM GigE LAN supports iAMT  |
| LAN 2                                 | Intel® I210 GigE LAN  |
| <b>PoE</b>                            |   |
| LAN 3                                 | 2.5GigE IEEE 802.3at (25.5W/48V) PoE+ by Intel® I226, RJ45 Connector  |
| LAN 4                                 | 2.5GigE IEEE 802.3at (25.5W/48V) PoE+ by Intel® I226, RJ45 Connector  |
| LAN 5                                 | 2.5GigE IEEE 802.3at (25.5W/48V) PoE+ by Intel® I226, RJ45 Connector  |
| LAN 6                                 | 2.5GigE IEEE 802.3at (25.5W/48V) PoE+ by Intel® I226, RJ45 Connector  |
| <b>Power</b>                          |   |
| Input Voltage                         | DC 12V to 50V Power Input   |
| Power Interface                       | 3-pin Terminal Block : V+, V-, Frame Ground   |
| Ignition Control                      | 16 Mode Software Ignition Control   |
| Remote Switch                         | 3-pin Terminal Block : On, Off, IGN   |
| Surge Protection                      | Up to 80V/1ms Transient Power   |
| <b>Others</b>                         |   |
| TPM                                   | Infineon SLB9670 supports TPM 2.0, SPI Interface  |
| Watchdog Timer                        | Reset : 1 to 255 sec./min. per step   |
| Smart Management                      | Wake on LAN, PXE supported  |
| HW Monitor                            | Monitoring temperature, voltages. Auto throttling control when CPU overheats.   |
| <b>Software Support</b>               |   |
| OS                                    | Windows 10, Linux   |
| <b>Mechanical</b>                     |   |
| Dimension (W x D x H)                 | 260mm x 240mm x 79mm (10.24"x9.45"x3.11")   |
| Weight                                | 4.5 kg (9.92 lb)  |
| Mounting                              | <ul style="list-style-type: none"> <li>• Wallmount by mounting bracket</li> <li>• DIN Rail and VESA Mounting (Optional)</li> <li>• 2U Rackmount (Optional)</li> </ul> |
| <b>Environment</b>                    |   |
| Operating Temperature (with air flow) | -20°C to 45°C (-4°F to 113°F), with System Fan  |
| Storage Temperature                   | -40°C to 85°C (-40°F to 185°F)  |
| Humidity                              | 5% to 95% humidity, non-condensing  |
| Relative Humidity                     | 95% at 45°C   |
| Shock /Vibration                      | Operating, MIL-STD-810G, Procedure I  |
| EMC                                   | CE, FCC, EN50155, EN50121-3-2   |

### 1.3.6 Specifications of ECX-3100 PEG

| <b>System</b>        |   |
|----------------------|---|
| Processor            | <ul style="list-style-type: none"> <li>• 24-core Intel® Core™ i9/i7/i5/i3 Processor (14th gen, Raptor Lake-S Refresh)</li> <li>• 24-core 13th Gen Intel® Core™ i9/i7/i5/i3 Processor (Raptor Lake-S)</li> <li>• 16-core 12th Gen Intel® Core™ i9/i7/i5/i3 Processor (Alder Lake-S)</li> </ul> |
| Chipset              | Intel® R680E  |
| BIOS                 | AMI   |
| SIO                  | IT8786E   |
| Memory               | 2 DDR5 5200MHz SO-DIMM, up to 96GB (ECC/Non-ECC)  |
| <b>I/O Interface</b> |   |
| Serial               | 4 COM RS-232/422/485 (ESD 8KV)  |
| USB                  | <ul style="list-style-type: none"> <li>• 6 USB 3.2 Gen 2, USB Type A Connector</li> <li>• 1 USB 3.2 Gen 2x2, USB Type C Connector supports max 20Gbps data transfer (15W, 5V/3A)</li> </ul>   |
| Isolated DIO         | 16 GPIO   |
| LED                  | Power, HDD, Wireless, PoE   |
| SIM Card             | 3 External Nano SIM Card Sockets  |
| RTC Battery          | 1 Front-access RTC Battery  |
| <b>Expansion</b>     |   |
| Mini PCIe            | 1 Mini PCIe sockets for PCIe/USB/SIM Card   |
| PCI/PCIe             | 1 PCIe x16 Slot   |
| M.2                  | <ul style="list-style-type: none"> <li>• 1 M.2 Key B Socket (2280/3042)</li> <li>• 1 M.2 Key B Socket (2280/3052)</li> <li>• 1 M.2 Key E Socket (2230)</li> </ul>   |
| <b>Graphics</b>      |   |
| Graphics Processor   | Intel® UHD Graphics 770/730 driven by Intel® X <sup>e</sup> Architecture  |
| Interface            | <ul style="list-style-type: none"> <li>• 1 DVI-I : Up to 1920 x 1080 @60Hz</li> <li>• 1 HDMI : Up to 1920 x 1080 @60Hz</li> <li>• 2 DisplayPort : Up to 7680 x 4320 @60Hz/5120 x 2880 @120Hz</li> <li>• By requested Graphics Card</li> </ul>   |
| <b>Storage</b>       |   |
| SATA                 | 2 SATA III (6Gbps) support S/W RAID 0, 1  |
| M.2                  | 1 M.2 Key M Socket (2280, PCIe x4)  |
| Storage Device       | 2 Front-access 2.5" SSD/HDD Tray  |
| <b>Audio</b>         |   |
| Audio Codec          | Realtek® ALC888S-VD, 7.1 Channel HD Audio   |
| Audio Interface      | 1 Mic-in, 1 Line-out  |

| <b>Ethernet</b>                       |   |
|---------------------------------------|---|
| LAN 1                                 | Intel® I219LM GigE LAN supports iAMT  |
| LAN 2                                 | Intel® I210 GigE LAN  |
| <b>Power</b>                          |   |
| Input Voltage                         | DC 12V to 50V Power Input   |
| Power Interface                       | 3-pin Terminal Block : V+, V-, Frame Ground   |
| Ignition Control                      | 16 Mode Software Ignition Control   |
| Remote Switch                         | 3-pin Terminal Block : On, Off, IGN   |
| Surge Protection                      | Up to 80V/1ms Transient Power   |
| <b>Others</b>                         |   |
| TPM                                   | Infineon SLB9670 supports TPM 2.0, SPI Interface  |
| Watchdog Timer                        | Reset : 1 to 255 sec./min. per step   |
| Smart Management                      | Wake on LAN, PXE supported  |
| HW Monitor                            | Monitoring temperature, voltages. Auto throttling control when CPU overheats.   |
| <b>Software Support</b>               |   |
| OS                                    | Windows 10, Linux   |
| <b>Mechanical</b>                     |   |
| Dimension (W x D x H)                 | 260mm x 240mm x 79mm (10.24"x9.45"x3.11")   |
| Weight                                | 4.5 kg (9.92 lb)  |
| Mounting                              | <ul style="list-style-type: none"> <li>• Wallmount by mounting bracket</li> <li>• DIN Rail and VESA Mounting (Optional)</li> <li>• 2U Rackmount (Optional)</li> </ul> |
| <b>Environment</b>                    |   |
| Operating Temperature (with air flow) | -20°C to 45°C (-4°F to 113°F), with System Fan  |
| Storage Temperature                   | -40°C to 85°C (-40°F to 185°F)  |
| Humidity                              | 5% to 95% humidity, non-condensing  |
| Relative Humidity                     | 95% at 45°C   |
| Shock /Vibration                      | Operating, MIL-STD-810G, Procedure I  |
| EMC                                   | CE, FCC, EN50155, EN50121-3-2   |

## 1.4 Supported CPU List

| Series                   | CPU        | Cores | GHz | TDP (W) | ECC |
|--------------------------|------------|-------|-----|---------|-----|
| Intel® Core™ (14th Gen)* | i9-14900   | 24    | 5.8 | 65      | Y   |
|                          | i7-14700   | 20    | 5.4 |         |     |
|                          | i5-14500   | 14    | 5   |         |     |
|                          | i3-14100   | 4     | 4.7 |         |     |
|                          | i9-14900T  | 24    | 5.5 | 35      |     |
|                          | i7-14700T  | 20    | 5.2 |         |     |
|                          | i5-14500T  | 14    | 4.8 |         |     |
|                          | i3-14100T  | 4     | 4.4 |         |     |
| Intel® Core™ (13th Gen)  | i9-13900E  | 24    | 5.2 | 65      |     |
|                          | i7-13700E  | 16    | 5.1 |         |     |
|                          | i5-13500E  | 14    | 4.6 |         |     |
|                          | i3-13100E  | 4     | 4.4 |         |     |
|                          | i9-13900TE | 24    | 5   | 35      |     |
|                          | i7-13700TE | 16    | 4.8 |         |     |
|                          | i5-13500TE | 14    | 4.5 |         |     |
|                          | i3-13100TE | 4     | 4.1 |         |     |
| Intel® Core™ (12th Gen)  | i9-12900E  | 16    | 5   | 65      |     |
|                          | i7-12700E  | 12    | 4.8 |         |     |
|                          | i5-12500E  | 6     | 4.5 |         |     |
|                          | i3-12100E  | 4     | 4.2 |         |     |
|                          | i9-12900TE | 16    | 4.8 | 35      |     |
|                          | i7-12700TE | 12    | 4.7 |         |     |
|                          | i5-12500TE | 6     | 4.3 |         |     |
|                          | i3-12100TE | 4     | 4   |         |     |

\* 14th Gen support PC Client use condition only.

# 1.5 Mechanical Dimension

## 1.5.1 Dimensions of ECX-3800 PEG

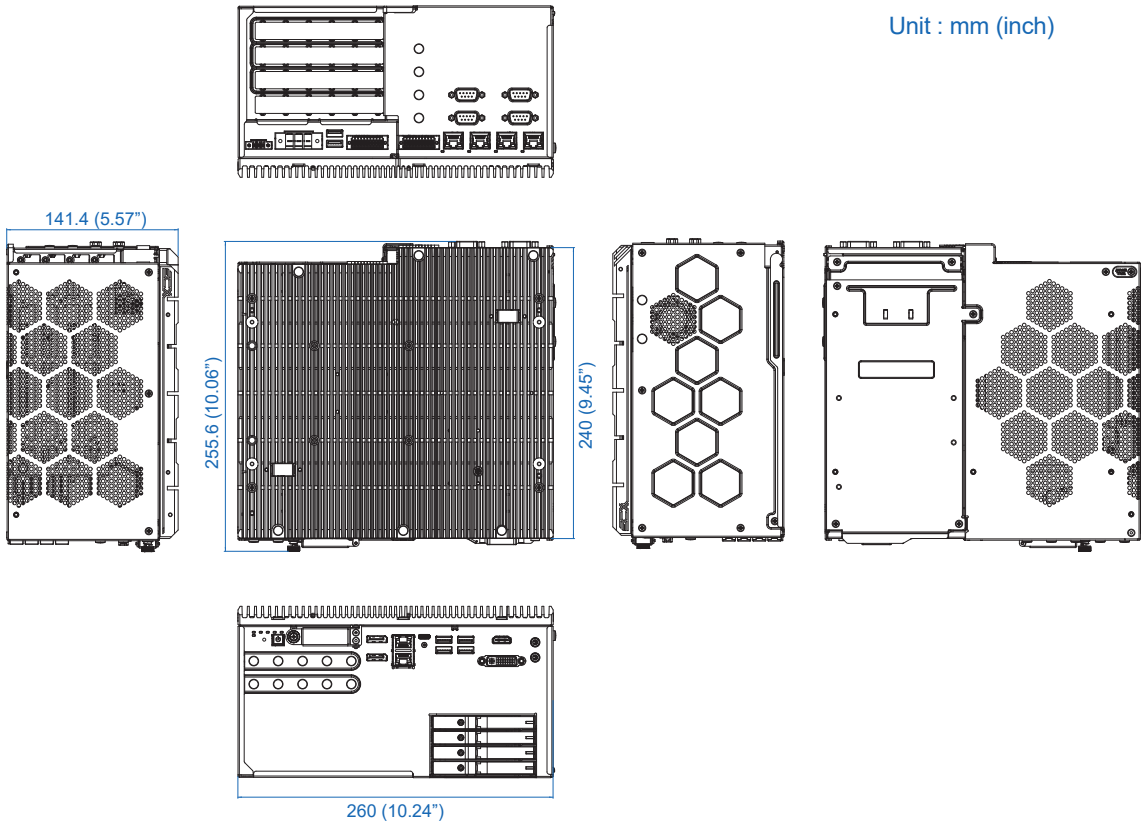

## 1.5.2 Dimensions of ECX-3600 PEG

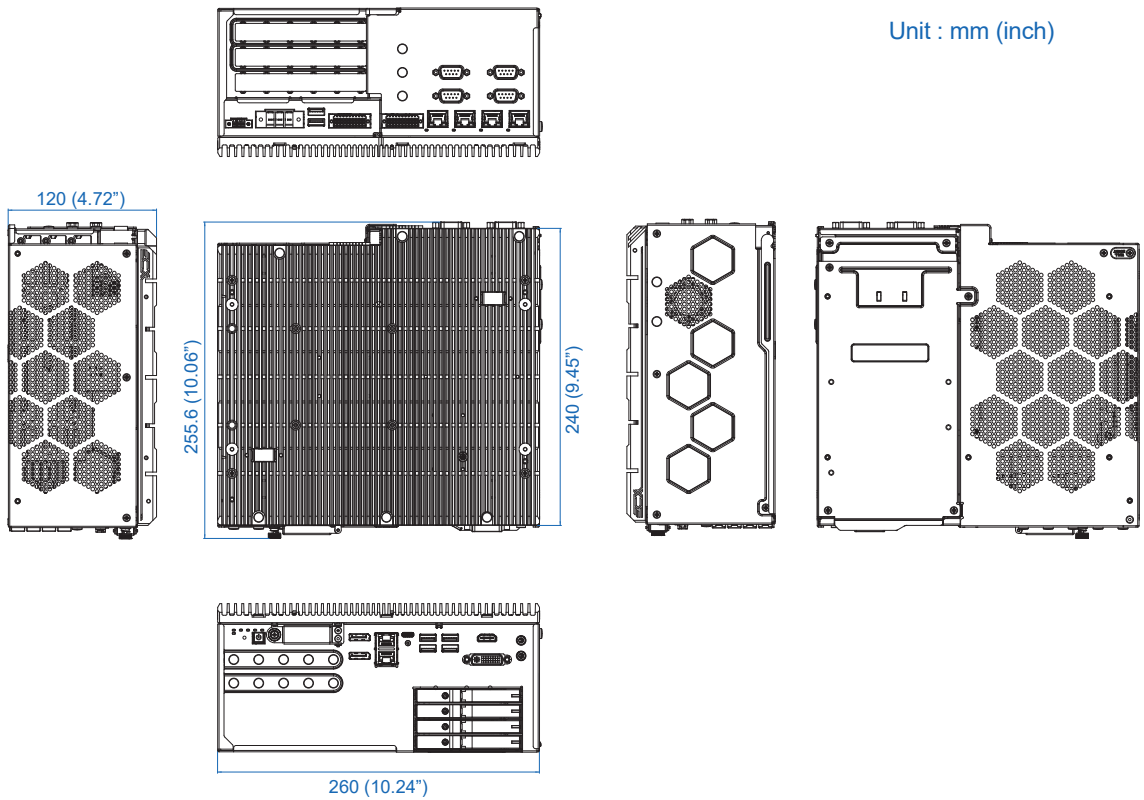



### 1.5.3 Dimensions of ECX-3400 PEG

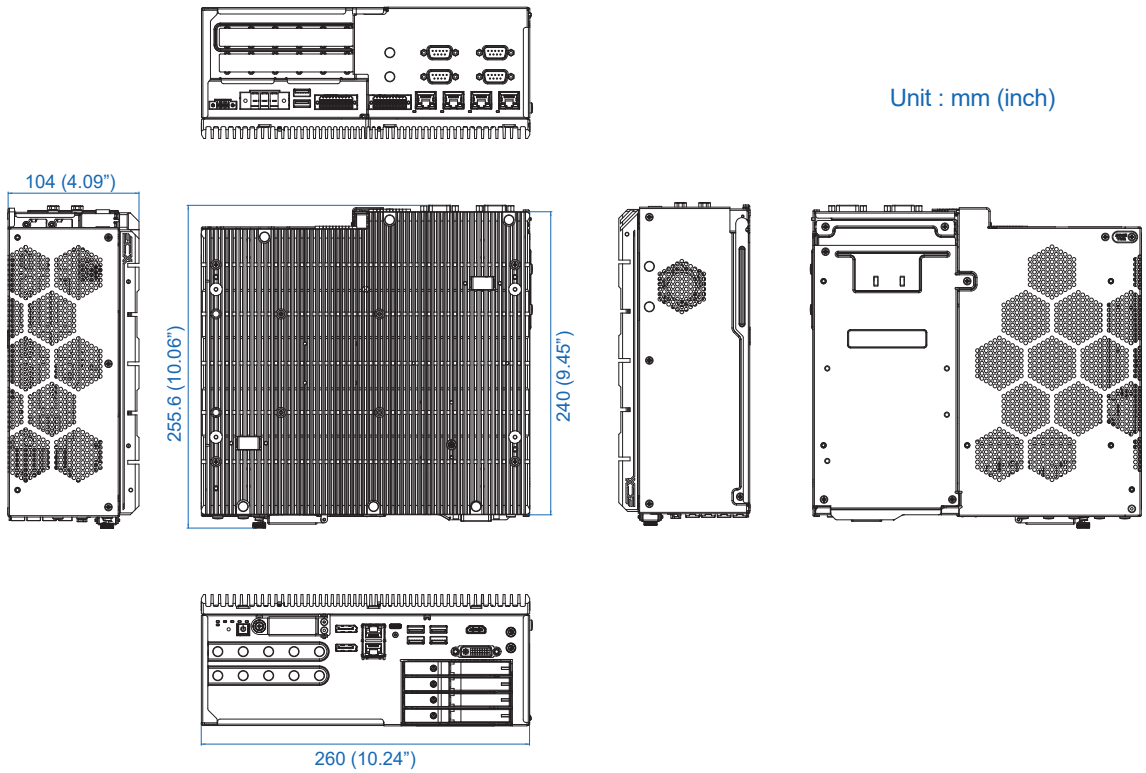

### 1.5.4 Dimensions of ECX-3200MX PEG

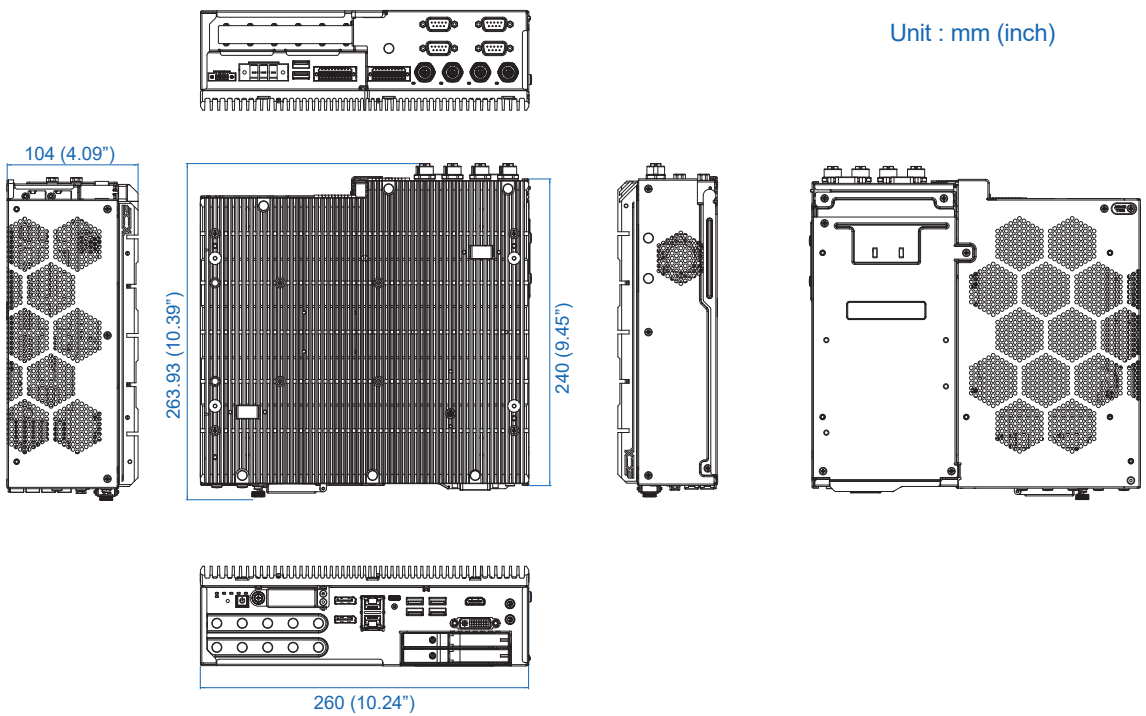

### 1.5.5 Dimensions of ECX-3200 PEG

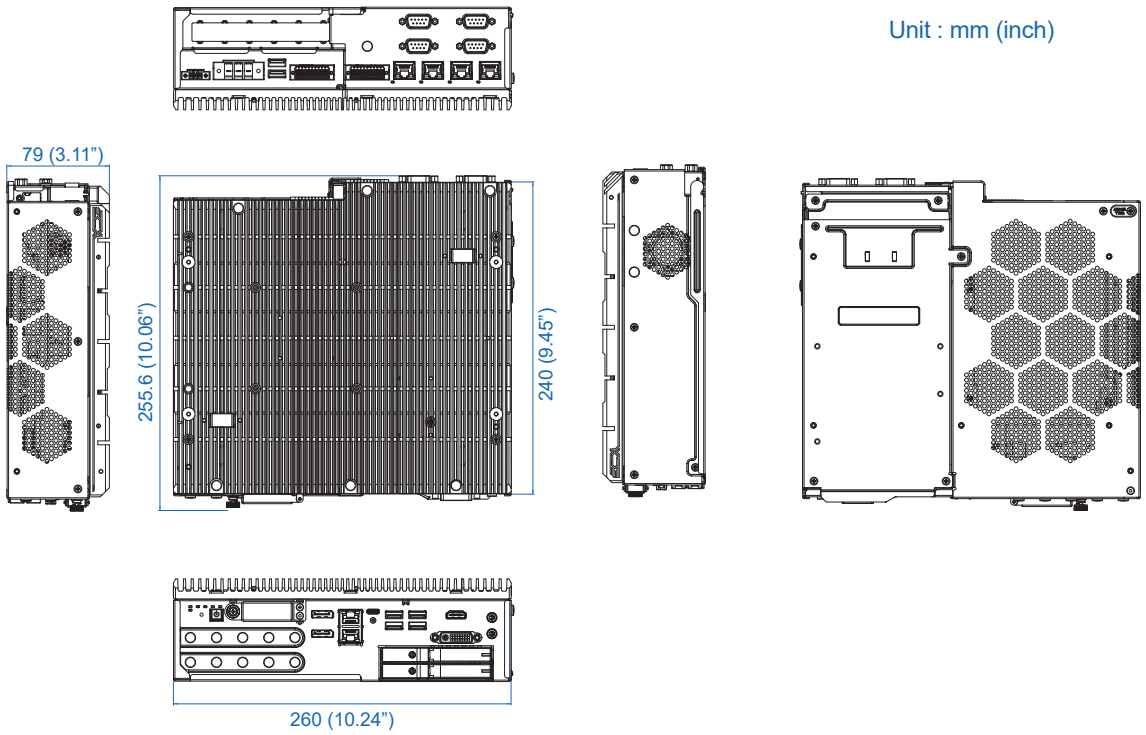

### 1.5.6 Dimensions of ECX-3100 PEG

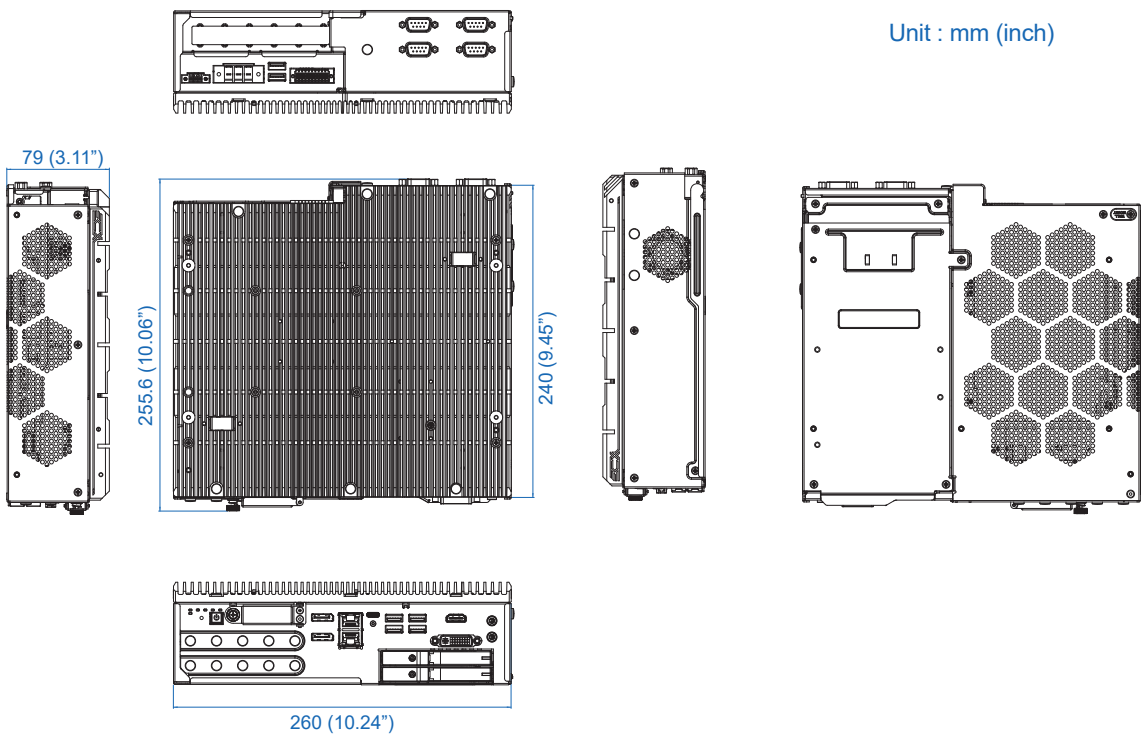

# 2

## GETTING TO KNOW YOUR ECX-3000 PEG

### 2.1 Packing List

#### 2.1.1 ECX-3800 PEG Packing List

| Item | Description  | Qty |
|------|--|-----|
| 1    | ECX-3800 PEG AI Computing System<br>(According to the configuration of you order, the ECX-3000 PEG series may contain SSD/HDD and DDR5 SO-DIMM. Please verify these items if necessary.) | 1   |

| Item | Description                    | Outlook   | Usage                 | P/N            | Qty |
|------|--------------------------------|---|-----------------------|----------------|-----|
| 1    | P head_ M2.5x6L_Ni             |  | Mini PCIe module card | 53-M009310-000 | 1   |
| 2    | I head_ M3x4L_Ni_Nylok         |  | M.2 module card       | 53-M006400-010 | 4   |
| 3    | Hex. standoff_ M3x11.5L_Nylok  |  | Wall mount bracket    | 53-M006281-214 | 4   |
| 4    | Flat head_ M3x5L_Black_Nylok   |  | Wall mount bracket    | 53-M004950-310 | 6   |
| 5    | Terminal block 3-pin (7.62mm)  |  | DC-IN                 | 51-2611R03-S1N | 1   |
| 6    | Terminal block 3-pin (3.5mm)   |  | Switch                | 51-2211R03-S1A | 1   |
| 7    | Terminal block 20-pin (2.54mm) |  | Isolated DIO/ GPIO    | 51-2112R20-S1D | 2   |
| 8    | Bracket_Wall Mount             |  | Wall Mount            | 62-03P1100-20B | 2   |
| 9    | Key                            |  | SSD/HDD tray          | N/A            | 4   |

## 2.1.2 ECX-3600 PEG Packing List

| Item | Description  | Qty |
|------|--|-----|
| 1    | ECX-3600 PEG AI Computing System<br>(According to the configuration of you order, the ECX-3000 PEG series may contain SSD/HDD and DDR5 SO-DIMM. Please verify these items if necessary.) | 1   |

| Item | Description                    | Outlook   | Usage                 | P/N            | Qty |
|------|--------------------------------|---|-----------------------|----------------|-----|
| 1    | P head_ M2.5x6L_Ni             |    | Mini PCIe module card | 53-M009310-000 | 1   |
| 2    | I head_ M3x4L_Ni_Nylok         |    | M.2 module card       | 53-M006400-010 | 4   |
| 3    | Hex. standoff_ M3x11.5L_Nylok  |    | Wall mount bracket    | 53-M006281-214 | 4   |
| 4    | Flat head_ M3x5L_Black_Nylok   |   | Wall mount bracket    | 53-M004950-310 | 6   |
| 5    | Terminal block 3-pin (7.62mm)  |  | DC-IN                 | 51-2611R03-S1N | 1   |
| 6    | Terminal block 3-pin (3.5mm)   |  | Switch                | 51-2211R03-S1A | 1   |
| 7    | Terminal block 20-pin (2.54mm) |  | Isolated DIO/ GPIO    | 51-2112R20-S1D | 2   |
| 8    | Bracket_Wall Mount             |  | Wall Mount            | 62-03P1100-20B | 2   |
| 9    | Key                            |  | SSD/HDD tray          | N/A            | 4   |

### 2.1.3 ECX-3400 PEG Packing List

| Item | Description  | Qty |
|------|--|-----|
| 1    | ECX-3400 PEG AI Computing System<br>(According to the configuration of you order, the ECX-3000 PEG series may contain SSD/HDD and DDR5 SO-DIMM. Please verify these items if necessary.) | 1   |

| Item | Description                    | Outlook   | Usage                 | P/N            | Qty |
|------|--------------------------------|---|-----------------------|----------------|-----|
| 1    | P head_ M2.5x6L_Ni             |    | Mini PCIe module card | 53-M009310-000 | 1   |
| 2    | I head_ M3x4L_Ni_Nylok         |    | M.2 module card       | 53-M006400-010 | 4   |
| 3    | Hex. standoff_ M3x11.5L_Nylok  |    | Wall mount bracket    | 53-M006281-214 | 4   |
| 4    | Flat head_ M3x5L_Black_Nylok   |   | Wall mount bracket    | 53-M004950-310 | 6   |
| 5    | Terminal block 3-pin (7.62mm)  |  | DC-IN                 | 51-2611R03-S1N | 1   |
| 6    | Terminal block 3-pin (3.5mm)   |  | Switch                | 51-2211R03-S1A | 1   |
| 7    | Terminal block 20-pin (2.54mm) |  | Isolated DIO/ GPIO    | 51-2112R20-S1D | 2   |
| 8    | Bracket_Wall Mount             |  | Wall Mount            | 62-03P1100-20B | 2   |
| 9    | Key                            |  | SSD/HDD tray          | N/A            | 4   |

## 2.1.4 ECX-3200MX PEG Packing List

| Item | Description  | Qty |
|------|--|-----|
| 1    | ECX-3200MX PEG AI Computing System<br>(According to the configuration of you order, the ECX-3000MX PEG series may contain SSD/HDD and DDR5 SO-DIMM. Please verify these items if necessary.) | 1   |

| Item | Description                          | Outlook   | Usage                    | P/N            | Qty |
|------|--------------------------------------|---|--------------------------|----------------|-----|
| 1    | P head_<br>M2.5x6L_Ni                |    | Mini PCIe<br>module card | 53-M009310-000 | 1   |
| 2    | I head_ M3x4L_<br>Ni_Nylok           |    | M.2 module<br>card       | 53-M006400-010 | 4   |
| 3    | Hex. standoff_<br>M3x11.5L_<br>Nylok |    | Wall mount<br>bracket    | 53-M006281-214 | 4   |
| 4    | Flat head_<br>M3x5L_<br>Black_Nylok  |   | Wall mount<br>bracket    | 53-M004950-310 | 6   |
| 5    | Terminal block<br>3-pin (7.62mm)     |  | DC-IN                    | 51-2611R03-S1N | 1   |
| 6    | Terminal block<br>3-pin (3.5mm)      |  | Switch                   | 51-2211R03-S1A | 1   |
| 7    | Terminal<br>block 20-pin<br>(2.54mm) |  | Isolated DIO/<br>GPIO    | 51-2112R20-S1D | 2   |
| 8    | Bracket_Wall<br>Mount                |  | Wall Mount               | 62-03P1100-20B | 2   |
| 9    | Key                                  |  | SSD/HDD<br>tray          | N/A            | 2   |

## 2.1.5 ECX-3200 PEG Packing List

| Item | Description  | Qty |
|------|--|-----|
| 1    | ECX-3200 PEG AI Computing System<br>(According to the configuration of you order, the ECX-3000 PEG series may contain SSD/HDD and DDR5 SO-DIMM. Please verify these items if necessary.) | 1   |

| Item | Description                          | Outlook   | Usage                    | P/N            | Qty |
|------|--------------------------------------|---|--------------------------|----------------|-----|
| 1    | P head_<br>M2.5x6L_Ni                |    | Mini PCIe<br>module card | 53-M009310-000 | 1   |
| 2    | I head_ M3x4L_<br>Ni_Nylok           |    | M.2 module<br>card       | 53-M006400-010 | 4   |
| 3    | Hex. standoff_<br>M3x11.5L_<br>Nylok |    | Wall mount<br>bracket    | 53-M006281-214 | 4   |
| 4    | Flat head_<br>M3x5L_<br>Black_Nylok  |   | Wall mount<br>bracket    | 53-M004950-310 | 6   |
| 5    | Terminal block<br>3-pin (7.62mm)     |  | DC-IN                    | 51-2611R03-S1N | 1   |
| 6    | Terminal block<br>3-pin (3.5mm)      |  | Switch                   | 51-2211R03-S1A | 1   |
| 7    | Terminal<br>block 20-pin<br>(2.54mm) |  | Isolated DIO/<br>GPIO    | 51-2112R20-S1D | 2   |
| 8    | Bracket_Wall<br>Mount                |  | Wall Mount               | 62-03P1100-20B | 2   |
| 9    | Key                                  |  | SSD/HDD<br>tray          | N/A            | 2   |

## 2.1.6 ECX-3100 PEG Packing List

| Item | Description  | Qty |
|------|--|-----|
| 1    | ECX-3100 PEG AI Computing System<br>(According to the configuration of you order, the ECX-3000 PEG series may contain SSD/HDD and DDR5 SO-DIMM. Please verify these items if necessary.) | 1   |

| Item | Description                          | Outlook   | Usage                    | P/N            | Qty |
|------|--------------------------------------|---|--------------------------|----------------|-----|
| 1    | P head_<br>M2.5x6L_Ni                |    | Mini PCIe<br>module card | 53-M009310-000 | 1   |
| 2    | I head_ M3x4L_<br>Ni_Nylok           |    | M.2 module<br>card       | 53-M006400-010 | 4   |
| 3    | Hex. standoff_<br>M3x11.5L_<br>Nylok |    | Wall mount<br>bracket    | 53-M006281-214 | 4   |
| 4    | Flat head_<br>M3x5L_<br>Black_Nylok  |   | Wall mount<br>bracket    | 53-M004950-310 | 6   |
| 5    | Terminal block<br>3-pin (7.62mm)     |  | DC-IN                    | 51-2611R03-S1N | 1   |
| 6    | Terminal block<br>3-pin (3.5mm)      |  | Switch                   | 51-2211R03-S1A | 1   |
| 7    | Terminal<br>block 20-pin<br>(2.54mm) |  | Isolated DIO/<br>GPIO    | 51-2112R20-S1D | 1   |
| 8    | Bracket_Wall<br>Mount                |  | Wall Mount               | 62-03P1100-20B | 2   |
| 9    | Key                                  |  | SSD/HDD<br>tray          | N/A            | 2   |



## 2.2 Front Panel I/O Functions

In Vecow ECX-3000 PEG series family, all I/O connectors are located on front panel and rear panel. Most of the general connections to computer device, such as USB, LAN Jack, USB TYPE-C, HDMI, DVI-I, Display Port and any additional storage, are placed on the front panel.

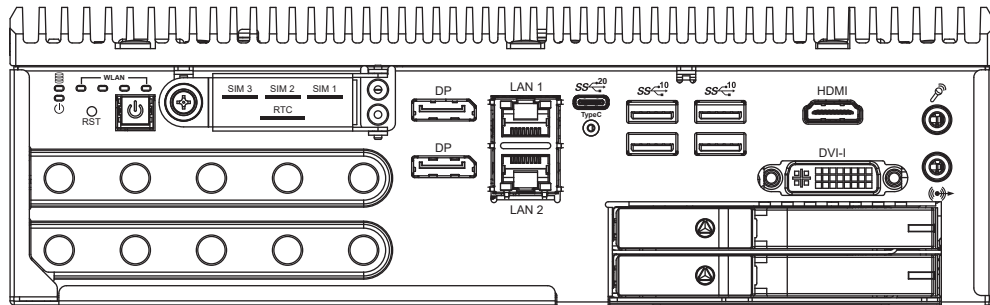

It is a hardware reset switch. Use this switch to reset the system without power off the system. Press the Reset Switch for a few seconds, then reset will be enabled.

### 2.2.1 Reset Tact Switch

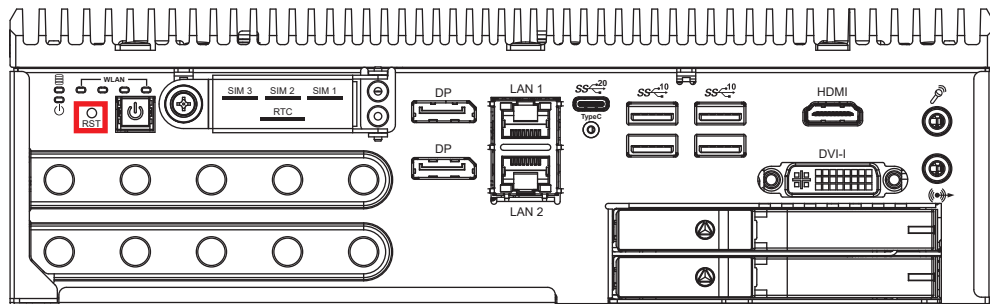

It is a hardware reset switch. Use this switch to reset the system without power off the system. Press the Reset Switch for a few seconds, then reset will be enabled.

## 2.2.2 Power Button

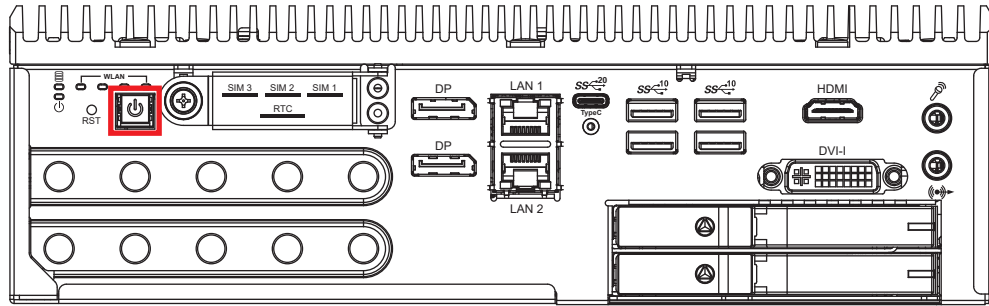

The Power Button is a non-latched switch with dual color LED indication. It indicates power status: S0, S3 and S5. More detail LED indications are listed as follows:

| LED Color    | Power Status | System Status                                 |
|--------------|--------------|---|
| Solid Blue   | S0           | System working                                |
| Solid Orange | S3, S5       | Suspend to RAM, System off with standby power |

To power on the system, press the power button and then the blue LED is lightened.

To power off the system, you can either command shutdown by OS operation, or just simply press the power button.

If system error, you can just press the power button for 4 seconds to shut down the machine directly.

Please do note that a 4-second interval between each 2 power-on/power-off operation is necessary in normal working status. (For example, once turning off the system, you have to wait for 4 seconds to initiate another power-on operation).

### 2.2.3 PWR & HDD LED Indicator

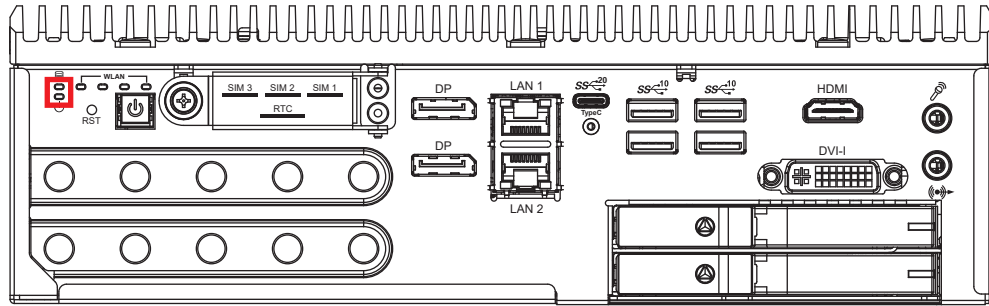

**HDD LED/Yellow :** A Hard Disk LED. If the LED is on, it indicates that the system's storage is functional. If it is off, it indicates that the system's storage is not functional. If it is flashing, it indicates data access activities.

**Power LED/Green :** If the LED is solid green, it indicates that the system is powered on.

| LED Color | Indication | System Status   |
|-----------|------------|---|
| Yellow    | HDD        | <ul style="list-style-type: none"> <li>On/Off : Storage status, function or not.</li> <li>Twinkling : Data transferring.</li> </ul> |
| Green     | Power      | System power status (on/off)  |

### 2.2.4 DVI-I Connector

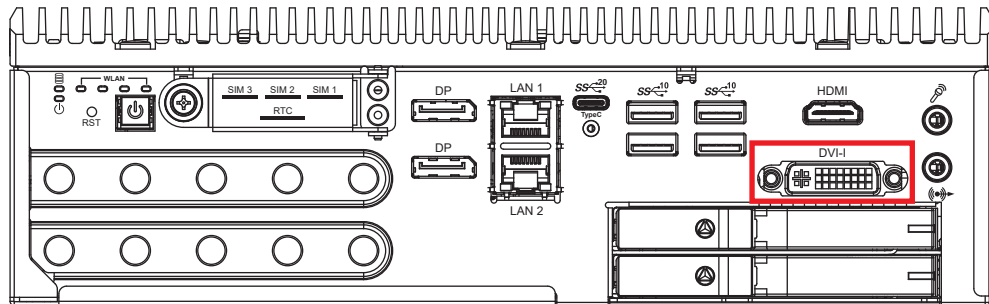

- The DVI-I connector on the front panel supports both DVI and VGA display modes.
- This connector can output DVI signals. The DVI output mode supports up to 1920x1200 resolution.
- The DVI mode is automatically selected according to the display device connected.
- You will need a DVI-I cable when connecting to a display device.
- The VGA output mode supports up to 1920x1200 resolution.
- If use VGA function will need a DVII to VGA module connecting to DVI-I device.
- Below is the DVII to VGA module picture



## 2.2.5 HDMI Connector

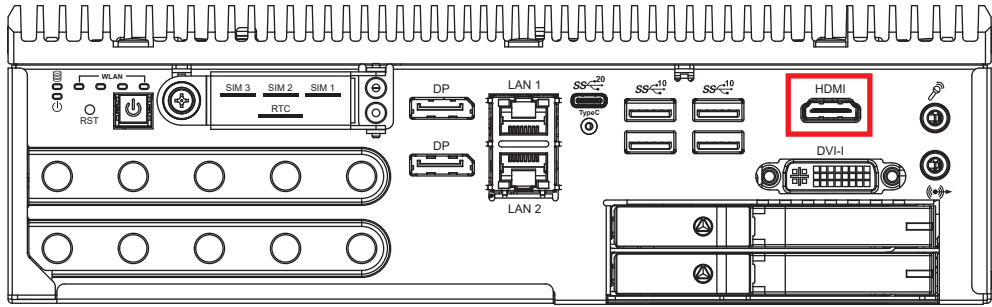

Onboard HDMI Port supports DDC channel mode. The connection supports up to 3840 x 2160 resolution at 30Hz.

## 2.2.6 DisplayPort

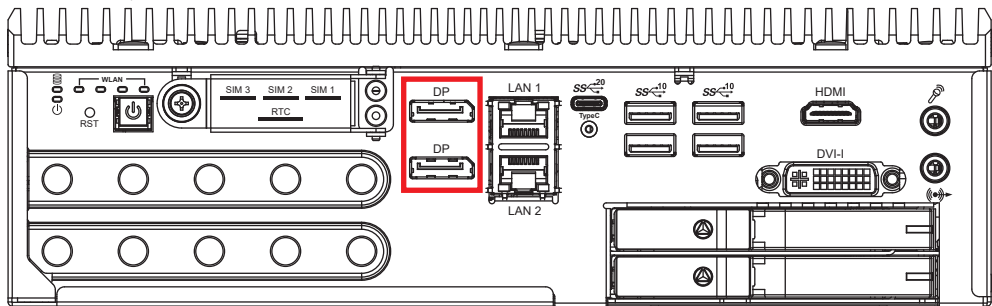

Onboard Display Port support auxiliary channel dual mode, connection supports up to 7680x4320 resolution at 60 Hz.

## 2.2.7 USB 3.2

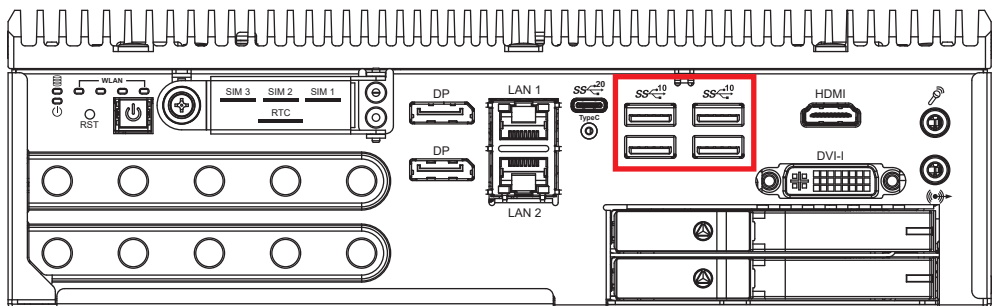

There are 4 USB 3.2 connections available supporting up to 10Gb per second data rate in the front side of ECX-3000 PEG series. It also compliant with the requirements of Super Speed (SS), high speed (HS), full speed (FS) and low speed (LS).

## 2.2.8 WLAN LED, Mini PCIe, M.2 KEY B, M.2 KEY M, Nano SIM Card Comparison

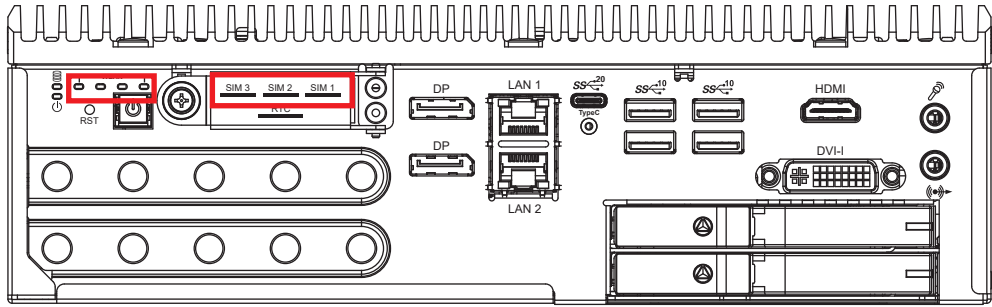

Mini PCIe Slot/ Nano SIM Slot/ M.2 KEY B/ M.2 KEY M / WLAN LED Mapping Table :

| Mini PCIe | SIM   | LED |
|-----------|-------|-----|
| MPCIe 1   | SIM 1 | 1   |
| M.2 KEY B | SIM 2 | 3   |
| M.2 KEY B | SIM 3 | 4   |
| M.2 KEY E | X     | 2   |

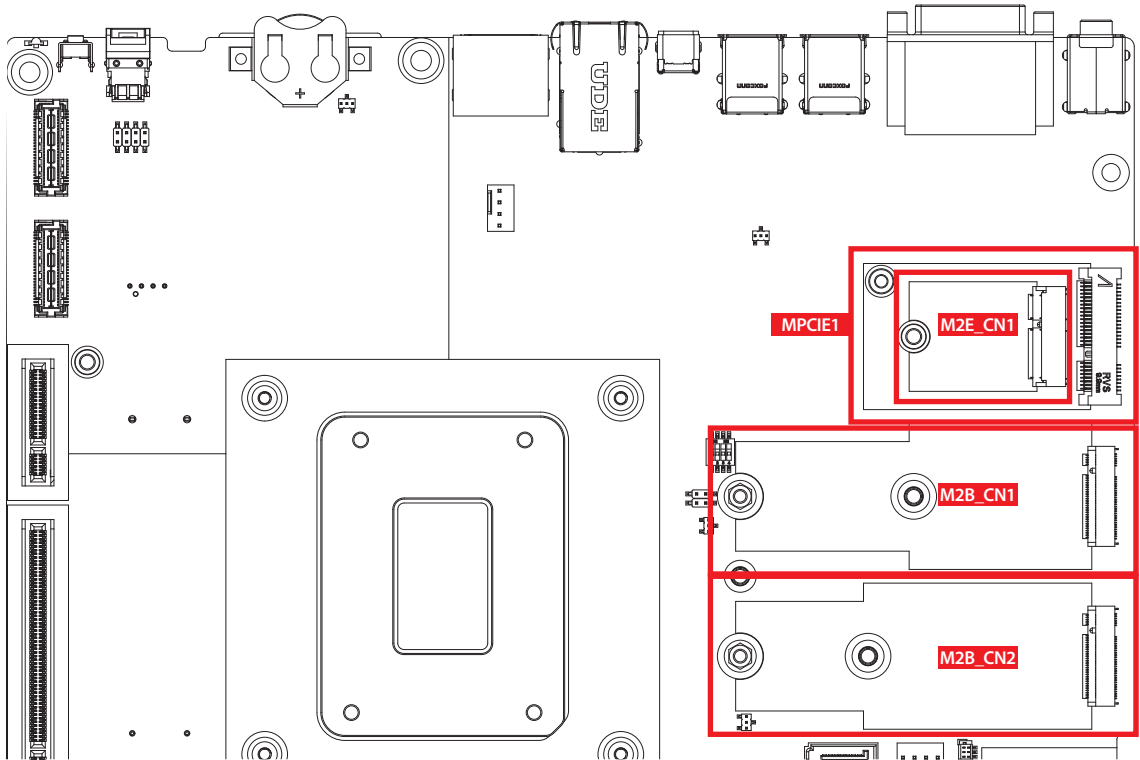

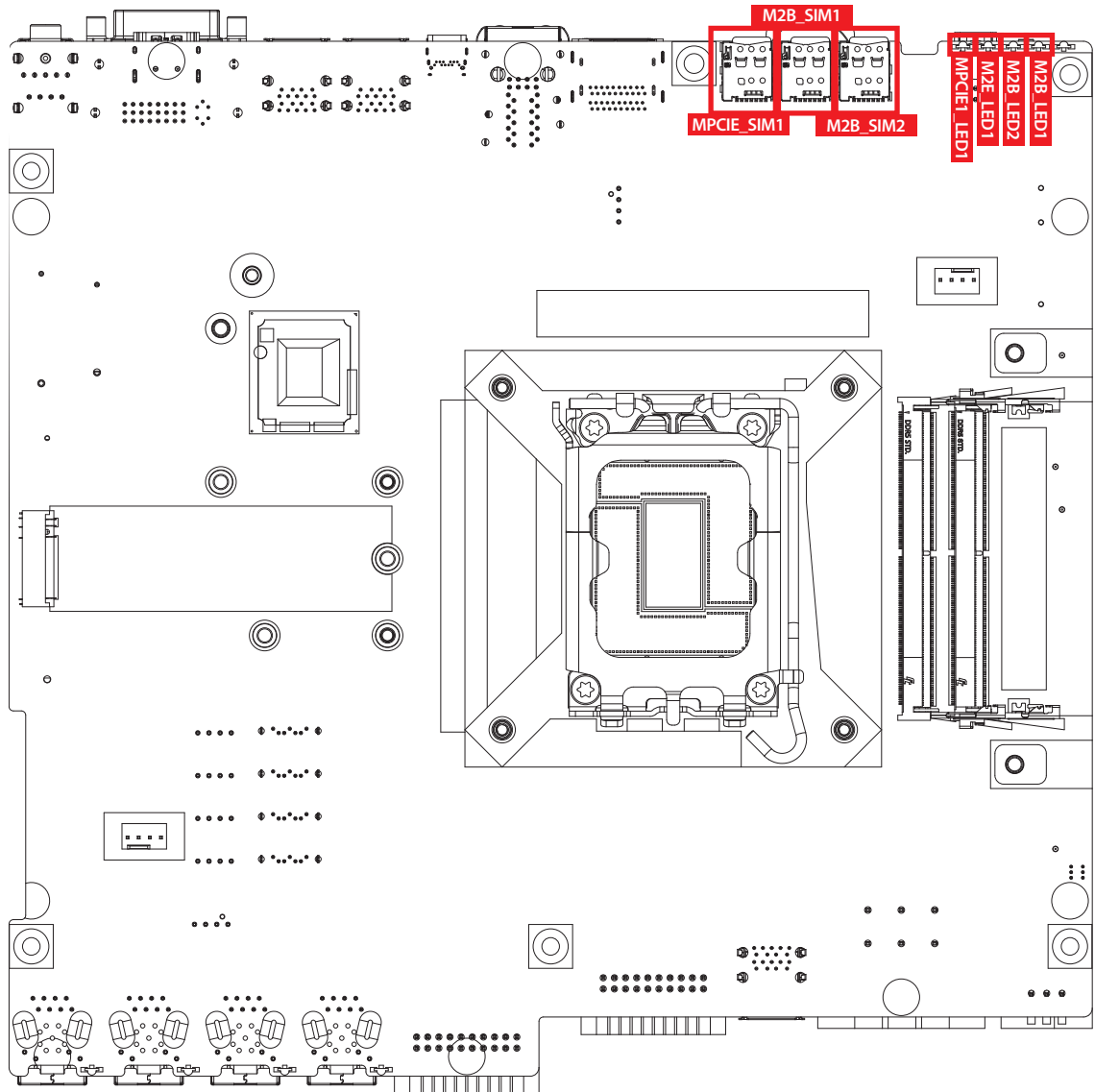

**Note :**

The SIM card sockets do not support hot-plug. Please make sure to unplug the system power before inserting the SIM card(s).

## 2.2.9 Ethernet Port

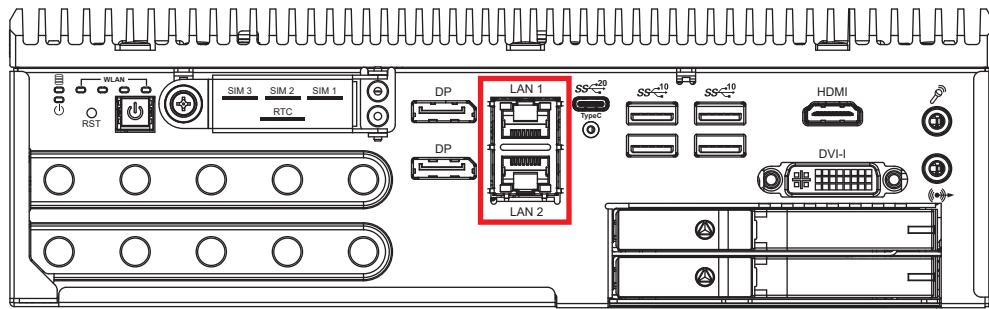

There are 2 8-pin RJ-45 jacks supporting 10/ 100/1000 Mbps Ethernet connections in the front side. LAN 1 is powered by Intel i219 Ethernet Phy; LAN 2 is powered by Intel I210 Ethernet engine. When both LAN 1 work in normal status, iAMT 11.0 function is enabled.

Using suitable RJ-45 cable, you can connect the system to a computer, or to any other devices with Ethernet connection, for example, a hub or a switch. Moreover, both of LAN 1 and LAN 2 supports Wake on LAN and Pre-boot functions. The pin-outs of LAN 1 and LAN 2 are listed as follows:

| Pin No. | 10/100 Mbps | 1000Mbps |
|---------|-------------|----------|
| 1       | E_TX+       | MDI0_P   |
| 2       | E_TX-       | MDI0_N   |
| 3       | E_RX+       | MDI1_P   |
| 4       | ----        | MDI2_P   |
| 5       | -----       | MDI2_N   |
| 6       | E_RX-       | MDI1_N   |
| 7       | -----       | MDI3_P   |
| 8       | -----       | MDI3_N   |

Each LAN port is supported by standard RJ-45 connector with LED indicators to present Active/Link/Speed status of the connection.

The LED indicator on the right bottom corner lightens in solid green when the cable is properly connected to a 100 Mbps Ethernet network; The LED indicator on the right bottom corner lightens in solid orange when the cable is properly connected to a 1000Mbps Ethernet network; The left LED will keep twinkling/off when Ethernet data packets are being transmitted/received.

| LED Location | LED Color        | 10Mbps             | 100Mbps            | 1000Mbps           |
|--------------|------------------|--------------------|--------------------|--------------------|
| Right        | Green/<br>Orange | Off                | Solid<br>Green     | Solid<br>Orange    |
| Left         | Green            | Twinkling<br>Green | Twinkling<br>Green | Twinkling<br>Green |

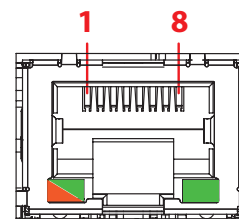

## 2.2.10 Audio Connector

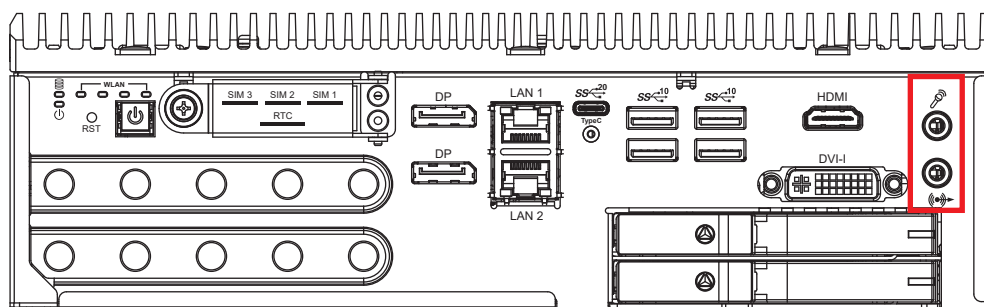

There are 2 audio connectors, Mic-in and Line-out, in the front side of ECX-3000PEG. Onboard Realtek ALC888 audio codec supports 7.1 channel HD audio and fully complies with Intel® High Definition Audio (Azalia) specifications.

To utilize the audio function in Windows platform, you need to install corresponding drivers for both Intel Sunrise Point chipset and Realtek ALC888S-VD codec.

## 2.2.11 SSD/HDD Tray

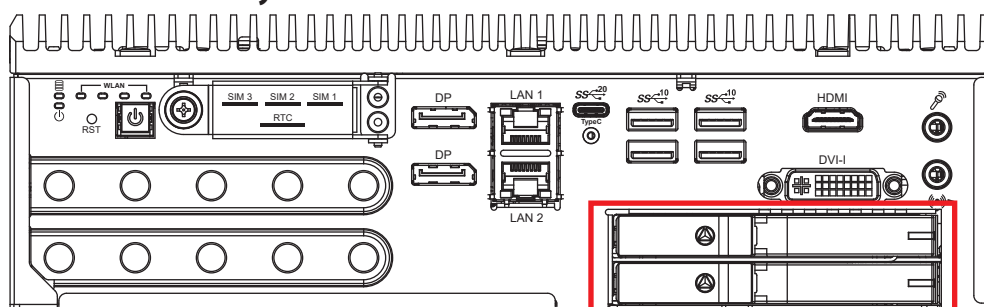

There are 4 front-access 2.5" SSD/HDD trays in the front side of ECX-3800/3600/3400 PEG series and 2 front-access 2.5" SSD/HDD trays in the front side of ECX-3200/3200MX/3100 PEG. Just trigger to open the SSD/HDD tray, up to 4TB is available



## 2.2.12 USB TYPE-C Connector

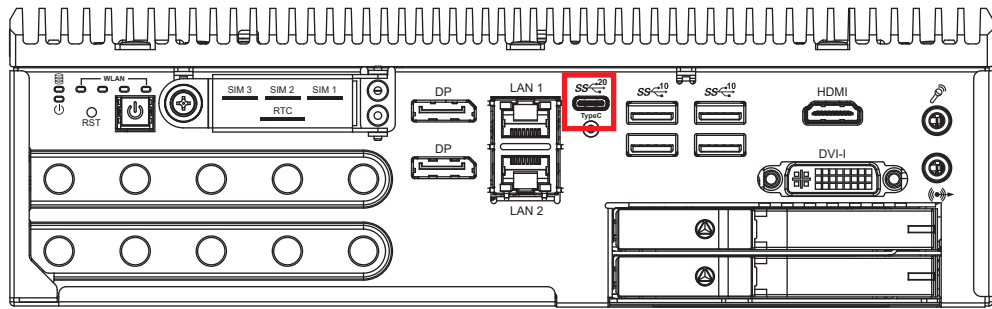

USB Type-C connector support up to 20Gb per second data rate in the front side of ECX-3000 PEG series.

## 2.3 Rear Panel I/O & Functions

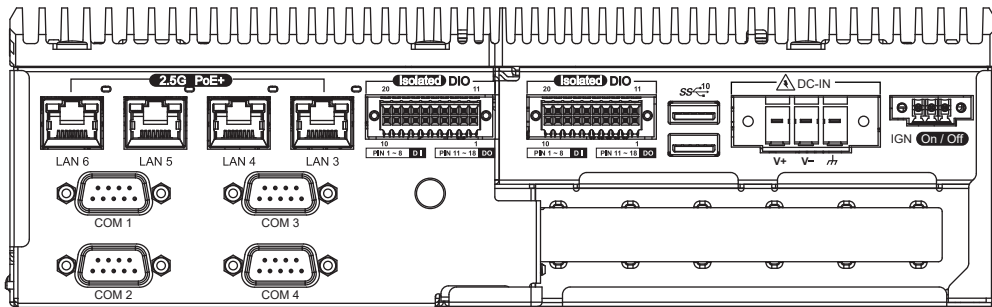

### 2.3.1 Power Terminal Block

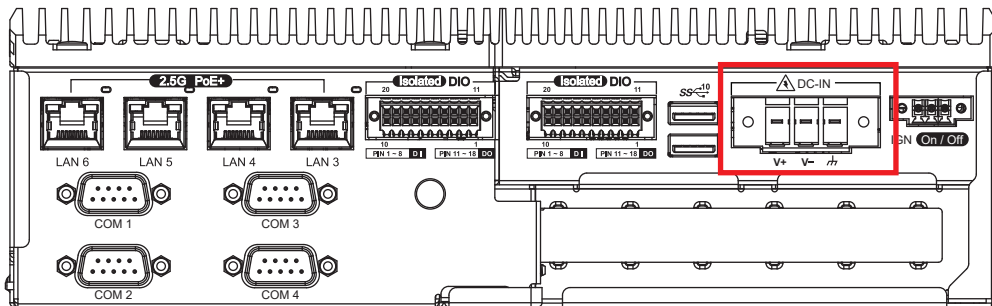

This system supports 12V to 50V DC power input by terminal block in the rear side. In normal power operation, power LED lightens in solid green. Supports up to 80V surge protection.

| Pin No. | Definition     | Pin No. | Definition |
|---------|----------------|---------|------------|
| 1       | V+             | 2       | V-         |
| 3       | Chassis Ground |         |            |

## 2.3.2 Remote Power On/Off Switch Terminal Block

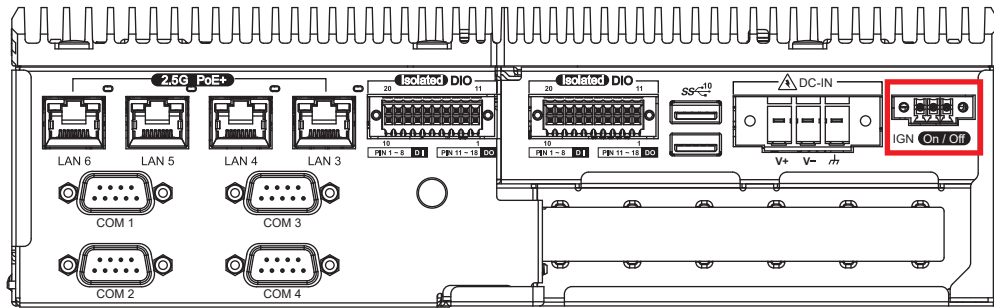

It is a 3-pin power-on or power-off switch through Phoenix Contact terminal block. You could turn on or off the system power by using this contact. This terminal block supports dual function of soft power-on/ power-off (instant off or delay 4 second), and suspend mode.

| Pin No. | Definition | Pin No. | Definition |
|---------|------------|---------|------------|
| 1       | Ignition   | 2       | SW+        |
| 3       | SW-        |         |            |

## 2.3.3 Isolated DIO

### 2.3.3.1 ECX-3800/3600/3400/3200/3200MX PEG Series

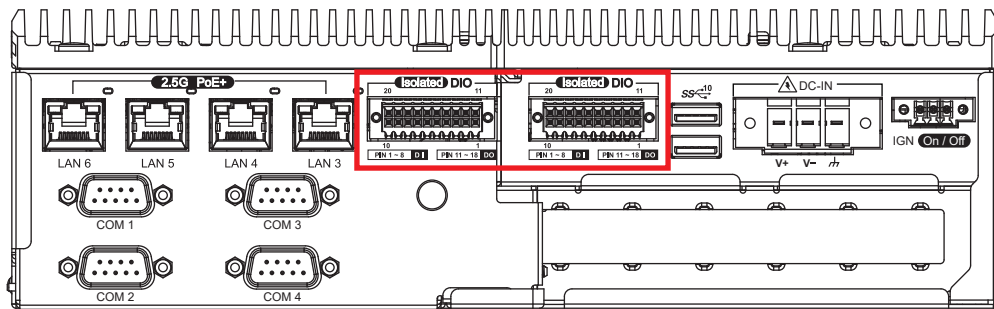

There is a 16-bit (8-bit DI, 8-bit DO) connectors in the rear side. DI/DIO support NPN (sink) and PNP (Source) mode, Each DI channel is equipped with a photocoupler for isolated protection. Each DO with isolator chip, Config by a Jumper for each DIO connector. DO Safety-Related Certifications :

- 4242-VPK Basic Isolation per DIN V VDE V 0884-10 and DIN EN 61010-1
- 3-KVRMS Isolation for 1 minute per UL 1577
- CSA Component Acceptance Notice 5A, IEC 60950-1 and IEC 61010-1 End Equipment Standards
- GB4943.1-2011 CQC Certified

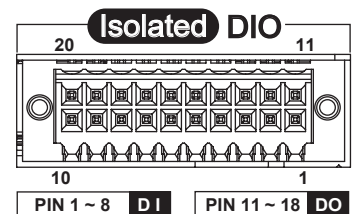

DIO1 Connectors pin out:

| Pin Number | Definition                                       | Mapping to SIO GPIO Function |
|------------|--|------------------------------|
| 1          | INPUT 0  | SIO_GPI80                    |
| 2          | INPUT 1  | SIO_GPI81                    |
| 3          | INPUT 2  | SIO_GPI82                    |
| 4          | INPUT 3  | SIO_GPI83                    |
| 5          | INPUT 4  | SIO_GPI84                    |
| 6          | INPUT 5  | SIO_GPI85                    |
| 7          | INPUT 6  | SIO_GPI86                    |
| 8          | INPUT 7  | SIO_GPI87                    |
| 9          | DI_COM   | -                            |
| 10         | DIO_GND  | -                            |
| 11         | OUTPUT 0   | SIO_GPO70                    |
| 12         | OUTPUT 1   | SIO_GPO71                    |
| 13         | OUTPUT 2   | SIO_GPO72                    |
| 14         | OUTPUT 3   | SIO_GPO73                    |
| 15         | OUTPUT 4   | SIO_GPO74                    |
| 16         | OUTPUT 5   | SIO_GPO75                    |
| 17         | OUTPUT 6   | SIO_GPO76                    |
| 18         | OUTPUT 7   | SIO_GPO77                    |
| 19         | DIO_GND  | -                            |
| 20         | External 6-40VDC (NPN)<br>External 6-48VDC (PNP) | -                            |

DIO2 Connectors pin out:

| Pin Number | Definition                                       | Mapping to SIO GPIO Function |
|------------|--|------------------------------|
| 1          | INPUT 0  | SIO_GPA3                     |
| 2          | INPUT 1  | SIO_GPI56                    |
| 3          | INPUT 2  | SIO_GPI57                    |
| 4          | INPUT 3  | SIO_GPI15                    |
| 5          | INPUT 4  | SIO_GPI16                    |
| 6          | INPUT 5  | SIO_GPI35                    |
| 7          | INPUT 6  | SIO_GPI46                    |
| 8          | INPUT 7  | SIO_GPI11                    |
| 9          | DI2_COM  | -                            |
| 10         | DIO2_GND   | -                            |
| 11         | OUTPUT 0   | SIO_GPO22                    |
| 12         | OUTPUT 1   | SIO_GPO26                    |
| 13         | OUTPUT 2   | SIO_GPO64                    |
| 14         | OUTPUT 3   | SIO_GPO65                    |
| 15         | OUTPUT 4   | SIO_GPO41                    |
| 16         | OUTPUT 5   | SIO_GPA5                     |
| 17         | OUTPUT 6   | SIO_GPA4                     |
| 18         | OUTPUT 7   | SIO_GPO27                    |
| 19         | DIO2_GND   | -                            |
| 20         | External 6-40VDC (NPN)<br>External 6-48VDC (PNP) | -                            |

### DI Reference Circuit :

Sink Mode (NPN)

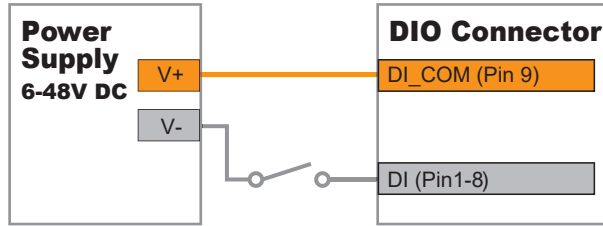

Source Mode (PNP)

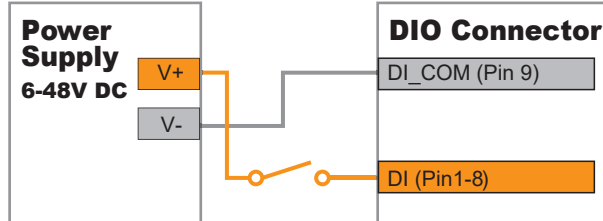

### DO reference circuit :

Sink Mode (NPN, Default)

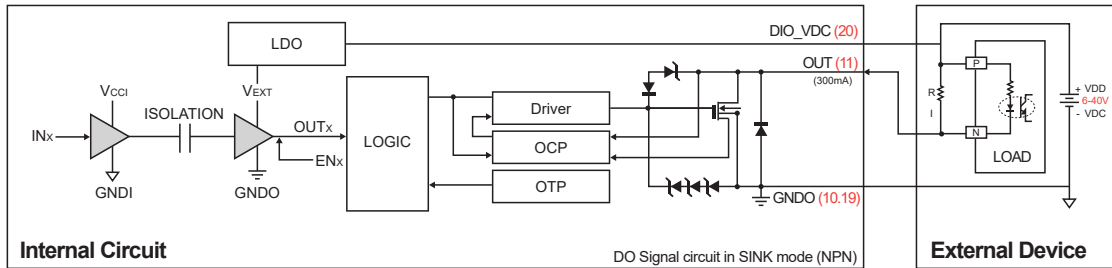

Source (PNP)

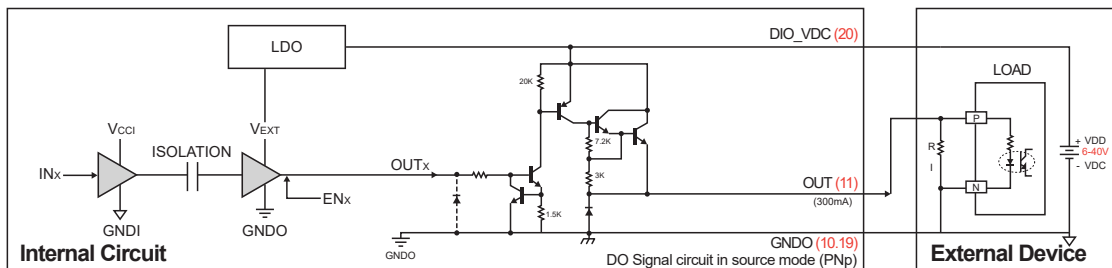

### 2.3.3.2 ECX-3100 PEG series

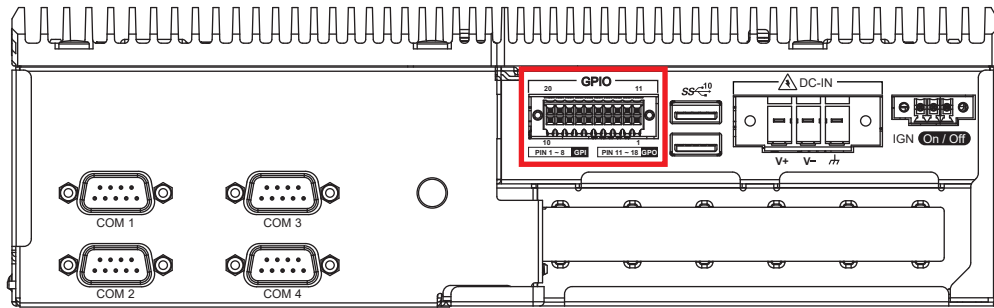

The system offers sixteen programmable I/O (3.3V Level).

If the GPIO is logic high, it indicates that the mapping SIO GPIO pin is logic high level.

If the GPIO is logic low, it indicates that the mapping SIO GPIO pin is logic low level.

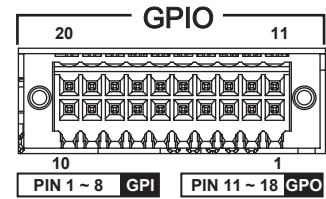

GPIO Connectors pin assignments

| Pin No. | Definition | Pin No. | Definition |
|---------|------------|---------|------------|
| 1       | SIO_GPA3   | 11      | SIO_GPO22  |
| 2       | SIO_GPI56  | 12      | SIO_GPO26  |
| 3       | SIO_GPI57  | 13      | SIO_GPO64  |
| 4       | SIO_GPI15  | 14      | SIO_GPO65  |
| 5       | SIO_GPI16  | 15      | SIO_GPO41  |
| 6       | SIO_GPI35  | 16      | SIO_GPA5   |
| 7       | SIO_GPI46  | 17      | SIO_GPA4   |
| 8       | SIO_GPI11  | 18      | SIO_GPO27  |
| 9       | -          | 19      | GND        |
| 10      | GND        | 20      | -          |

### 2.3.4 Serial Port

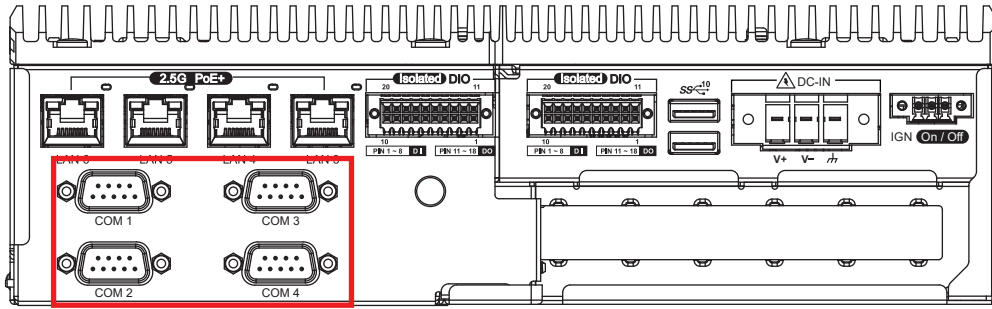

Serial port 1 to 4 (COM 1 to 4) can be configured for RS-232, RS-422, or RS-485 with auto flow control communication. The default definition of COM 1 and COM 2 is RS-232, if you want to change to RS-422 or RS-485, you can find the setting in BIOS.

| BIOS Setting | Function                     |
|--------------|------------------------------|
| COM 1        | RS-232                       |
| COM 2        | RS-422 (5-wire)              |
| COM 3        | RS-485                       |
| COM 4        | RS-485 w/z auto-flow control |

The pin assignments are listed in the following table :

| Serial Port | Pin No. | RS-232 | RS-422 (5-wire) | RS-485 (3-wire) |
|-------------|---------|--------|-----------------|-----------------|
| 1 to 4      | 1       | DCD    | TXD-            | DATA-           |
|             | 2       | RXD    | TXD+            | DATA+           |
|             | 3       | TXD    | RXD+            | -               |
|             | 4       | DTR    | RXD-            | -               |
|             | 5       | GND    | GND             | GND             |
|             | 6       | DSR    | -               | -               |
|             | 7       | RTS    | -               | -               |
|             | 8       | CTS    | -               | -               |
|             | 9       | RI     | -               | -               |



COM 1 to COM 4 MB connector table :

| COM Port | MB Connector | COM Port | MB Connector |
|----------|--------------|----------|--------------|
| COM 1    | JCOM1        | COM 2    | JCOM2        |
| COM 3    | JCOM3        | COM 4    | JCOM4        |

| CN             | Pin No. | Signal Name |
|----------------|---------|-------------|
| JCOM1 to JCOM4 | 1       | NC          |
|                | 2       | GND         |
|                | 3       | RI          |
|                | 4       | DTR         |
|                | 5       | CTS         |
|                | 6       | TXD         |
|                | 7       | RTS         |
|                | 8       | RXD         |
|                | 9       | DSR         |
|                | 10      | DCD         |

### 2.3.5 PoE Ports

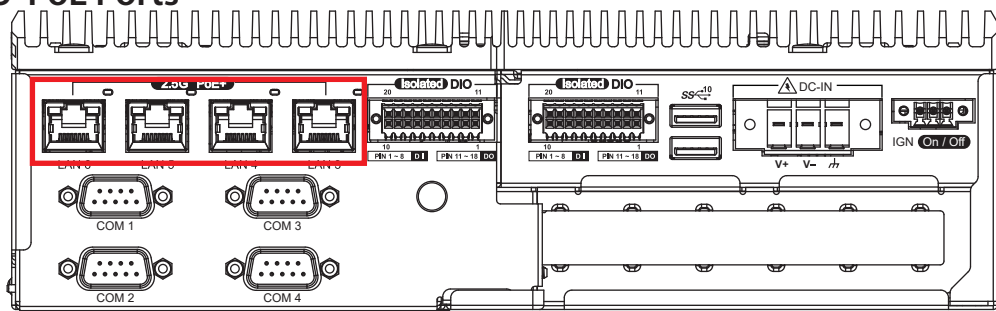

There are 4 RJ45 connectors in the rear side of ECX-3000-PEG. It supports IEEE 802.3at (PoE+) Power over Ethernet (PoE) connection delivering up to 37W/54V per port and 1000BASE-T gigabit data signals over standard Ethernet Cat 5/Cat 6 cable.

Each PoE connection is powered by Intel® I226 2.5Gigabit Ethernet controller and independent PCI express interface to connect with multi-core processor for network and data transmit optimization. Only when PoE port starts to supply power to power devices, the dedicated LED will be lightened.

**PS.** Suggest to use PoE function when power input is over 12V.

The pin-outs of LAN 3 and LAN 6 are listed as follows :

| Pin No. | 10/100 Mbps | 1000Mbps | PoE  |
|---------|-------------|----------|------|
| 1       | E_TX+       | MDI0_P   | PoE+ |
| 2       | E_TX-       | MDI0_N   | PoE+ |
| 3       | E_RX+       | MDI1_P   | PoE- |
| 4       | -           | MDI2_P   | -    |
| 5       | -           | MDI2_N   | -    |
| 6       | E_RX-       | MDI1_N   | PoE- |
| 7       | -           | MDI3_P   | -    |
| 8       | -           | MDI3_N   | -    |

Each LAN port is supported by standard RJ-45 connector with LED indicators to present Active/Link/Speed status of the connection.

The LED indicator on the right bottom corner lightens in solid green when the cable is properly connected to a 100 Mbps Ethernet network; The LED indicator on the right bottom corner lightens in solid orange when the cable is properly connected to a 1000 Mbps Ethernet network; The left LED will keep twinkling/off when Ethernet data packets are being transmitted/ received.

| LED Location | LED Color     | 10/100 Mbps      | 1000 Mbps        | 2500 Mbps        |
|--------------|---------------|------------------|------------------|------------------|
| Right        | Yellow        | Twinkling Yellow | Twinkling Yellow | Twinkling Yellow |
| Left         | Green/ Orange | Off              | Solid Green      | Solid Orange     |

  

| POE LED   | LED Color   | POE Status |
|-----------|-------------|------------|
| LED 1 - 4 | Solid Green | POE ON     |

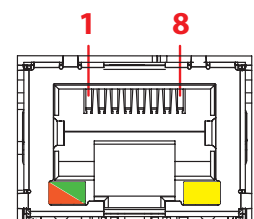

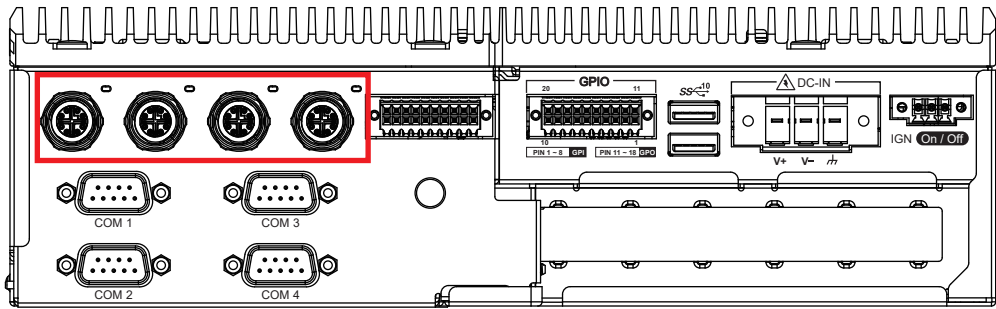

There are 4 M12 connectors in the rear side of ECX-3200MX PEG. It supports IEEE 802.3at (PoE+) Power over Ethernet (PoE) connection delivering up to 25W/54V per port and 1000BASE-T gigabit data signals over standard Ethernet Cat 5/Cat 6 cable.

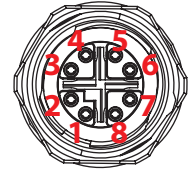

| M12 X-Code Pin No. | 10/100 Mbps | 1000Mbps | PoE  |
|--------------------|-------------|----------|------|
| 1                  | E_TX+       | MDI0_P   | PoE+ |
| 2                  | E_TX-       | MDI0_N   | PoE+ |
| 3                  | E_RX+       | MDI1_P   | PoE- |
| 4                  | E_RX-       | MDI1_N   | PoE- |
| 8                  | -           | MDI2_P   | -    |
| 7                  | -           | MDI2_N   | -    |
| 5                  | -           | MDI3_P   | -    |
| 6                  | -           | MDI3_N   | -    |

## 2.4 Main Board Expansion Connectors

### 2.4.1 Top View (Component Side) of ECX-3000 PEG Main Board With Connector Location

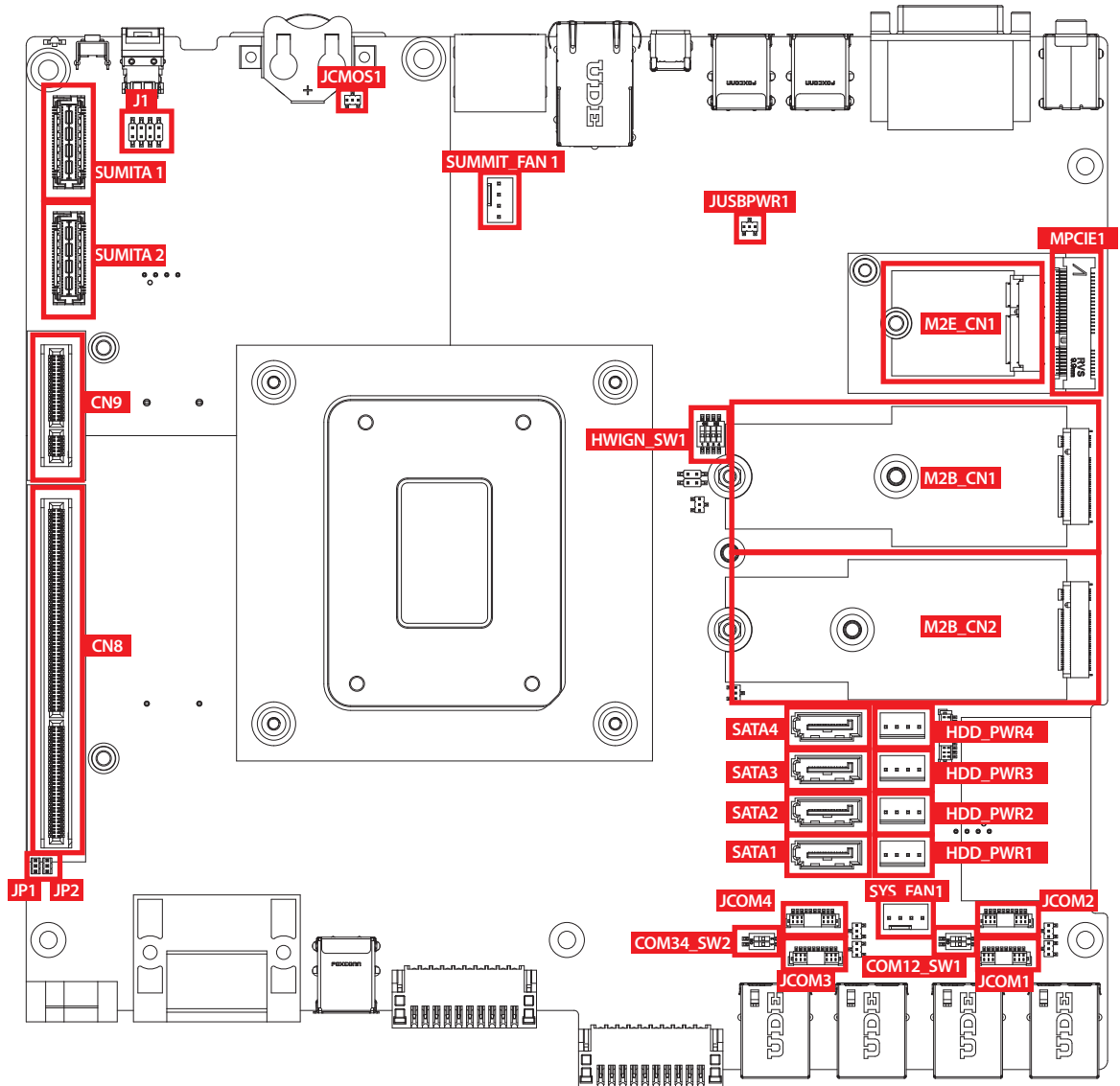

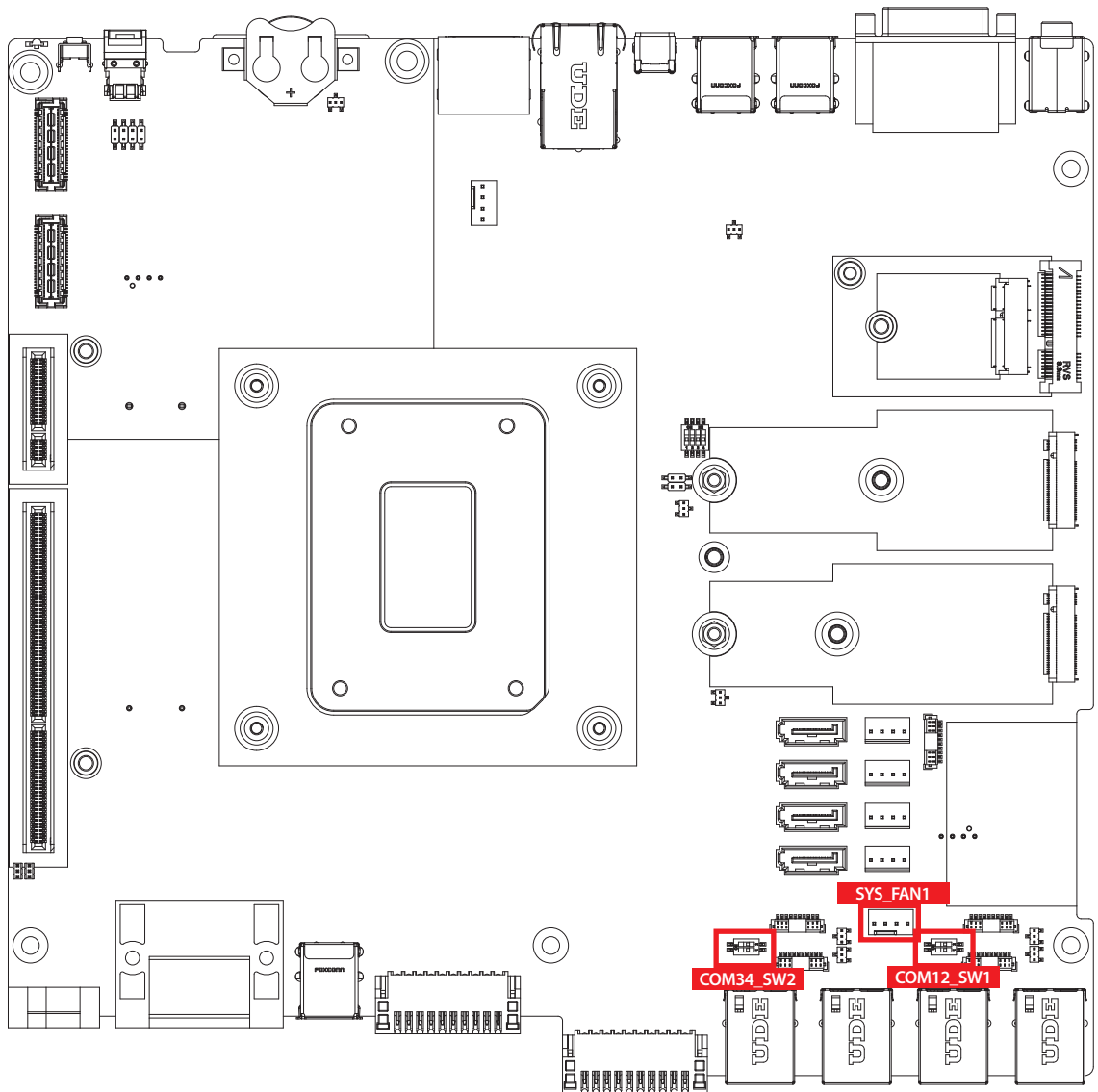

## 2.4.2 Bottom View (Solder Side) of ECX-3000-PEG Main Board With Connector Location

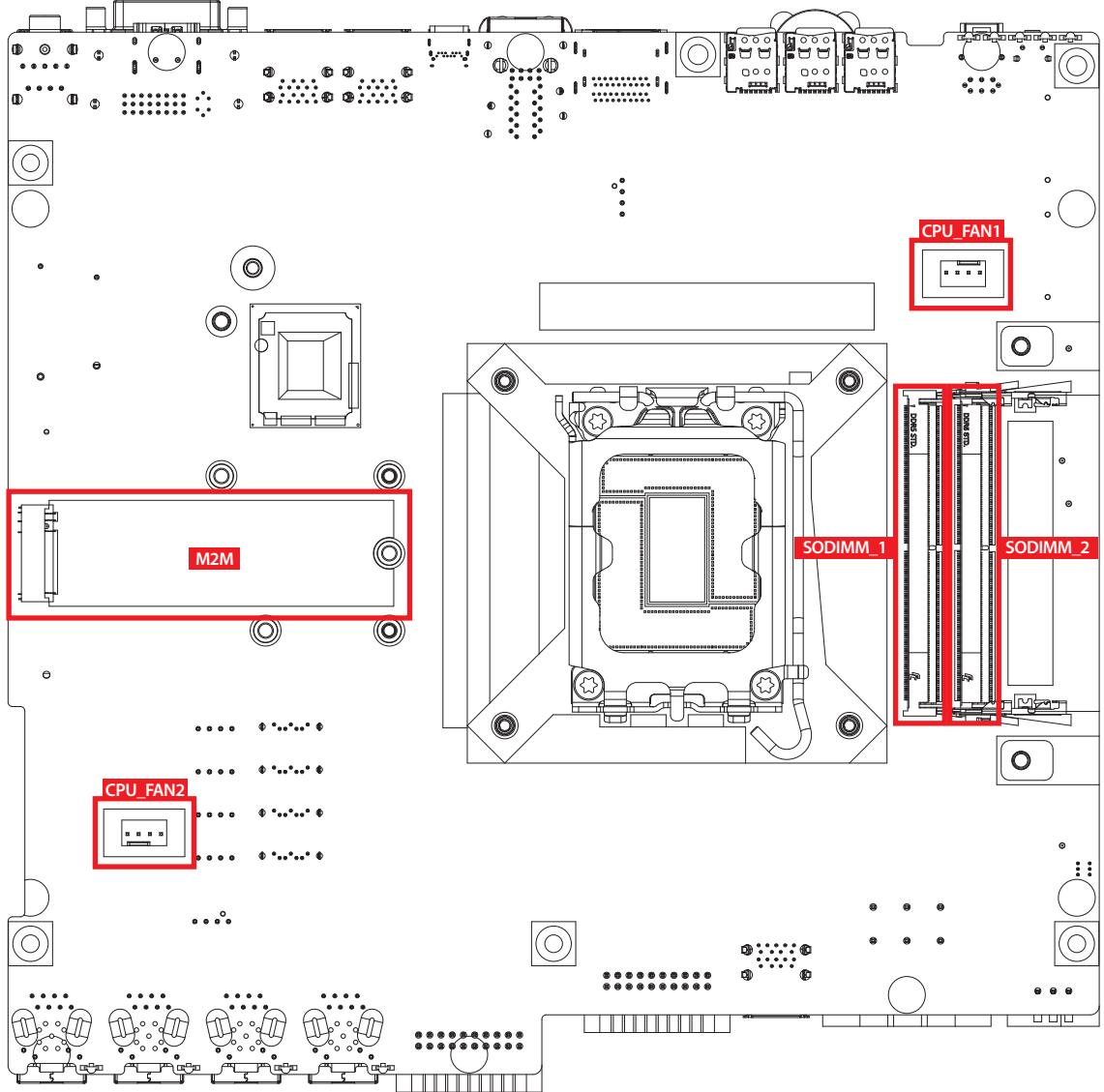

### 2.4.3 J1 : Miscellaneous Pin Header

2.0mm 2x4p header

This pin header can be used as a backup for following functions, hard drive LED indicator, reset button, power LED indicator, and power-on/off button, which already can be accessed by front panel and top panel. The pin-outs of Miscellaneous port are listed in following table:

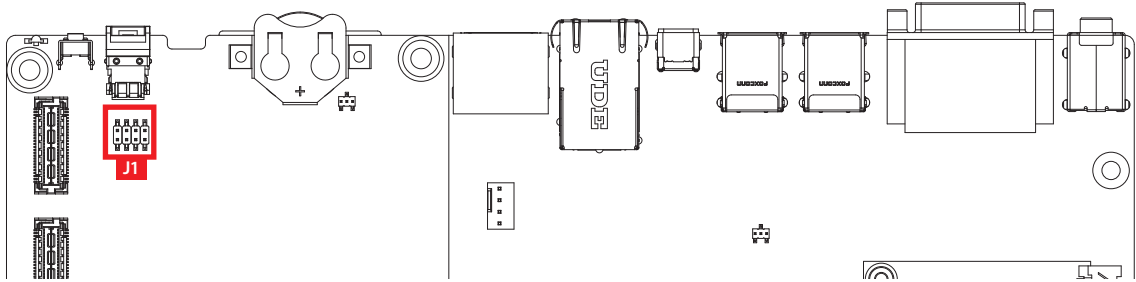

|  | Group        | Pin No. | Description   |
|--|--------------|---------|---------------|
|  | HDD LED      | 1       | HDD_LED_P     |
|  |              | 3       | HDD_LED_N     |
|  | RESET BUTTON | 5       | FP_RST_BTN_N  |
|  |              | 7       | Ground        |
|  | POWER LED    | 2       | PWR_LED_P     |
|  |              | 4       | PWR_LED_N     |
|  | POWER BUTTON | 6       | FP_PWR_BTN_IN |
|  |              | 8       | Ground        |

## 2.4.4 SATA1 to SATA4: SATA III Connector

There are 4 onboard high performance Serial ATA III (SATA III) on ECX-3000 PEG. It supports higher storage capacity with less cabling effort and smaller required space. The pin assignments of SATA1 to SATA4 are listed in the following table :

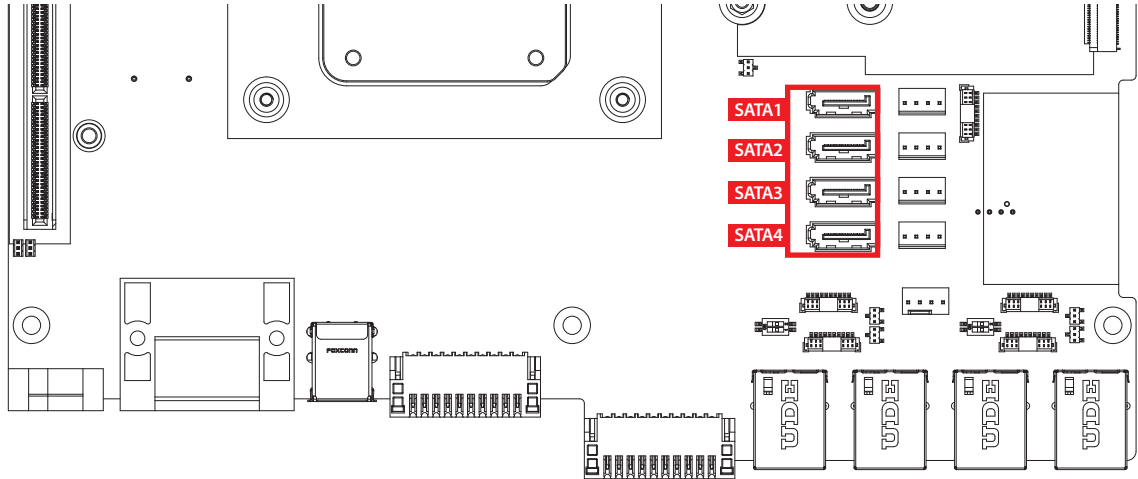

| 7 1 |  | Pin No. | Definition | Pin No. | Definition |
|-----|--|---------|------------|---------|------------|
|     |  | 1       | GND        | 5       | RXN        |
|     |  | 2       | TXP        | 6       | RXP        |
|     |  | 3       | TXN        | 7       | GND        |
|     |  | 4       | GND        |         |            |

## 2.4.5 HDD\_PWR1 to HDD\_PWR4 : SATA Power Connector

The ECX-3000 PEG also equip with 4 SATA power connector. Each port supports 5V (Up to 2A) and 12V (Up to 2A) current to the hard drive or SSD. The pin assignments of HDD\_PWR1 to HDD\_PWR4 are listed in the following table:

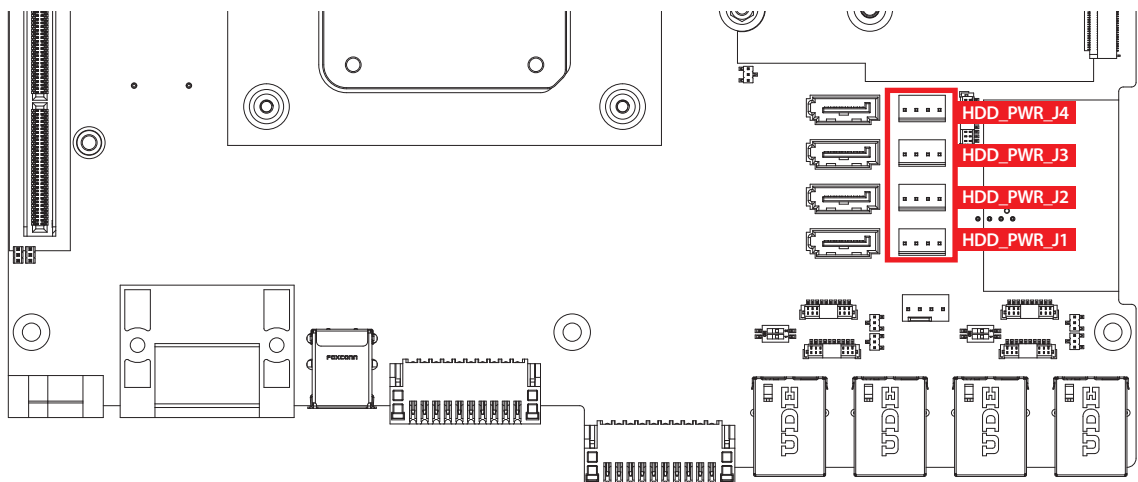

| 1 4 |  | Pin No. | Definition | Pin No. | Definition |
|-----|--|---------|------------|---------|------------|
|     |  | 1       | +12V       | 3       | GND        |
|     |  | 2       | GND        | 4       | +5V        |



### 2.4.6 SODIMM\_1, SODIMM\_1 : DDR5 Slot

There are 2 DDR5 channel onboard, support DDR5 4800, max 64GB  
Each channel 32GB

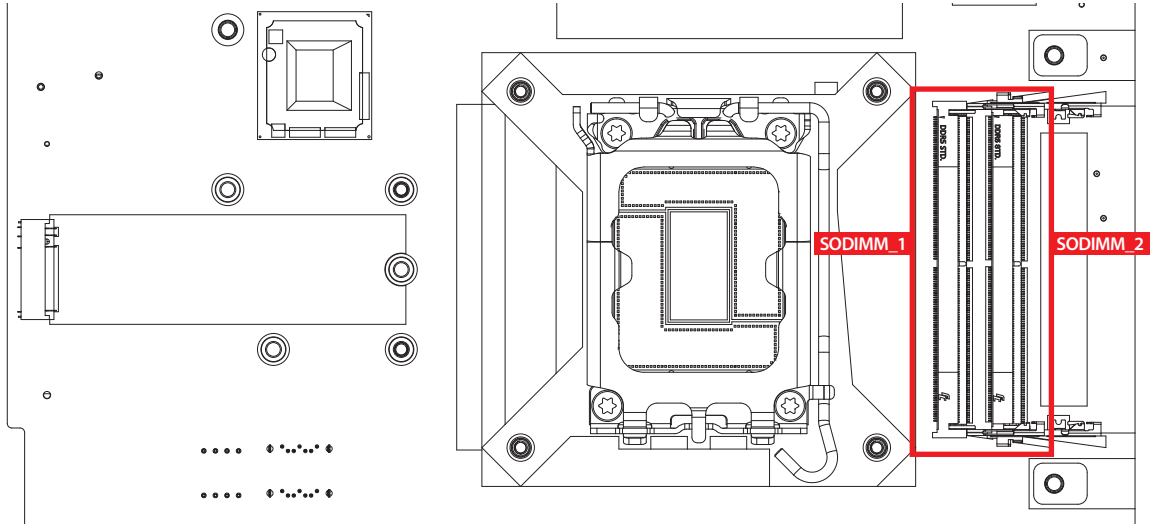

| Slot     | Description    |
|----------|----------------|
| SODIMM_1 | DDR5 Channel A |
| SODIMM_2 | DDR5 Channel B |

### 2.4.7 CN22 : BIOS\_CN1 : BIOS Socket

If the BIOS needs to be changed, please contact the Vecow RMA service team.

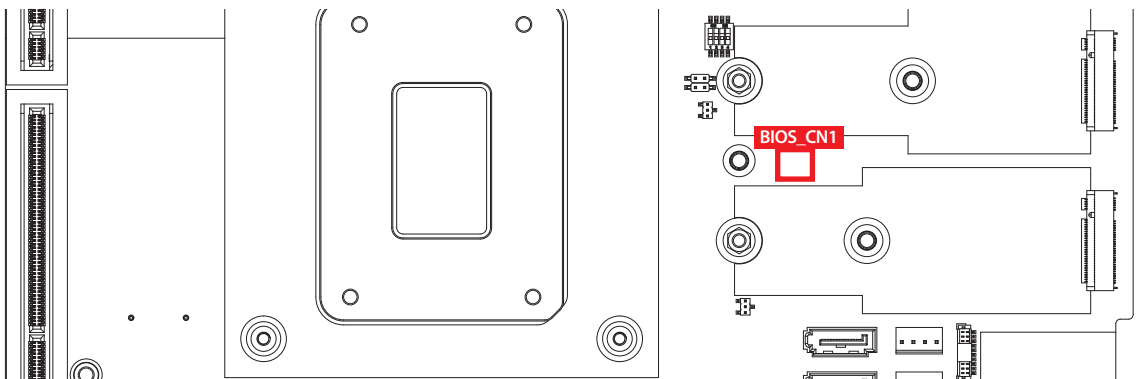

## 2.4.8 SUMITA1, SUMITB1

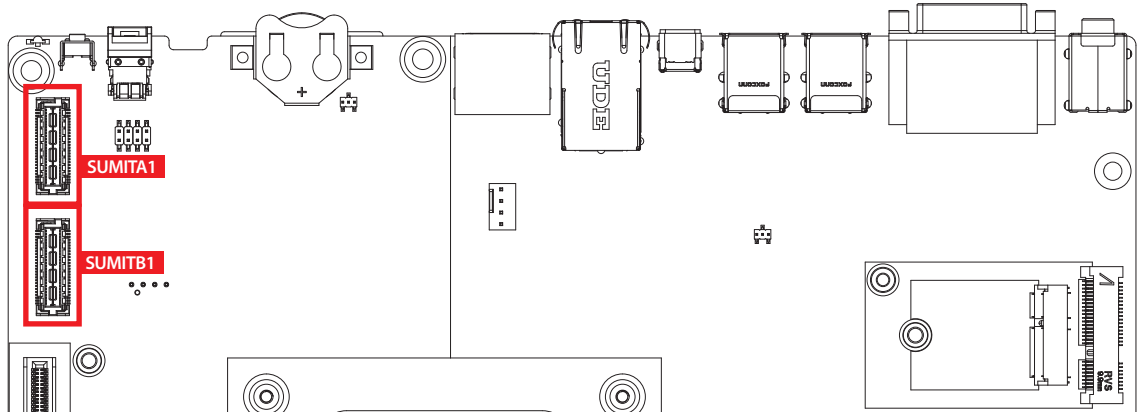

## 2.4.9 Mini PCIe : MPCIE1

Standard full length mini PCIe slot.

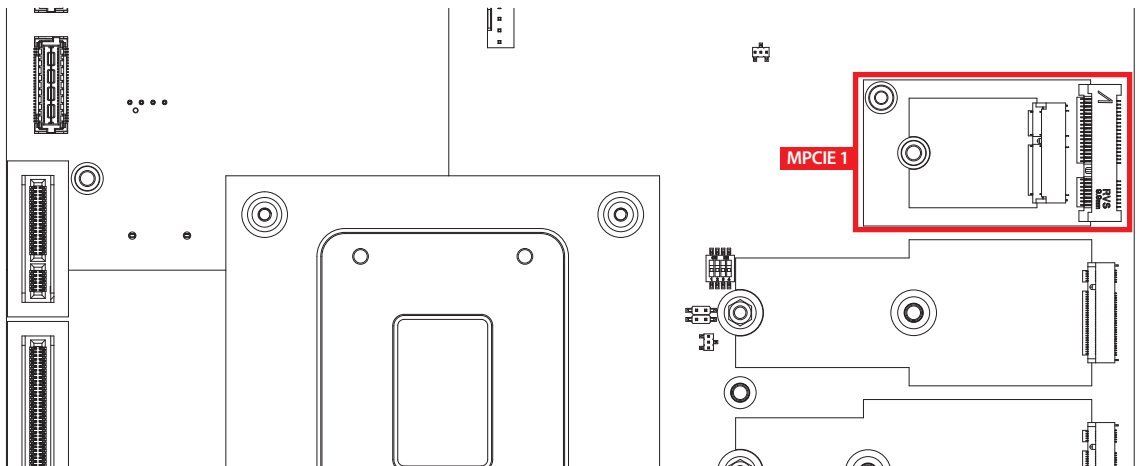

The pin assignments of MPCIE 1, MPCIE2 in the following table :

| Pin No. | Signal Name | Pin No. | Signal Name |
|---------|-------------|---------|-------------|
| 51      | Reserved    | 52      | +3.3Vaux    |
| 49      | Reserved    | 50      | GND         |
| 47      | Reserved    | 48      | +1.5V       |
| 45      | Reserved    | 46      | Reserved    |
| 43      | GND         | 44      | Reserved    |
| 41      | +3.3Vaux    | 42      | Reserved    |
| 39      | +3.3Vaux    | 40      | GND         |
| 37      | GND         | 38      | USB_D+      |
| 35      | GND         | 36      | USB_D-      |
| 33      | PETp0       | 34      | GND         |
| 31      | PETn0       | 32      | SMB_DATA    |

| Pin No.        | Signal Name | Pin No. | Signal Name |
|----------------|-------------|---------|-------------|
| 29             | GND         | 30      | SMB_CLK     |
| 27             | GND         | 28      | +1.5V       |
| 25             | PERp0       | 26      | GND         |
| 23             | PERn0       | 24      | +3.3Vaux    |
| 21             | GND         | 22      | PERST#      |
| 19             | Reserved    | 20      | reserved    |
| 17             | Reserved    | 18      | GND         |
| Mechanical Key |             |         |             |
| 15             | GND         | 16      | UIM_VPP     |
| 13             | REFCLK+     | 14      | UIM_RESET   |
| 11             | REFCLK-     | 12      | UIM_CLK     |
| 9              | GND         | 10      | UIM_DATA    |
| 7              | CLKREQ#     | 8       | UIM_PWR     |
| 5              | Reserved    | 6       | 1.5V        |
| 3              | Reserved    | 4       | GND         |
| 1              | WAKE#       | 2       | 3.3Vaux     |

## 2.4.10 CPU\_FAN1 : CPU\_FAN2 : FAN Header

Fan power connector supports for additional thermal requirements. The pin assignments of CPU\_FAN1 and CPU\_FAN2 are listed in the following table.

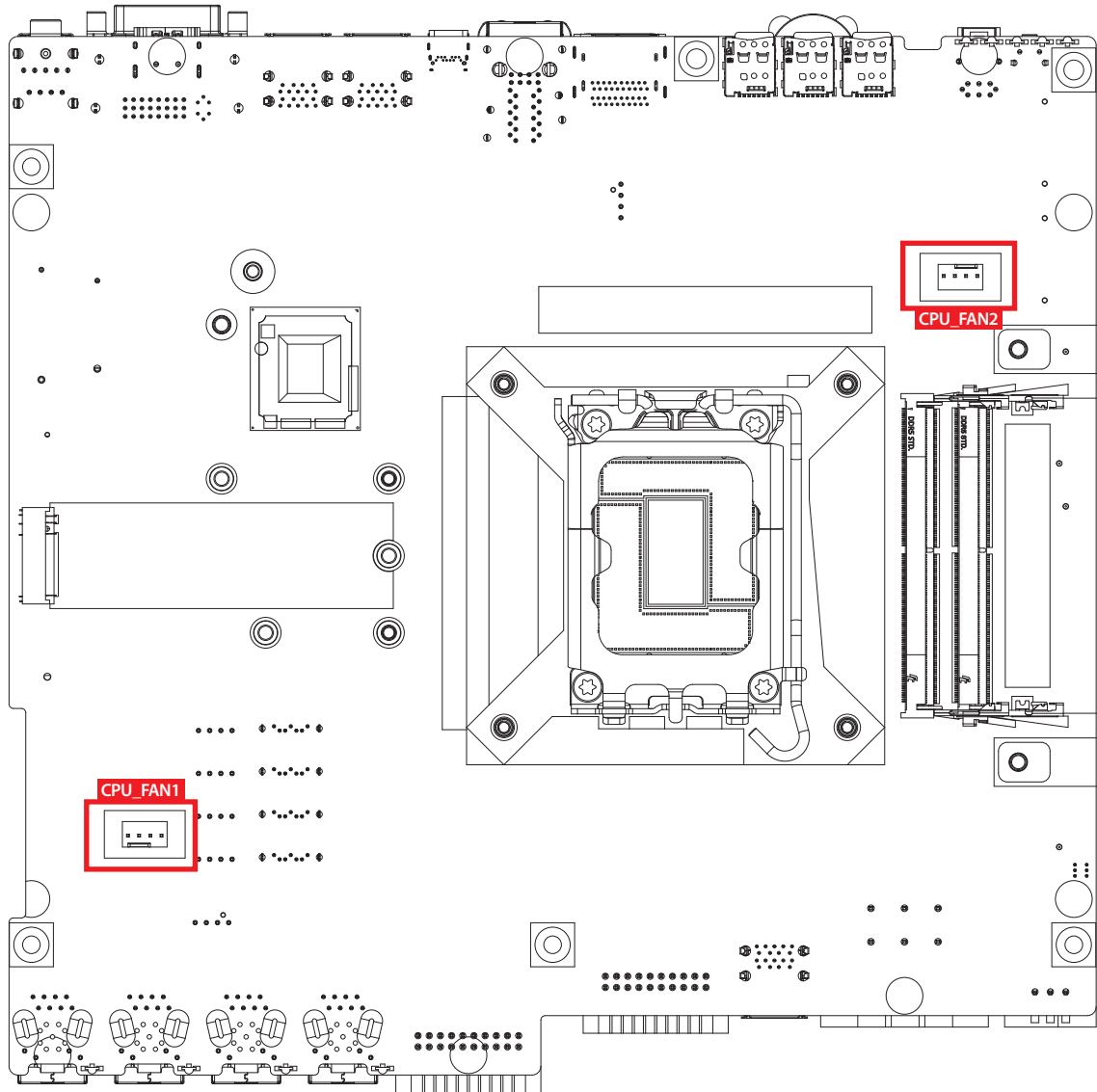

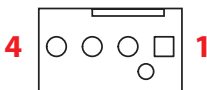
|  | Pin No. | Function         |
|---|---------|------------------|
|   | 1       | GND              |
|   | 2       | +12V (2A max)    |
|   | 3       | Fan speed sensor |
| 4   | Fan PWM |                  |

### 2.4.11 SYS\_FAN1 : System Fan Header

Fan power connector supports for additional PEG device. The pin assignments of SYS\_FAN1 is listed in the following table.

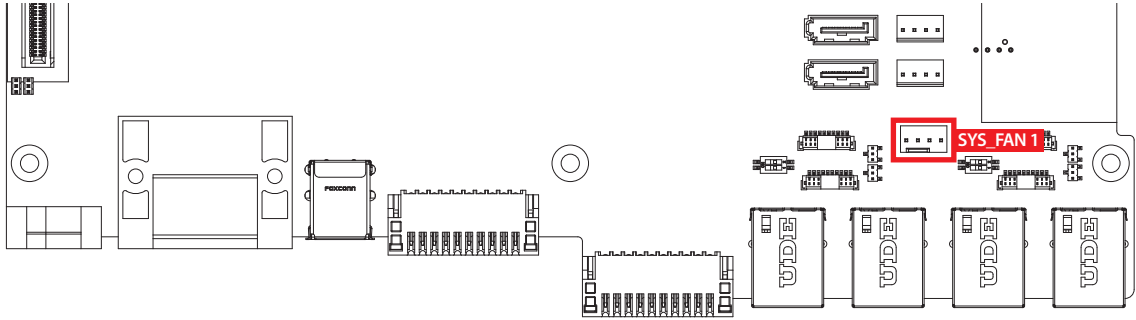

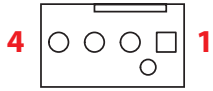
|  | Pin No. | Function         |
|---|---------|------------------|
|   | 1       | GND              |
|   | 2       | +12V (2A max)    |
|   | 3       | Fan Speed Sencer |
|   | 4       | Fan PWM          |

### 2.4.12 SUMIT\_FAN1 : SUMIT Fan Header

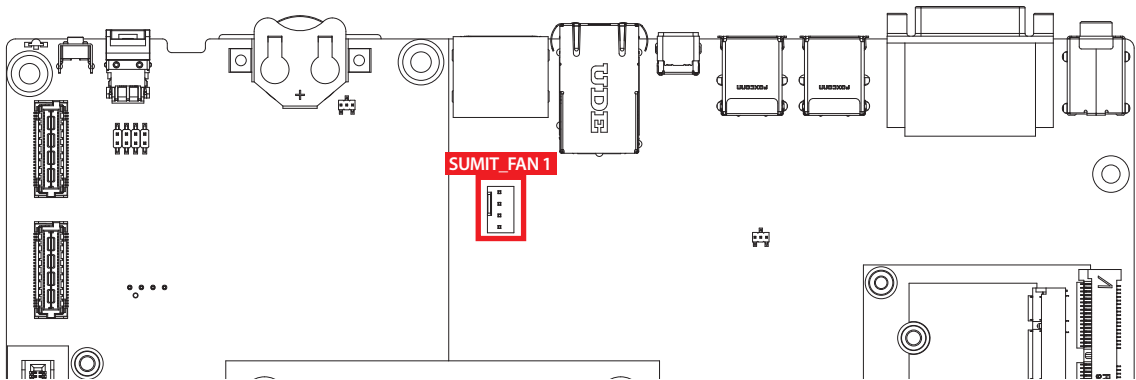

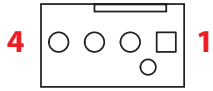
|  | Pin No. | Function     |
|---|---------|--------------|
|   | 1       | GND          |
|   | 2       | +12V(2A max) |
|   | 3       | NC           |
|   | 4       | NC           |

### 2.4.13 M2B\_CN1, M2B\_CN2 : M.2 slot

The pin assignments of M2B\_CN1, M2B\_CN2 in the following table :

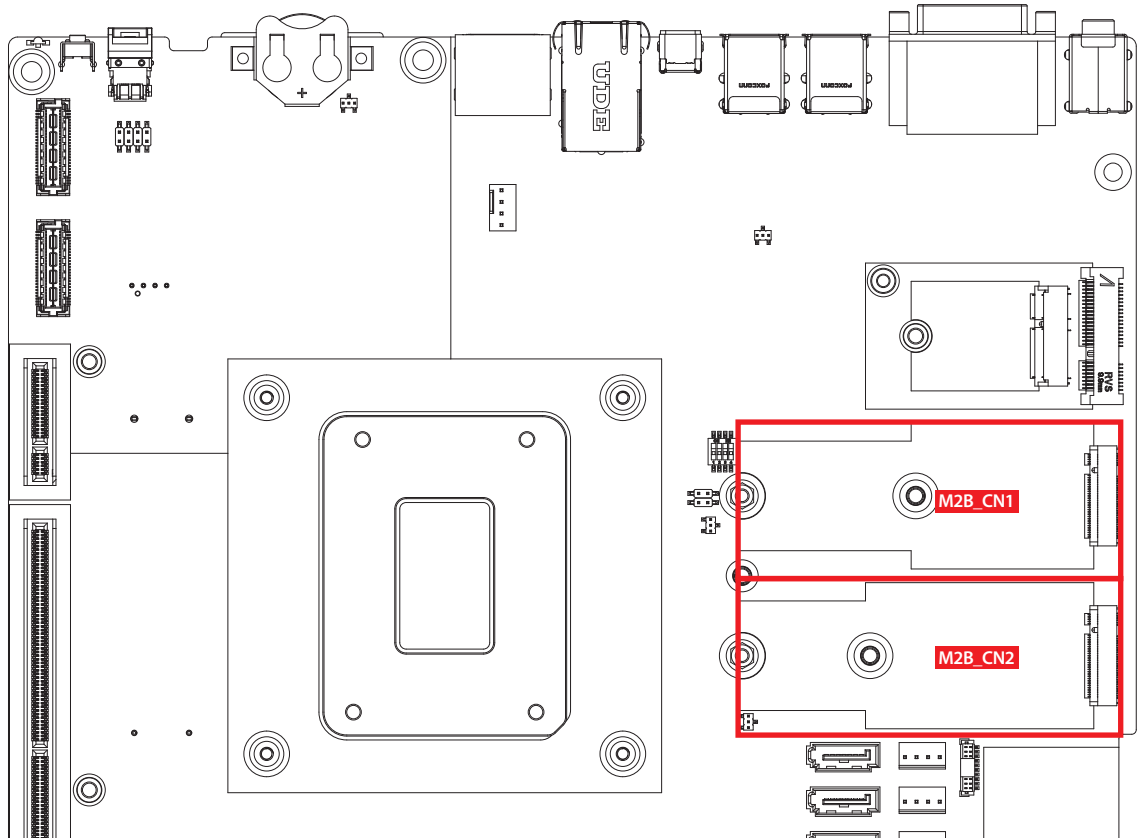

Module card types include 3042,3052.

M2B\_CN1, M2B\_CN2 : M.2 KEY B

| Pin No. | Signal Name | Pin No. | Signal Name |
|---------|-------------|---------|-------------|
|         |             | 80      | Ground      |
| 75      | NC          |         |             |
| 73      | Ground      | 74      | 3.3V        |
| 71      | Ground      | 72      | 3.3V        |
| 69      | CONFIG_1    | 70      | 3.3V        |
| 67      | NC          | 68      | NC          |
| 65      | NC          | 66      | SIM DETECT  |
| 63      | NC          | 64      | NC          |
| 61      | NC          | 62      | NC          |
| 59      | NC          | 60      | NC          |
| 57      | Ground      | 58      | NC          |
| 55      | REFCLKp     | 56      | NC          |
| 53      | REFCLKn     | 54      | PEWAKE#     |

| Pin No.        | Signal Name      | Pin No. | Signal Name              |
|----------------|------------------|---------|--------------------------|
| 51             | Ground           | 52      | CLKREQ#                  |
| 49             | PETp0/SATA-A+    | 50      | PERST#                   |
| 47             | PETn0/SATA-A-    | 48      | NC                       |
| 45             | Ground           | 46      | NC                       |
| 43             | PERp0/SATA-B-    | 44      | NC                       |
| 41             | PERn0/SATA-B+    | 42      | NC                       |
| 39             | Ground           | 40      | NC                       |
| 37             | PETp1/USB3.1-Tx+ | 38      | DEVSLP                   |
| 35             | PETn1/USB3.1-Tx- | 36      | UIM-PWR                  |
| 33             | Ground           | 34      | UIM-DATA                 |
| 31             | PERp1/USB3.1-Rx+ | 32      | UIM-CLK                  |
| 29             | PERn1/USB3.1-Rx- | 30      | UIM-RESET                |
| 27             | Ground           | 28      | NC                       |
| 25             | NC               | 26      | NC                       |
| 23             | NC               | 24      | NC                       |
| 21             | NC               | 22      | NC                       |
|                |                  | 20      | NC                       |
| Mechanical Key |                  |         |                          |
| 11             | Ground           |         |                          |
| 9              | USB-             | 10      | LED_1#                   |
| 7              | USB+             | 8       | W_DISABLE1               |
| 5              | Ground           | 6       | FULL_CARD_PWR_OFF/<br>ON |
| 3              | Ground           | 4       | 3.3V                     |
| 1              | NC               | 2       | 3.3V                     |

### 2.4.14 M.2 KEY M: PCIe x4

M.2 key M connector is suitable for applications that use Host I/Fs supported by either PCIe Module card types include 2280 (Only Support PCIE).

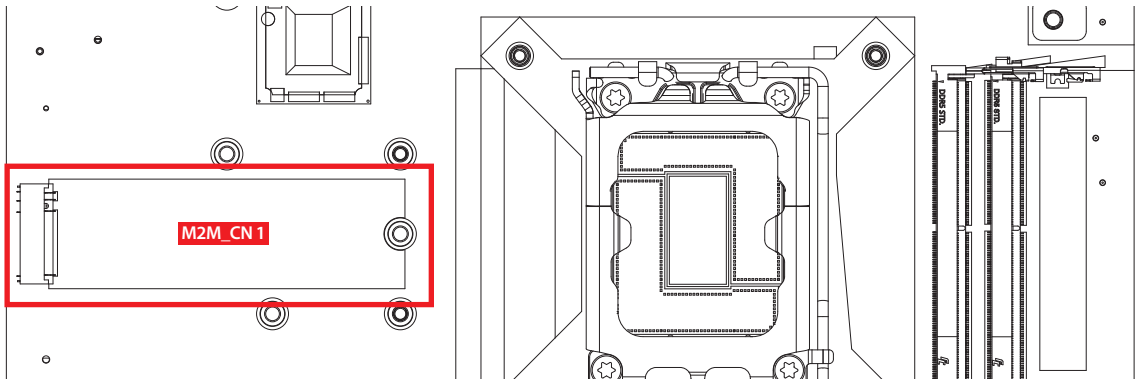

M2M\_CN1 : M.2 KEY M (Dimension : 2280)

| Pin No.        | Signal Name   | Pin No. | Signal Name |
|----------------|---------------|---------|-------------|
| 75             | Ground        |         |             |
| 73             | Ground        | 74      | 3.3V        |
| 71             | Ground        | 72      | 3.3V        |
| 69             | PEDET         | 70      | 3.3V        |
| 67             | Ground        | 68      | NC          |
| Mechanical Key |               |         |             |
| 57             | Ground        | 58      | NC          |
| 55             | REFCLKp       | 56      | NC          |
| 53             | REFCLKn       | 54      | PEWAKE#     |
| 51             | Ground        | 52      | CLKREQ#     |
| 49             | PETp0/SATA_A+ | 50      | PERST#      |
| 47             | PETn0/SATA_A- | 48      | NC          |
| 45             | Ground        | 46      | NC          |
| 43             | PERp0/SATA_B- | 44      | NC          |
| 41             | PERn0/SATA_B+ | 42      | NC          |
| 39             | Ground        | 40      | NC          |
| 37             | PETp1         | 38      | DEVSLP      |
| 35             | PETn1         | 36      | NC          |
| 33             | Ground        | 34      | NC          |
| 31             | PERp1         | 32      | NC          |
| 29             | PERn1         | 30      | NC          |
| 27             | Ground        | 28      | NC          |



| Pin No. | Signal Name | Pin No. | Signal Name |
|---------|-------------|---------|-------------|
| 25      | PETp2       | 26      | NC          |
| 23      | PETn2       | 24      | NC          |
| 21      | Ground      | 22      | NC          |
| 19      | PERp2       | 20      | NC          |
| 17      | PERn2       | 18      | 3.3V        |
| 15      | Ground      | 16      | 3.3V        |
| 13      | PETp3       | 14      | 3.3V        |
| 11      | PETn3       | 12      | 3.3V        |
| 9       | Ground      | 10      | LED1#       |
| 7       | PERp3       | 8       | NC          |
| 5       | PERn3       | 6       | NC          |
| 3       | Ground      | 4       | 3.3V        |
| 1       | Ground      | 2       | 3.3V        |

#### 2.4.15 M2E\_CN1 : USB2.0/2x PCIe1

M.2 key E connector is suitable for applications that use wireless connectivity including Wi-Fi, Bluetooth, NFC or GNSS. Module card types include 2230.

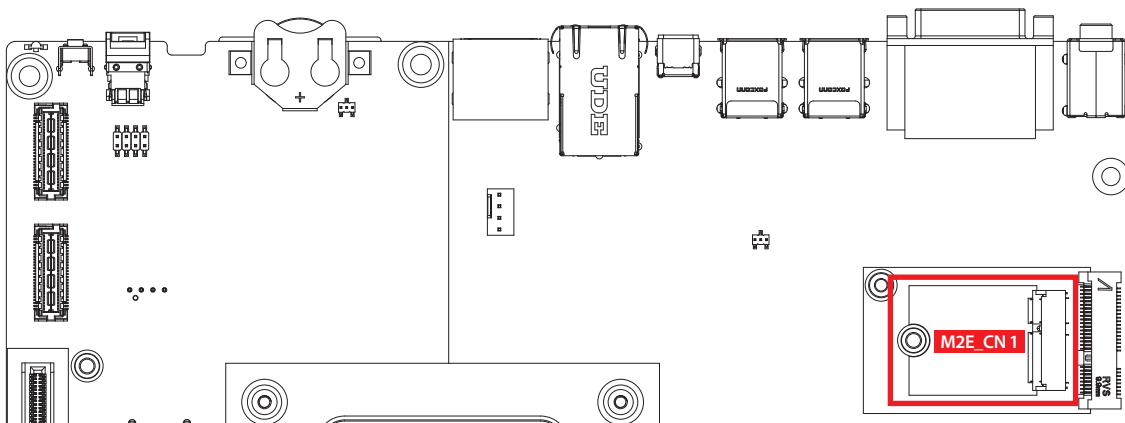

M2E\_CN1 : M.2 KEY E (Dimension : 2230)

| Pin No. | Signal Name | Pin No. | Signal Name |
|---------|-------------|---------|-------------|
| 75      | Ground      |         |             |
| 73      | NC          | 74      | 3.3V        |
| 71      | NC          | 72      | 3.3V        |
| 69      | Ground      | 70      | PEWAKE1#    |
| 67      | NC          | 68      | NC          |
| 65      | NC          | 66      | NC          |

| Pin No.        | Signal Name | Pin No. | Signal Name |
|----------------|-------------|---------|-------------|
| 63             | Ground      | 64      | NC          |
| 61             | NC          | 62      | ALERT       |
| 59             | NC          | 60      | I2C_CLK     |
| 57             | Ground      | 58      | I2C_DATA    |
| 55             | PEWAKE0#    | 56      | NC          |
| 53             | CLKREQ0#    | 54      | NC          |
| 51             | Ground      | 52      | PERST0#     |
| 49             | REFCLKn0    | 50      | NC          |
| 47             | REFCLKp0    | 48      | NC          |
| 45             | Ground      | 46      | NC          |
| 43             | PERn0       | 44      | NC          |
| 41             | PERp0       | 42      | NC          |
| 39             | Ground      | 40      | NC          |
| 37             | PETn0       | 38      | DEVSLP      |
| 35             | PETp0       | 36      | NC          |
| 33             | Ground      | 34      | NC          |
|                |             | 32      | NC          |
| Mechanical Key |             |         |             |
| 23             | NC          |         |             |
| 21             | NC          | 22      | NC          |
| 19             | Ground      | 20      | NC          |
| 17             | NC          | 18      | Ground      |
| 15             | NC          | 16      | NC          |
| 13             | Ground      | 14      | NC          |
| 11             | NC          | 12      | NC          |
| 9              | NC          | 10      | NC          |
| 7              | Ground      | 8       | NC          |
| 5              | USB-        | 6       | LED1#       |
| 3              | USB+        | 4       | 3.3V        |
| 1              | Ground      | 2       | 3.3V        |

## 2.4.16 JCOM1,JCOM2,JCOM3,JCOM4 : Serial Port cable Connector

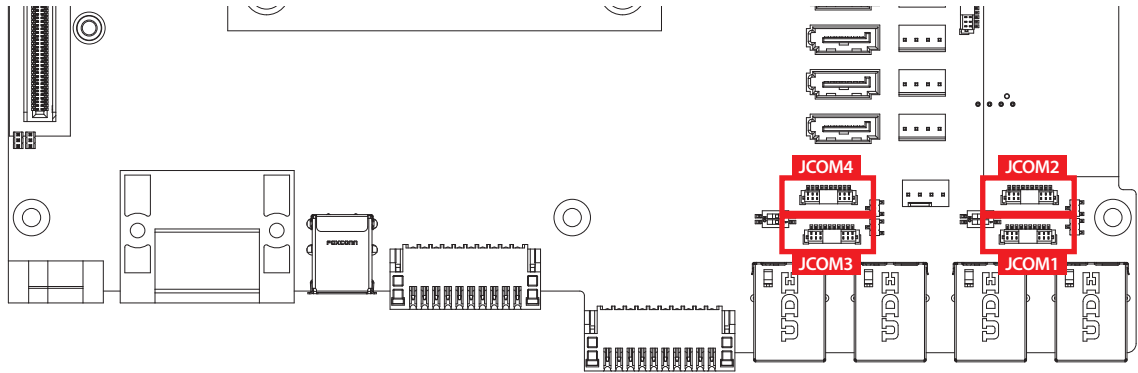

| Location | Description |
|----------|-------------|
| JCOM1    | COM1        |
| JCOM2    | COM2        |
| JCOM3    | COM3        |
| JCOM4    | COM4        |

| Pin No. | Function |
|---------|----------|
| 1       | NC       |
| 2       | GND      |
| 3       | RI       |
| 4       | DTR      |
| 5       | CTS      |
| 6       | TXD      |
| 7       | RTS      |
| 8       | RXD      |
| 9       | DSR      |
| 10      | DCD      |

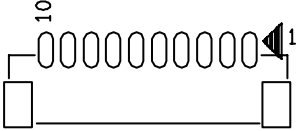

### 2.4.17 JIGN\_FW1 : IGNITION FW Programming Header

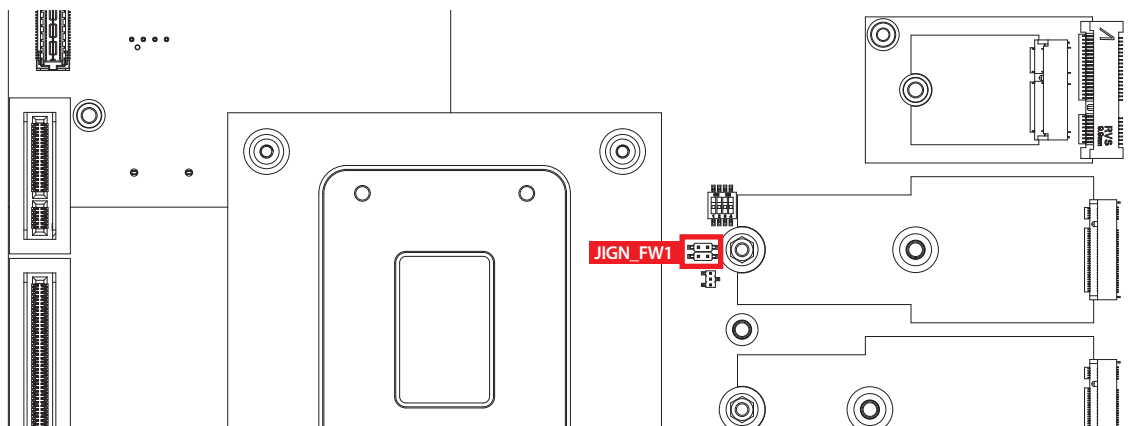

| Pin No. | Description |
|---------|-------------|
| 1       | GND         |
| 2       | MCU_RST#    |
| 3       | +V3.3_MCU   |
| 4       | MCU_PRG     |

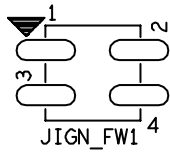

## 2.4.18 Graphic Card Power Connector

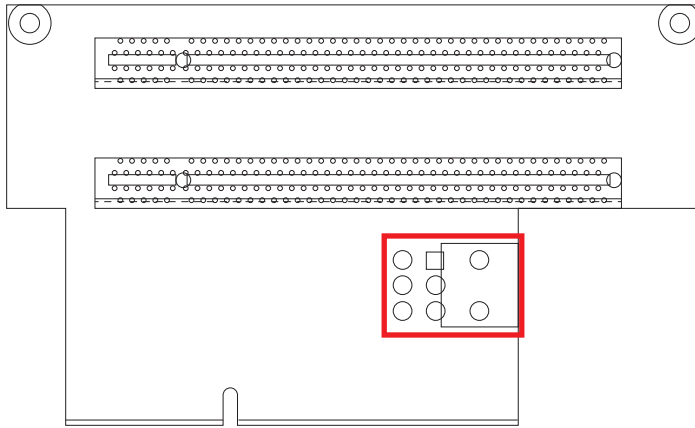

| Pin No. | Definition |
|---------|------------|
| 1       | +12V       |
| 2       | GND        |
| 3       | +12V       |
| 4       | GND        |
| 5       | +12V       |
| 6       | GND        |

## 2.5 Main Board Jumper Settings

### 2.5.1 Board top view of the system main board with jumper and DIP switch

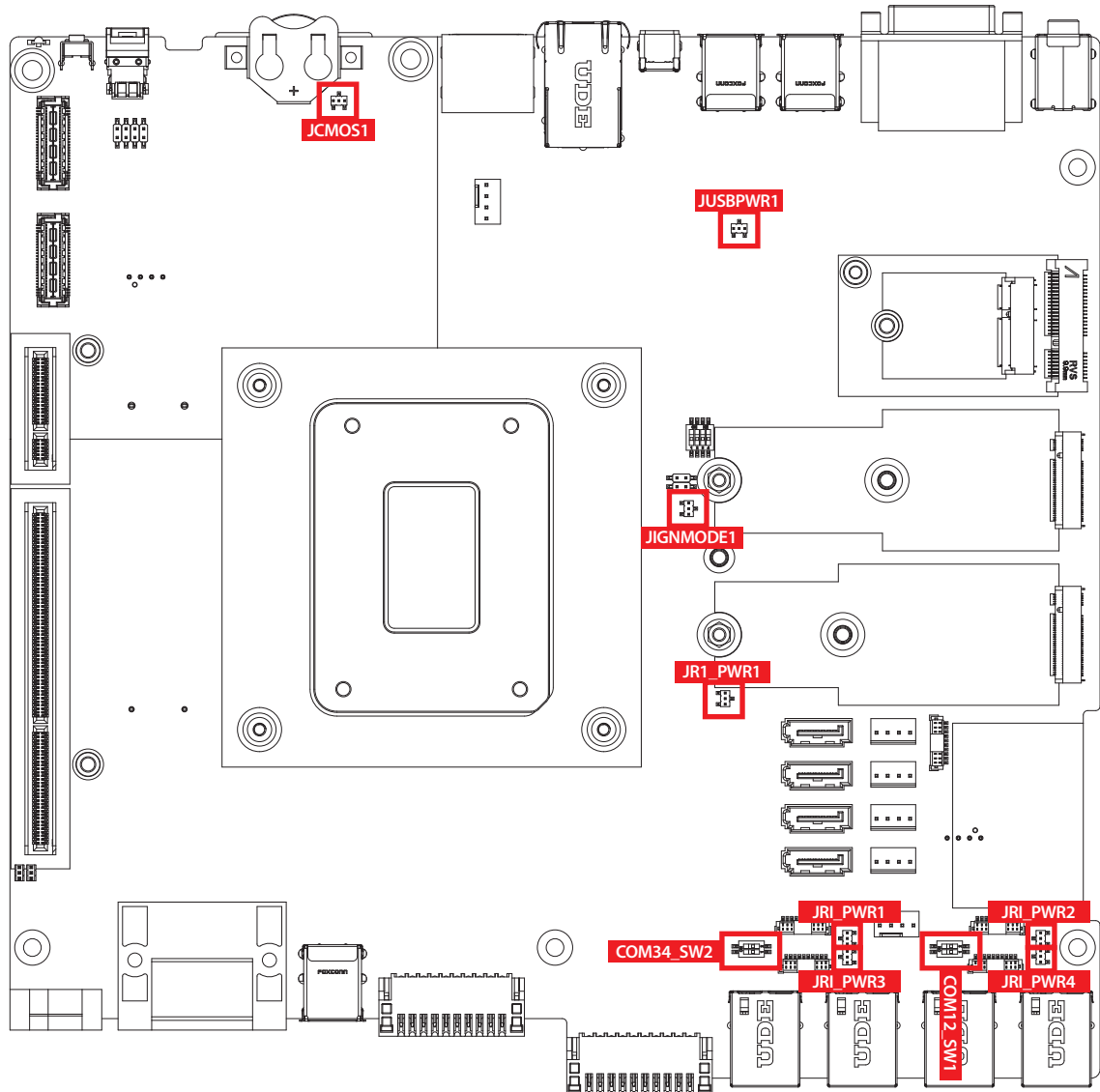

The figure below is the top view of the system main board which is the main board. It shows the location of the jumpers and the switches.

You may configure your card to match the needs of your application by setting jumpers. A jumper is a metal bridge used to close an electric circuit. It consists of two metal pins and a small metal clip (often protected by a plastic cover) that slides over the pins to connect them. To “close” a jumper, you connect the pins with the clip. To “open” a jumper, you remove the clip. Sometimes a jumper will have three pins, labeled 1, 2 and 3. In this case you would connect either pins 1 and 2, or 2 and 3.

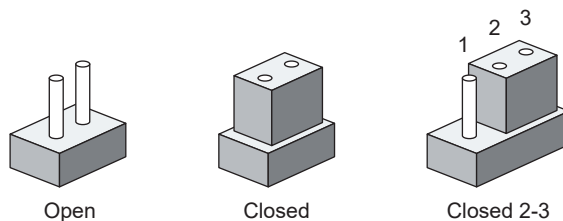

You may configure your card to match the needs of your application by DIP switch. As below show the DIP switch on and off.

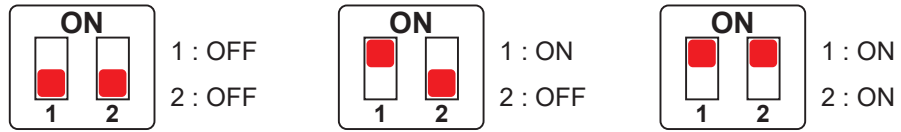

### 2.5.2 JUSBPWR1 : USB Wake Up

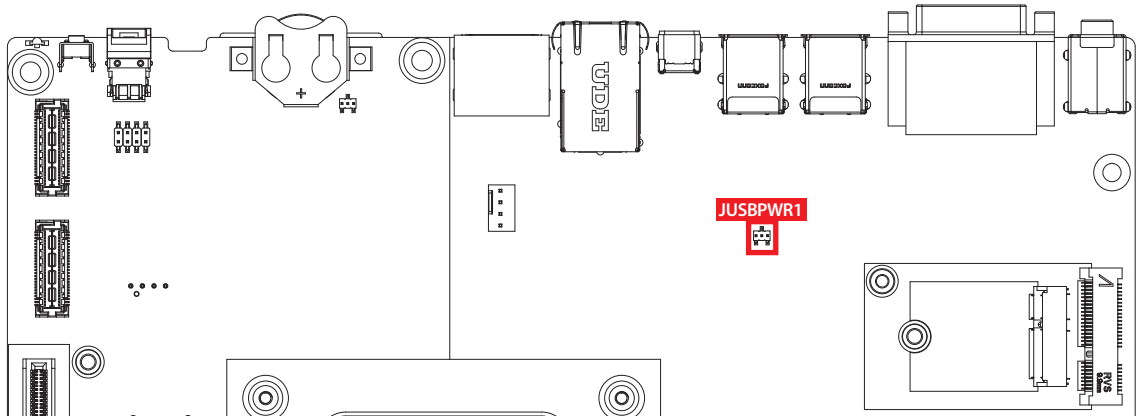

| Location | Description | Function                   |
|----------|-------------|----------------------------|
| JUSBPWR1 | 2 - 3       | Non Wake Up support        |
|          | 1 - 2       | Supported Wake Up(Default) |

Front Plane View

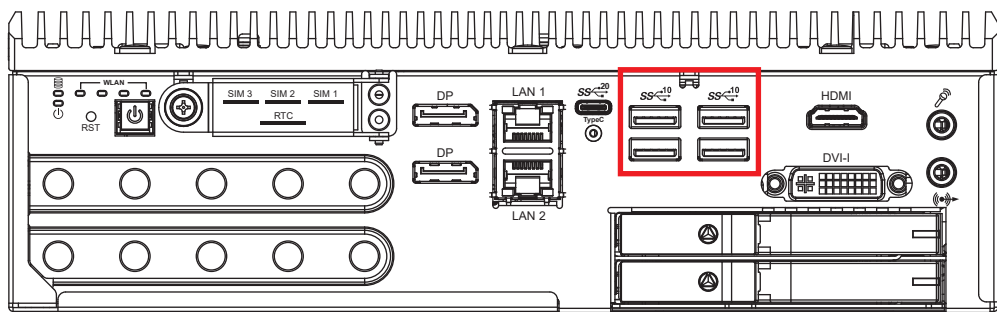

Rear Plane View

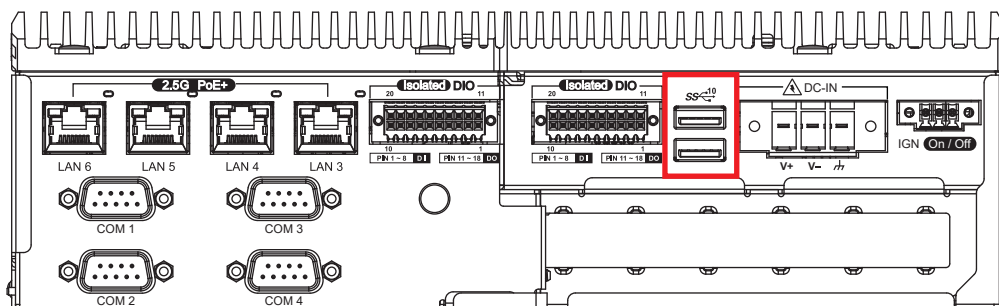

### 2.5.3 JRI\_PWR1,JRI\_PWR2, JRI\_PWR3, JRI\_PWR4 : COM Port RI pin Select

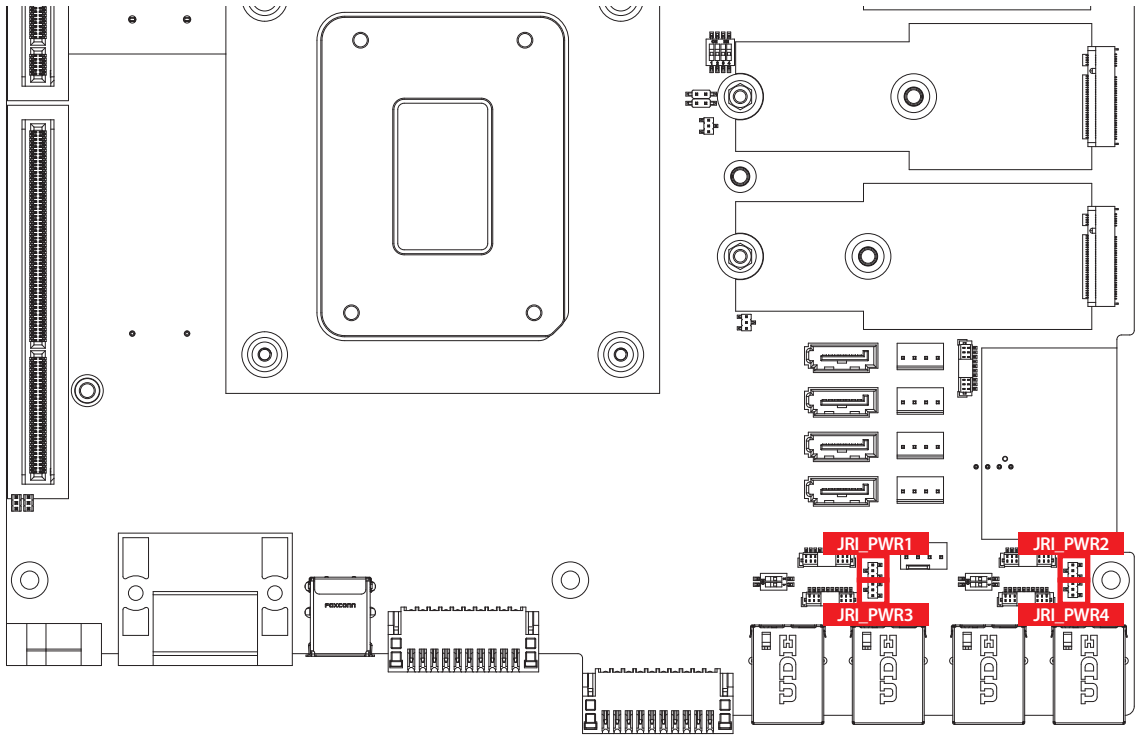

| Location | Pin Number | Description      | COM Port |
|----------|------------|------------------|----------|
| JRI_PWR1 | 1 - 2      | +12V (0.5A max.) | COM1     |
|          | 2 - 3      | RI(Default)      |          |
| JRI_PWR2 | 1 - 2      | +12V (0.5A max.) | COM2     |
|          | 2 - 3      | RI(Default)      |          |
| JRI_PWR3 | 1 - 2      | +12V (0.5A max.) | COM3     |
|          | 2 - 3      | RI(Default)      |          |
| JRI_PWR4 | 1 - 2      | +12V (0.5A max.) | COM4     |
|          | 2 - 3      | RI(Default)      |          |

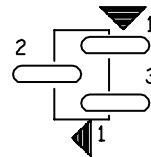



## 2.5.4 JPOE\_PWR1 : PoE Power ON Select

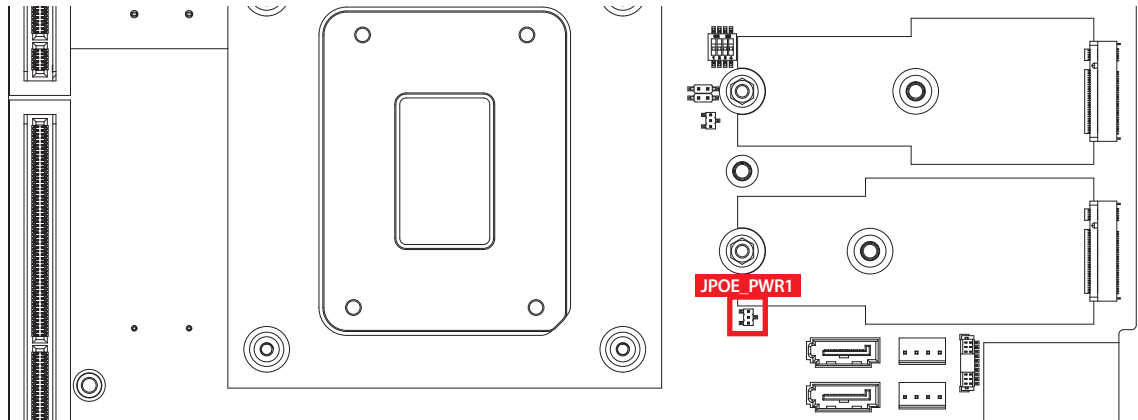

| Location  | Description | Function                                    |  |
|-----------|-------------|---|--|
| JPOE_PWR1 | 1 - 2       | PoE power on at standby power ready         |  |
|           | 2 - 3       | PoE power on after system power on(Default) |  |
|           | No Jumper   | Disable PoE power                           |  |

## 2.5.5 JCMOS1 : Clear CMOS

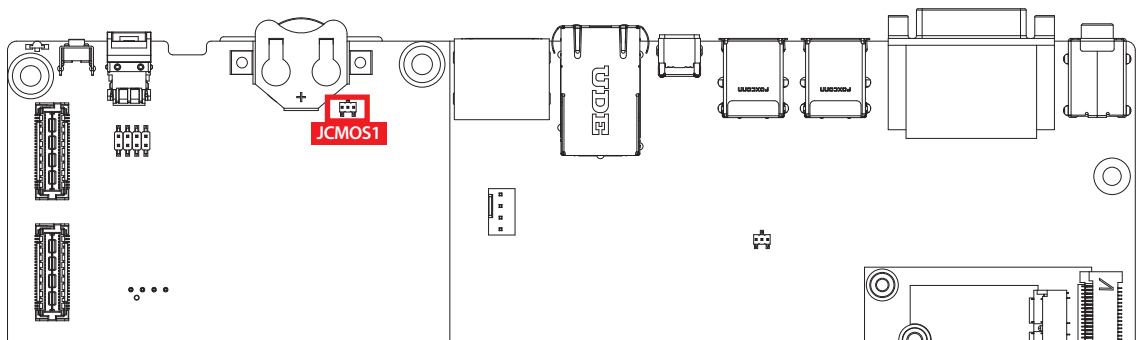

| Location | Description | Function          |  |
|----------|-------------|-------------------|--|
| JCMOS1   | 1 - 2       | *Normal (Default) |  |
|          | 2 - 3       | Clear CMOS        |  |

## 2.5.6 JP1, JP2 : PCI Express\* Configuration

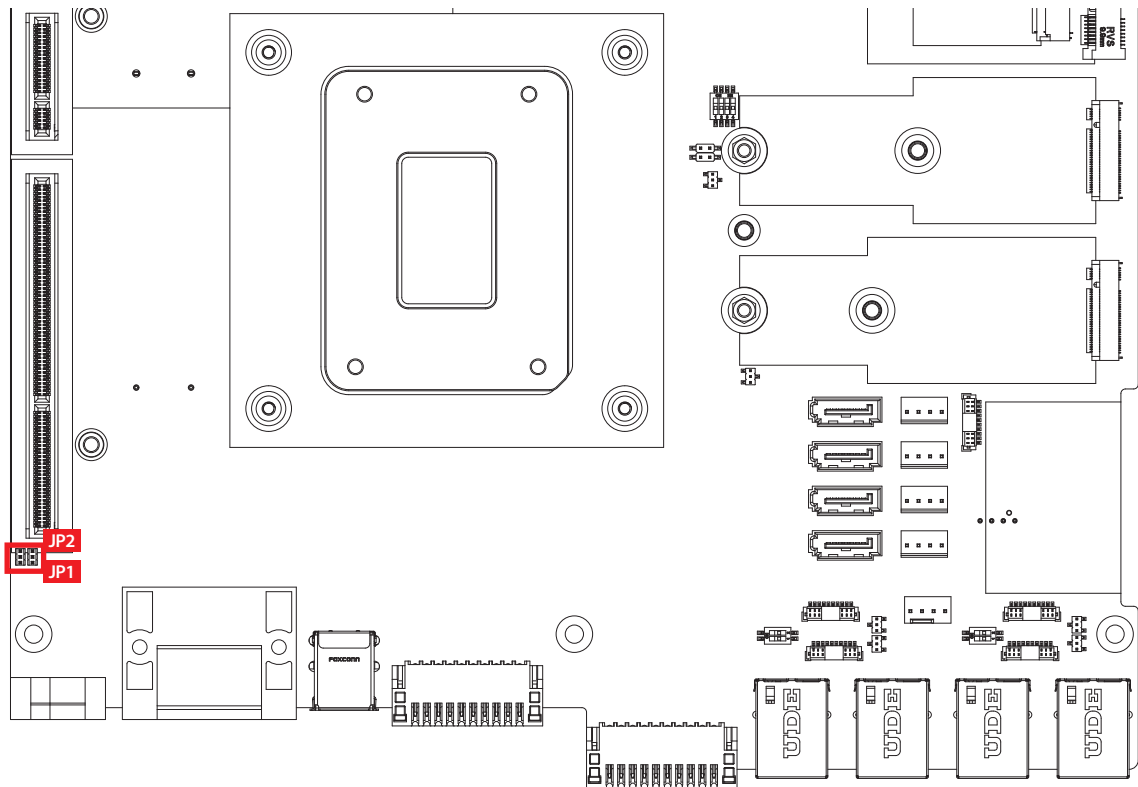

JP1, JP2 provide PCIe slot (CN59) configuration function, Closing Pin 1 and Pin 2 is logic "0". Closing Pin 2 and Pin 3 is logic "1".

JP1, JP2 logic setting are listed in the following table.

| JP1 | Logic |
|-----|-------|
| 1-2 | 0     |
| 2-3 | 1     |

| JP2 | Logic |
|-----|-------|
| 1-2 | 0     |
| 2-3 | 1     |

JP1, JP2 PCI Express configurations are listed in the following table.

| JP2 | JP1 | PCI Express* Bifurcation |
|-----|-----|--------------------------|
| 0   | 0   | 1 x8 PCI Express*        |
| 1   | 0   | 2 x8 PCI Express*        |
| 1   | 1   | 1 x16 PCI Express*       |

## 2.5.7 JIGNMODE1 : IGNITION Mode

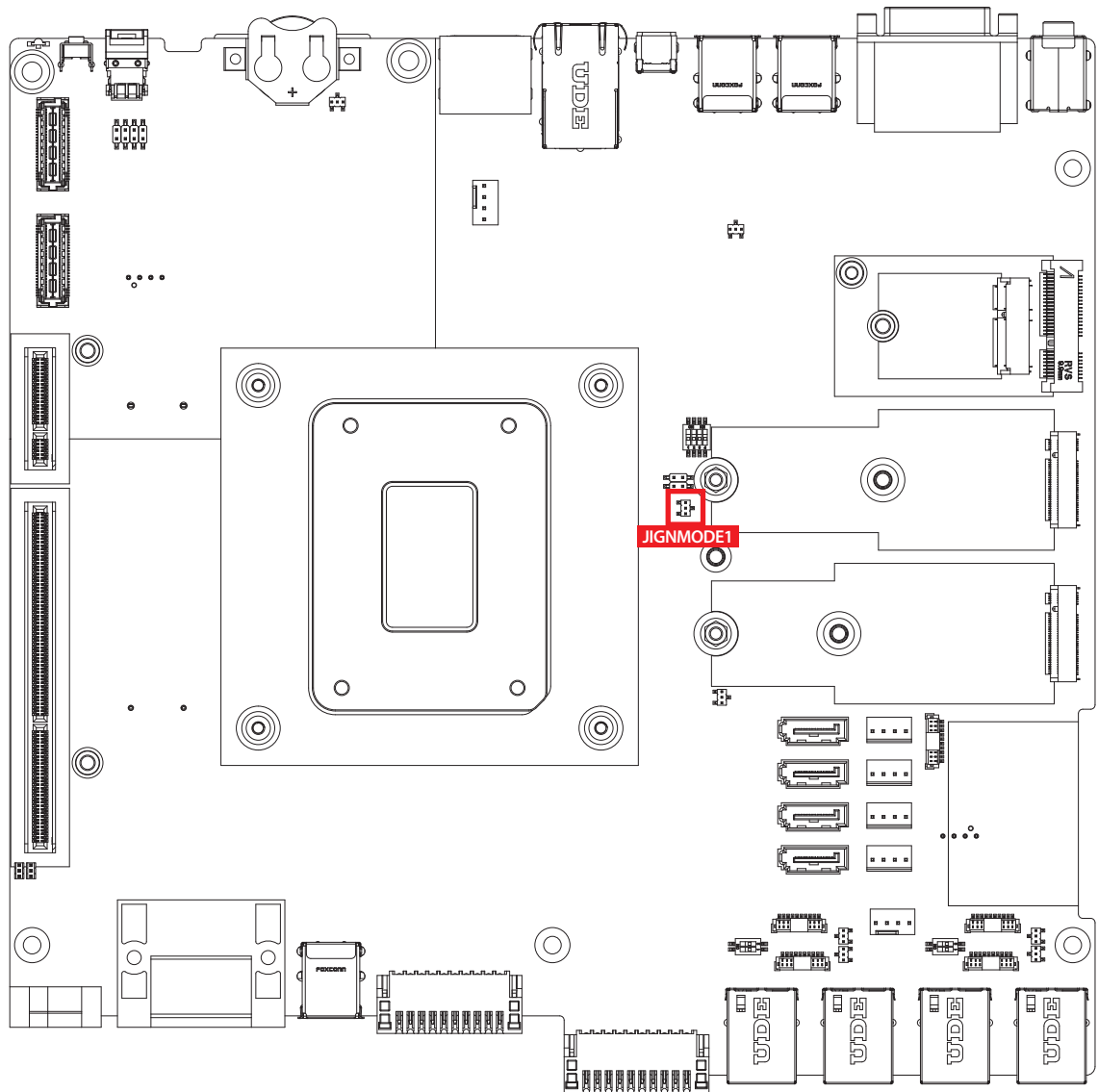

| Location  | Description | Function          |  |
|-----------|-------------|-------------------|--|
| JIGNMODE1 | 1 - 2       | H/W mode          |  |
|           | 2 - 3       | S/W mode(default) |  |

## 2.5.8 COM12\_120R\_SW1,COM34\_120R\_SW1 : RS-485/422 RECEIVER TERMINATION RESISTANCE

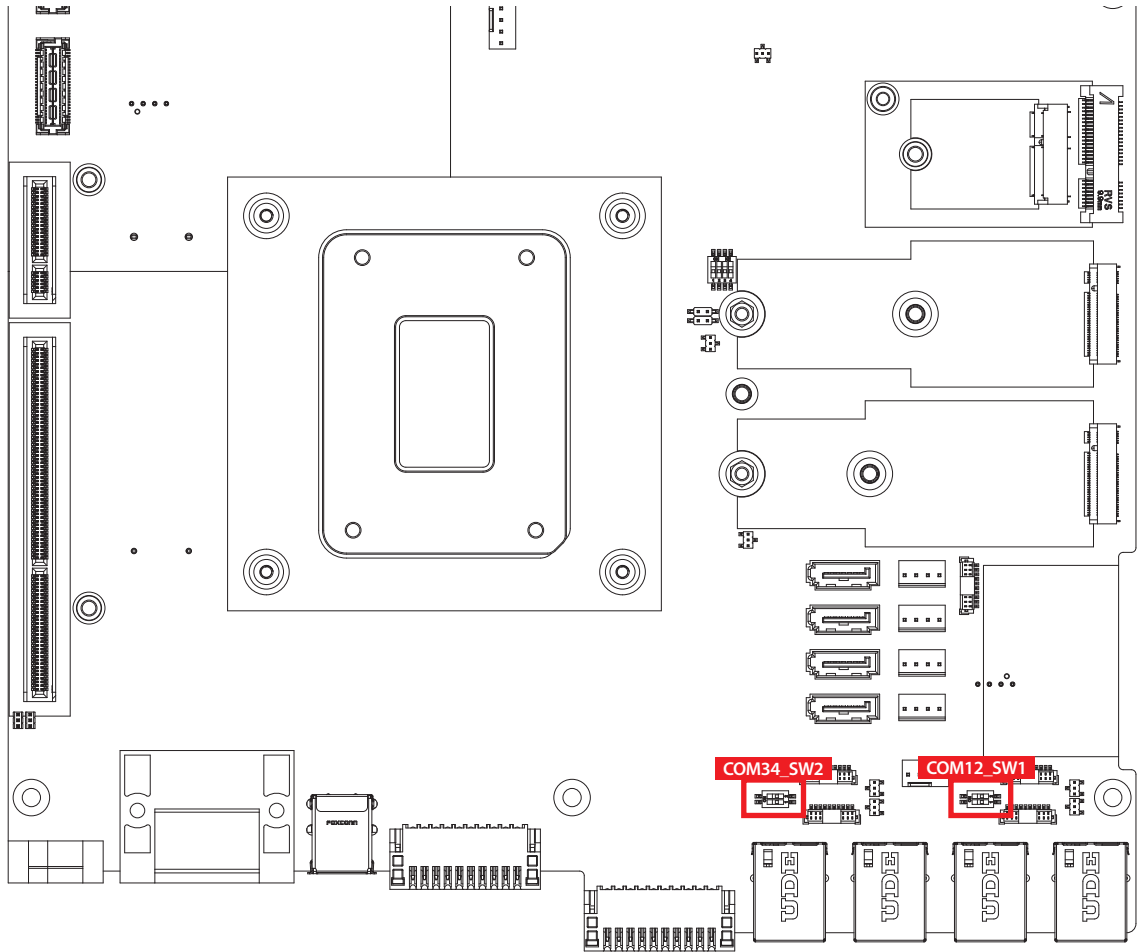

| JP2            | Setting | Function                                    | Port |
|----------------|---------|---|------|
| COM12_120R_SW1 | 1(ON)   | DCD / RXD Termination 120R enable           | COM1 |
|                | 1(OFF)  | DCD / RXD Termination 120R Disable(default) |      |
|                | 2(ON)   | DCD / RXD Termination 120R enable           | COM2 |
|                | 2(OFF)  | DCD / RXD Termination 120R Disable(default) |      |
| COM34_120R_SW1 | 1(ON)   | DCD / RXD Termination 120R enable           | COM1 |
|                | 1(OFF)  | DCD / RXD Termination 120R Disable(default) |      |
|                | 2(ON)   | DCD / RXD Termination 120R enable           | COM2 |
|                | 2(OFF)  | DCD / RXD Termination 120R Disable(default) |      |

## 2.6 Ignition Control

ECX-3000 PEG provides ignition power control feature for in-vehicle applications. The built-in MCU monitors the ignition signal and turns on/off the system according to pre-defined on/off delay period.



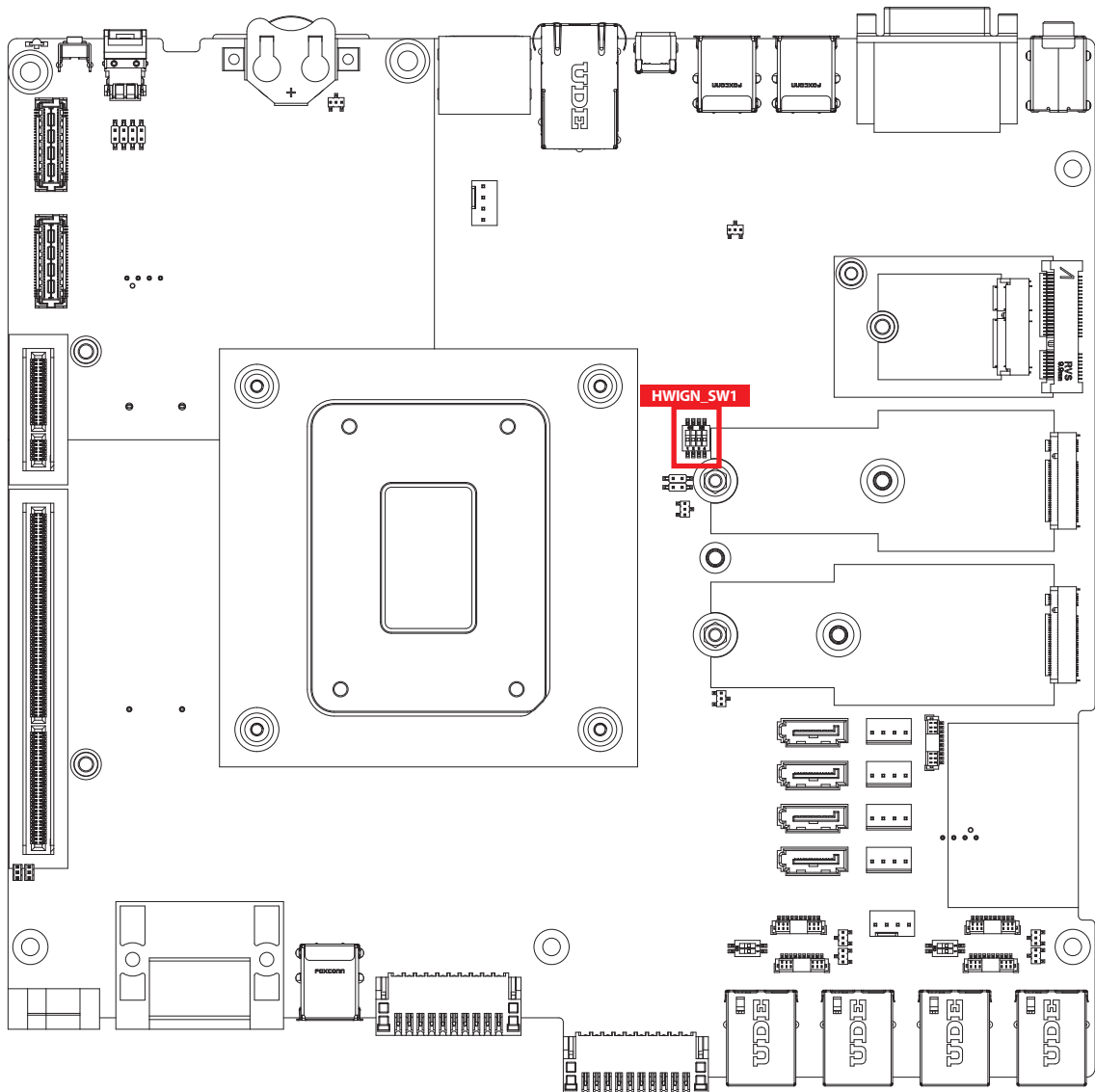

### 2.6.1 Adjust Ignition Control Modes

ECX-3000 PEG provides 16 modes of different power on/off delay periods adjustable via SW2 switch. The default rotary switch is set to 0 in ATX/AT power mode.

HWIGN\_SW1 : Ignition Control

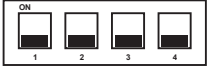

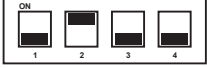
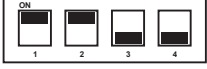
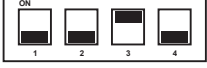
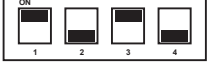
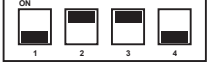
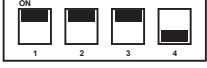
The modes are listed in below table :

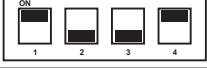
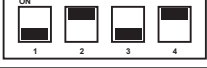
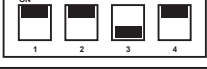
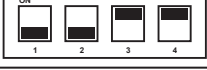
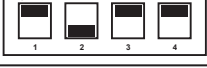
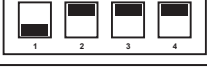
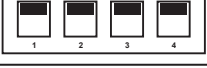
| DIP Switch Position | Power on delay        | Power off delay | Switch Position   |
|---------------------|-----------------------|-----------------|---|
| 0                   | ATX/AT mode (Default) |                 |    |
| 1                   | No delay              | No delay        |    |
| 2                   | No delay              | 5 seconds       |    |
| 3                   | No delay              | 10 seconds      |    |
| 4                   | No delay              | 30 seconds      |    |
| 5                   | No delay              | 60 seconds      |    |
| 6                   | 5 seconds             | 10 seconds      |    |
| 7                   | 5 seconds             | 30 seconds      |   |
| 8                   | 5 seconds             | 60 seconds      |  |
| 9                   | 5 seconds             | 90 seconds      |  |
| A                   | 5 seconds             | 120 seconds     |  |
| B                   | 10 seconds            | 10 seconds      |  |
| C                   | 10 seconds            | 30 seconds      |  |
| D                   | 10 seconds            | 60 seconds      |  |
| E                   | 10 seconds            | 90 seconds      |  |
| F                   | 10 seconds            | 120 seconds     |  |

## 2.6.2 Ignition Control Wiring

To activate ignition control, you need to provide IGN signal via the 3-pin pluggable terminal block locates in the back panel. Please find below the general wiring configuration.

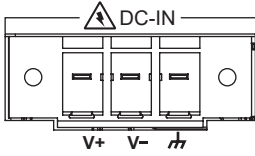

| Pin No. | Definition |
|---------|------------|
| 1       | Ignition   |
| 2       | SW+        |
| 3       | SW-        |



For testing purpose, you can refer to the picture blow to simulate ignition signal input controlled by a latching switch.

Note :

1. DC power source and IGN share the same ground.
2. ECX-3000 PEG supports 12V to 50V wide range DC power input in ATX/AT mode. In Ignition mode, the input voltage is fixed to 12V/24V for car battery scenario.
3. For proper ignition control, the power button setting should be "Power Down" mode.

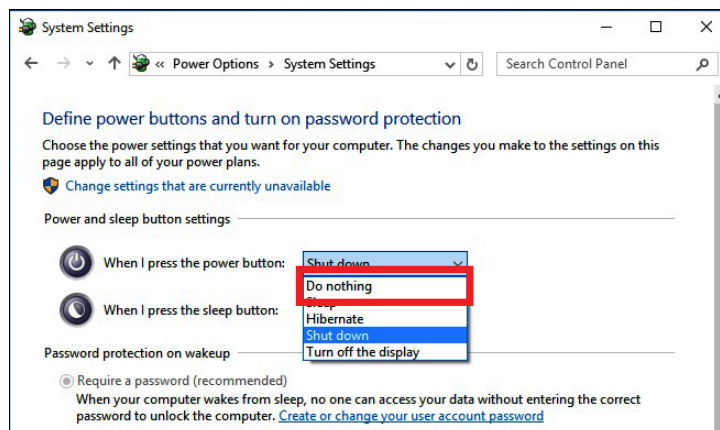

In Windows for example, you need to set "When I press the power button" to Shut down.

# 3

## SYSTEM SETUP

### 3.1 Installing CPU

**Step 1** Remove **four flat head M3x5L screws**, **four pan head SFW M3x6L screws** and **pan head SFW M2.5x6L screw**, and take out heat sink.

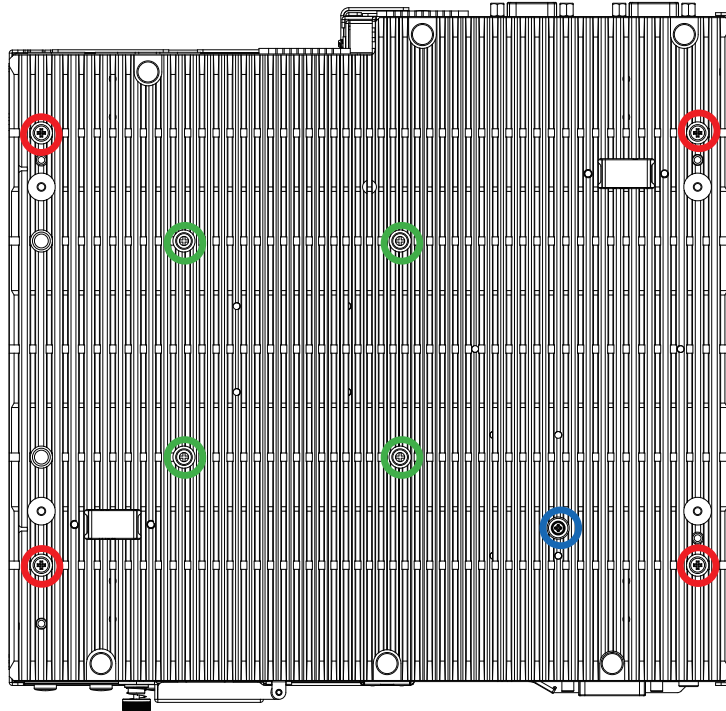



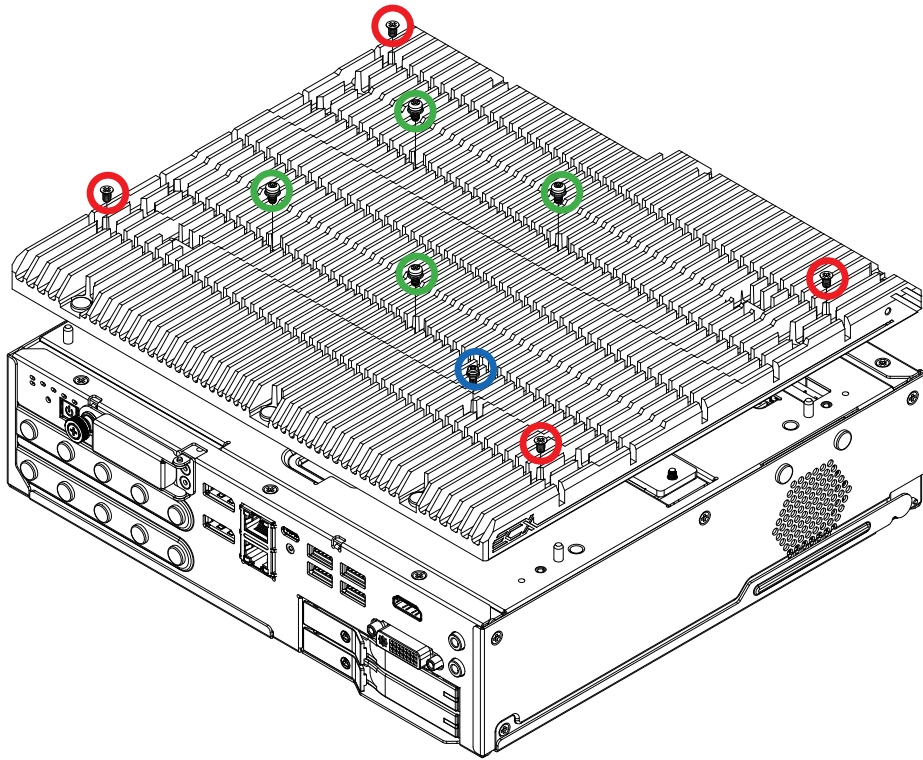

**Step 2** Take out heat sink.

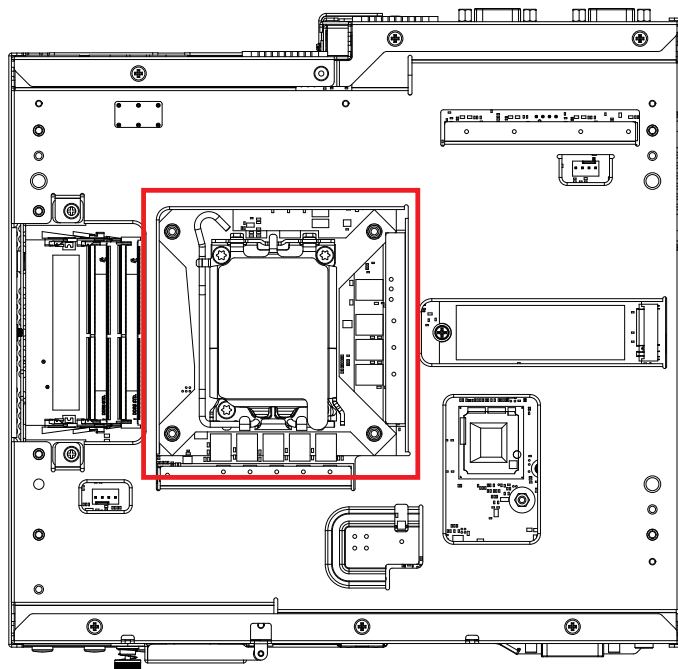

**Step 3** Remove CPU mylar

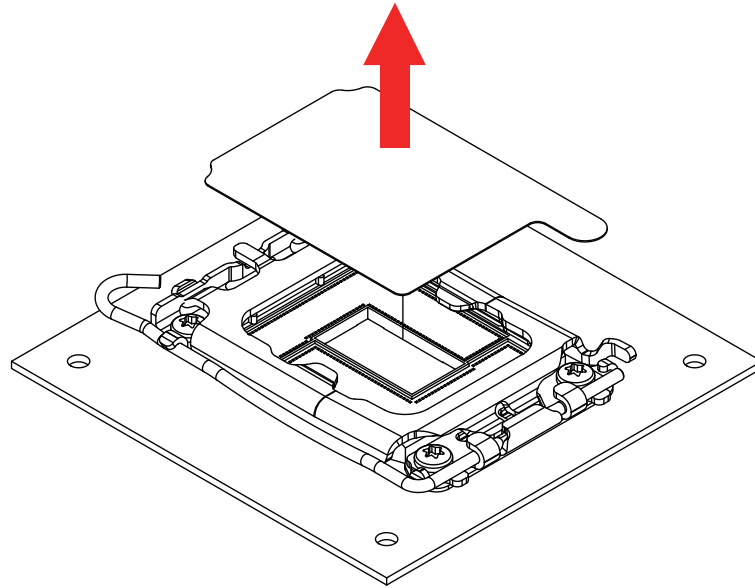

**Step 4** Open CPU independent loading mechanism (ILM)

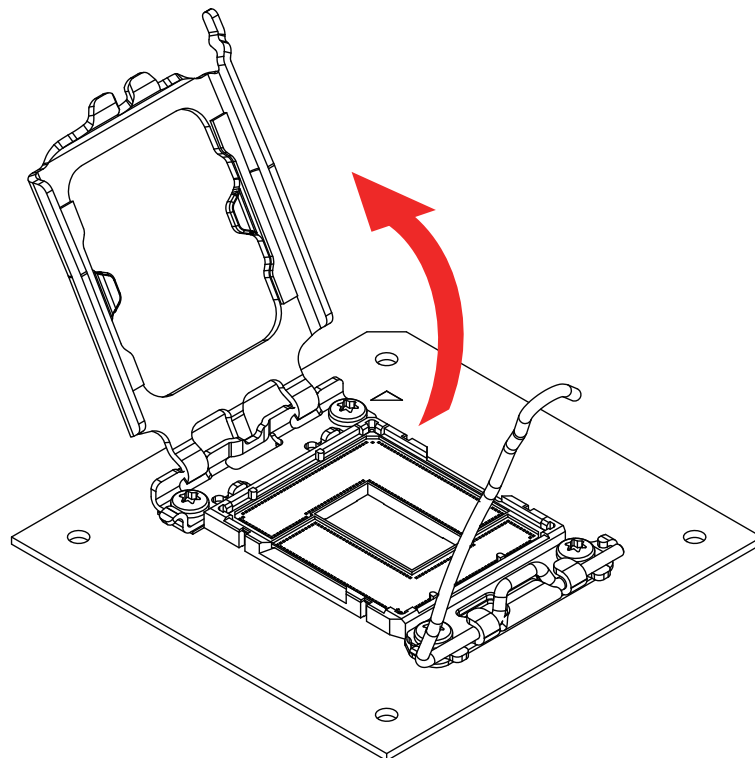

**Step 5** Install CPU. (Be careful CPU pin)

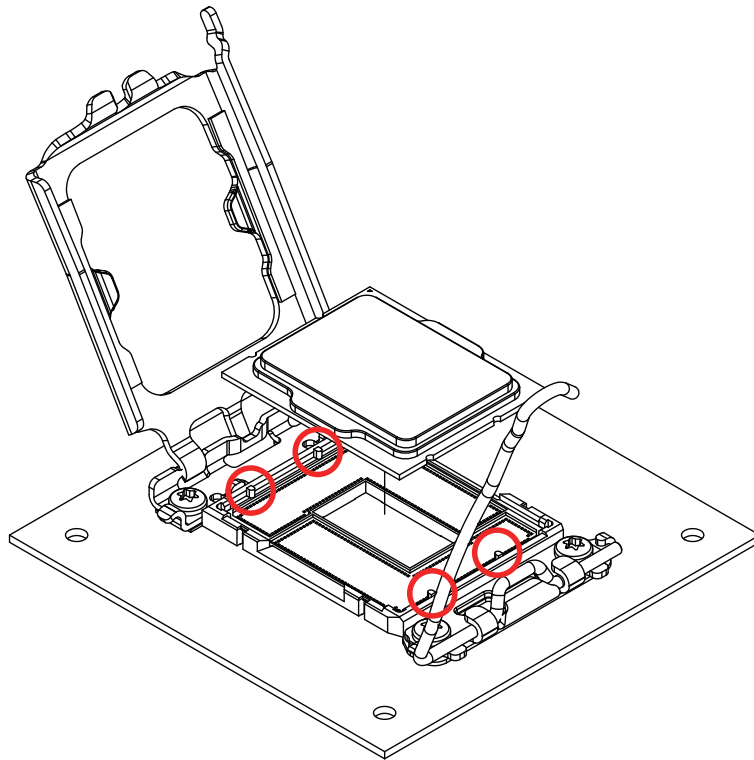

**Step 6** Close CPU independent loading Mechanism (ILM) and finish

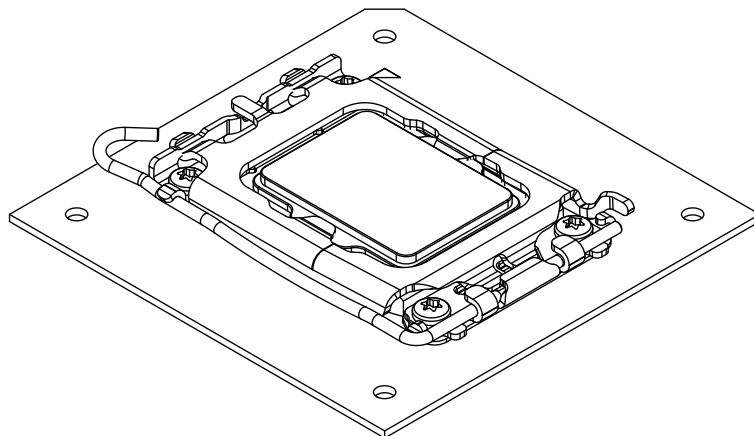

## 3.2 Installing DDR5 SO-DIMM Modules

**Step 1** Remove **four flat head M3x5L screws**, **four pan head SFW M3x6L screws** and **pan head SFW M2.5x6L screw**, and take out heat sink.

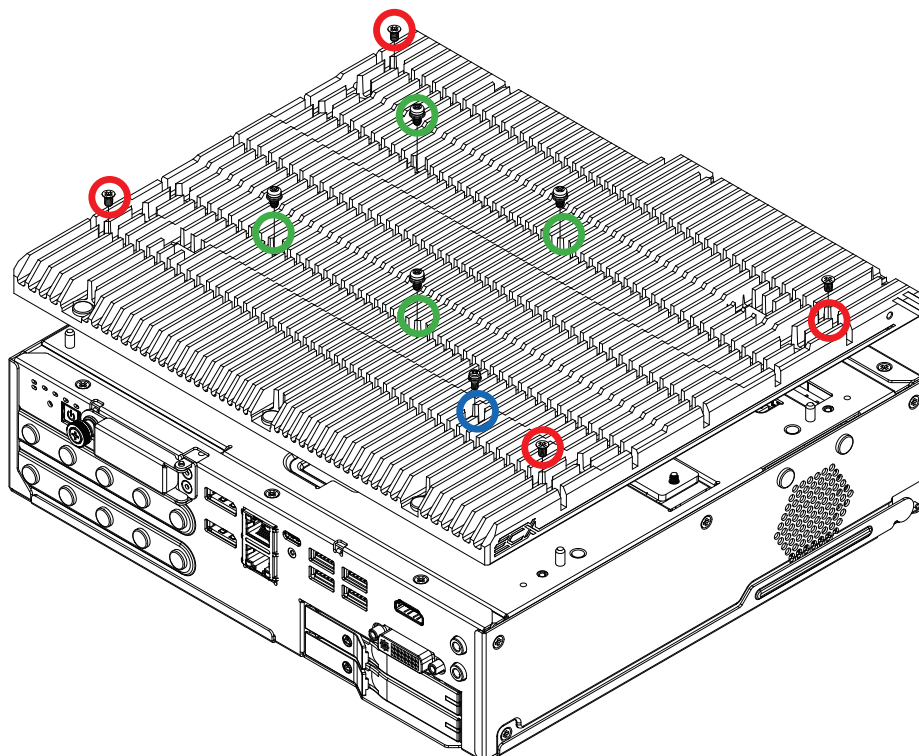
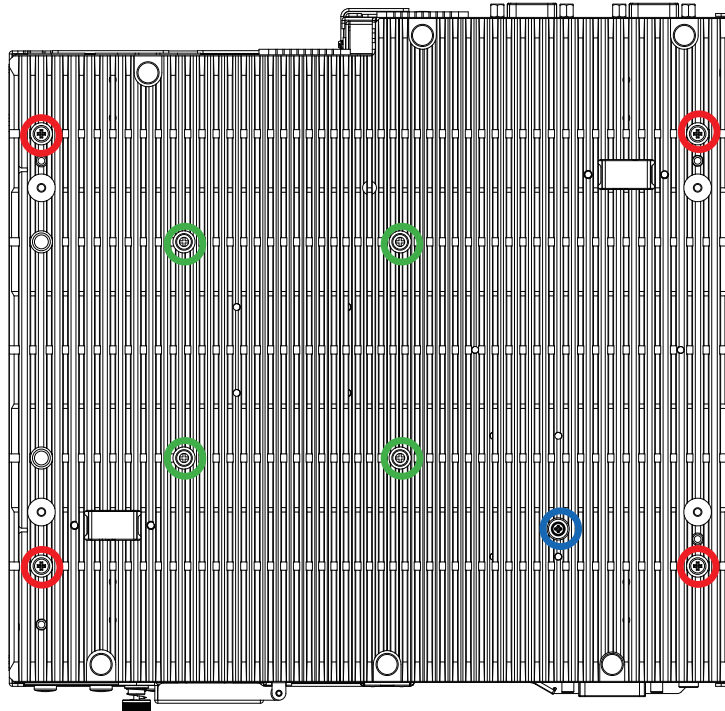

**Step 2** Take out heat sink.

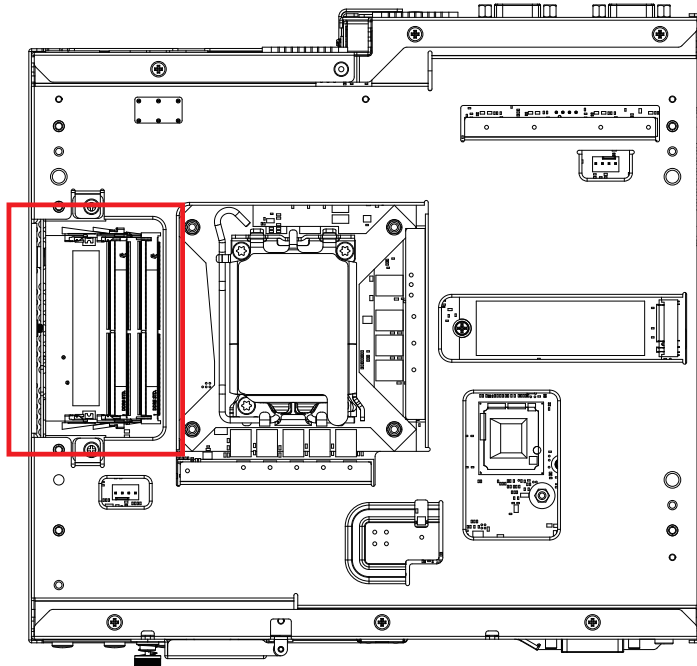

**Step 3** Install DDR5 RAM module into SO-DIMM socket



**Step 4** Make sure RAM module is locked by the memory slot



### 3.3 Installing Mini PCIe Card

Step 1 Remove four flat head M3x5L screws.

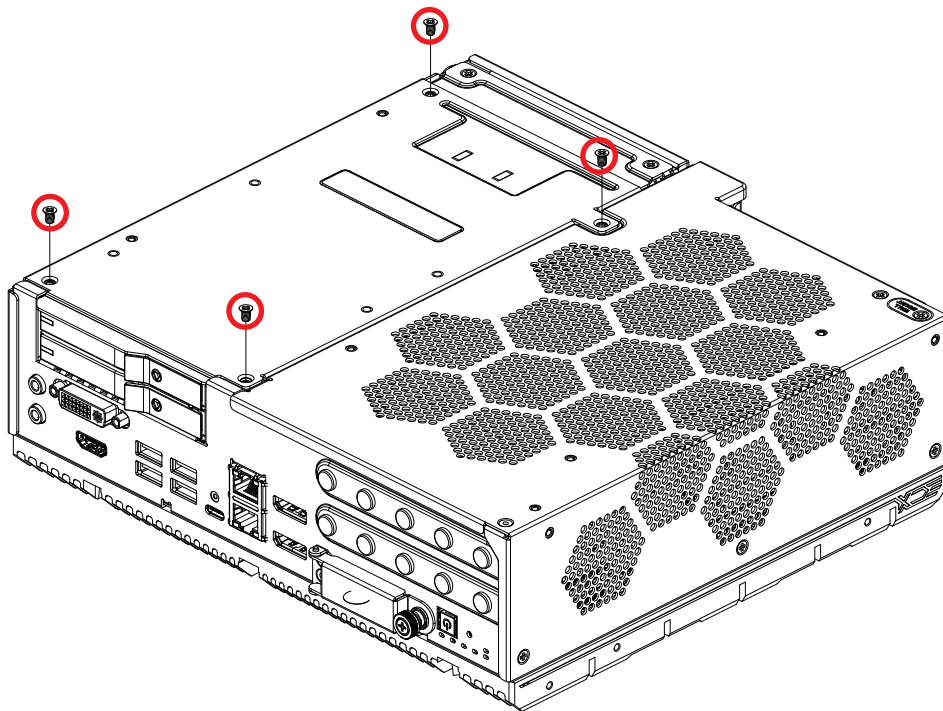
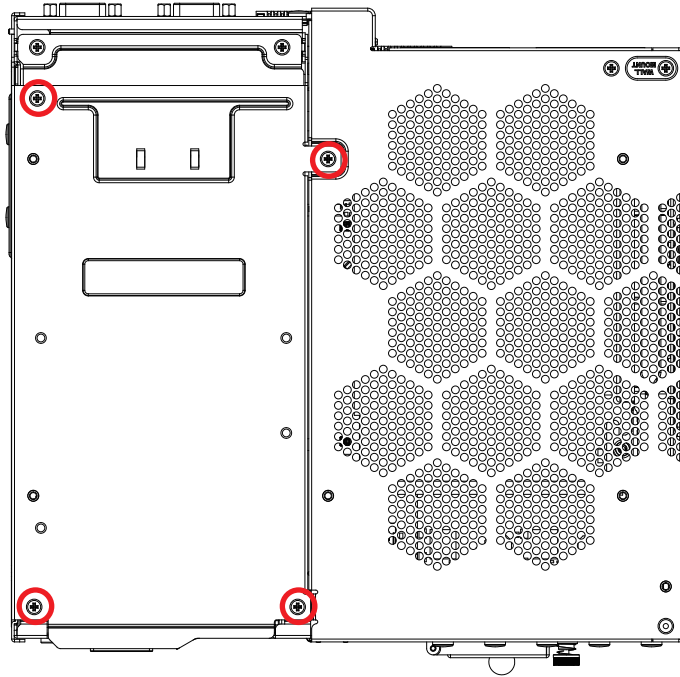

**Step 2** Open bottom cover.

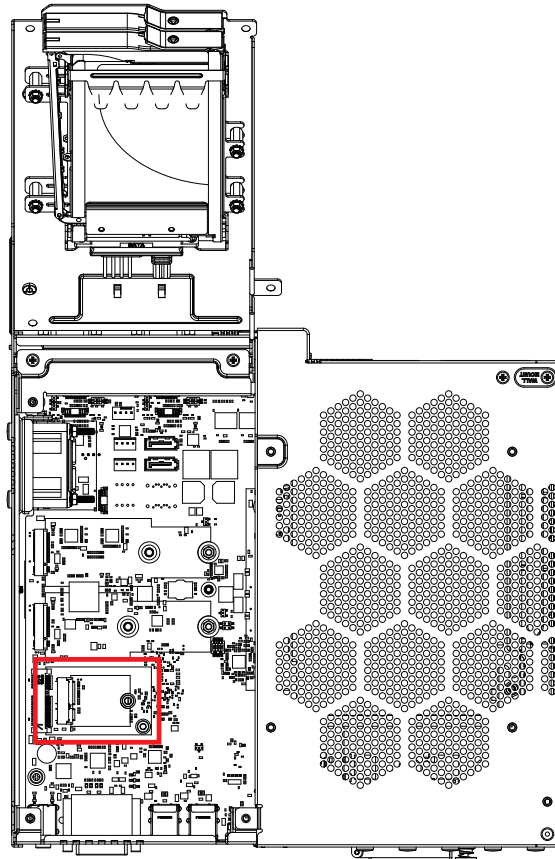
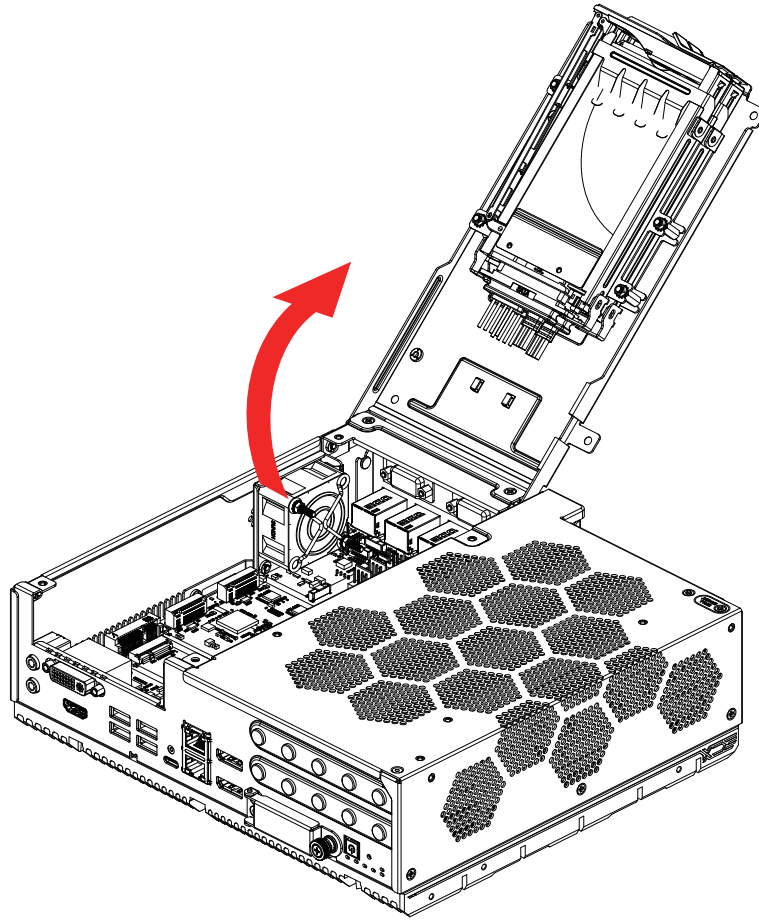



**Step 3** Install mini PCIe card into slot

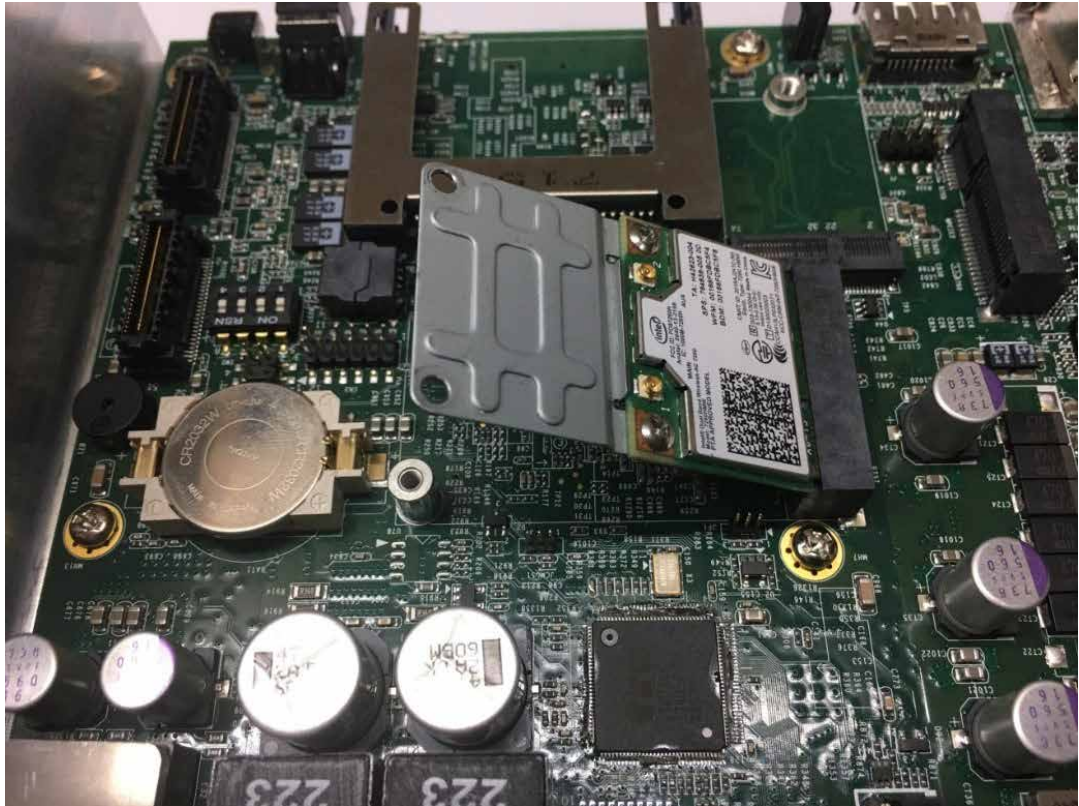

**Step 4** Fasten pan head SFW M2.5x6L screw



## 3.4 Installing Nano SIM Card

**Step 1** Release captive panel screw.

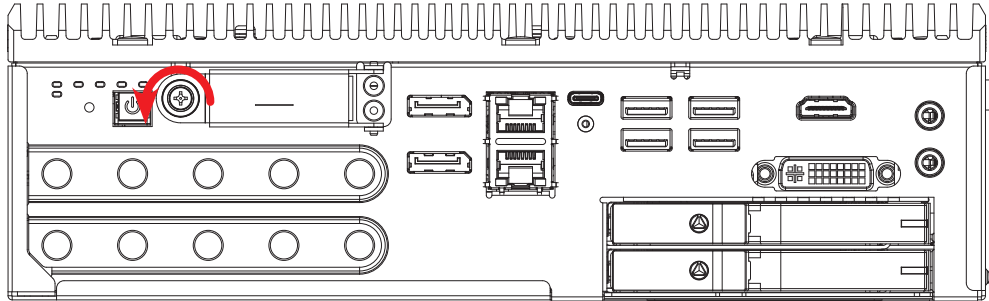

**Step 2** Open service Card.

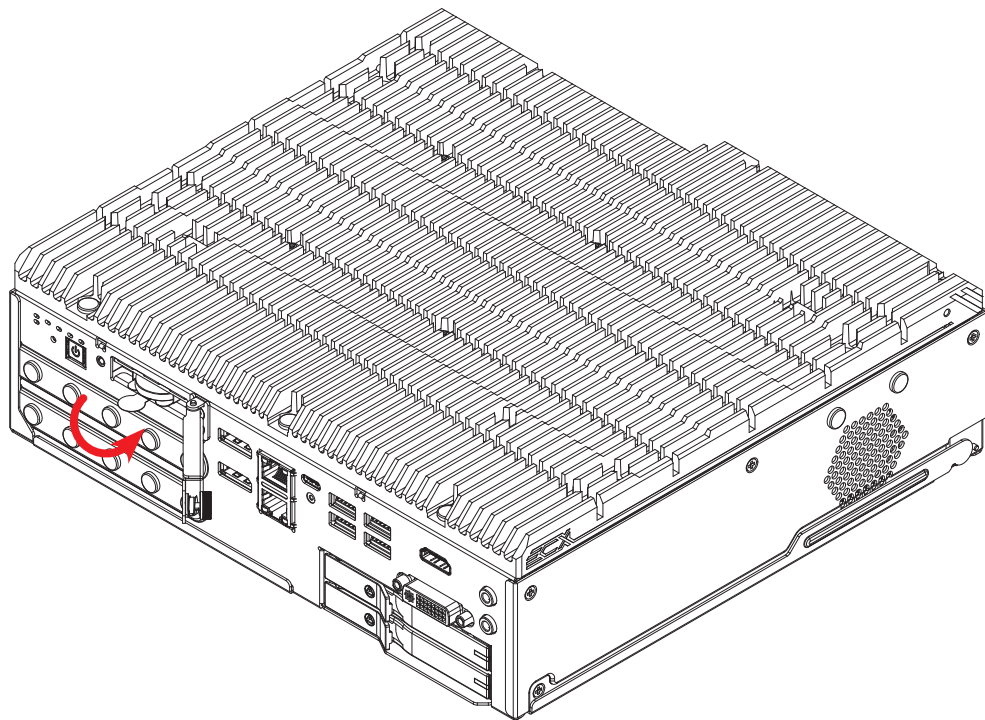

**Step 3** Insert nano SIM card and push to lock.

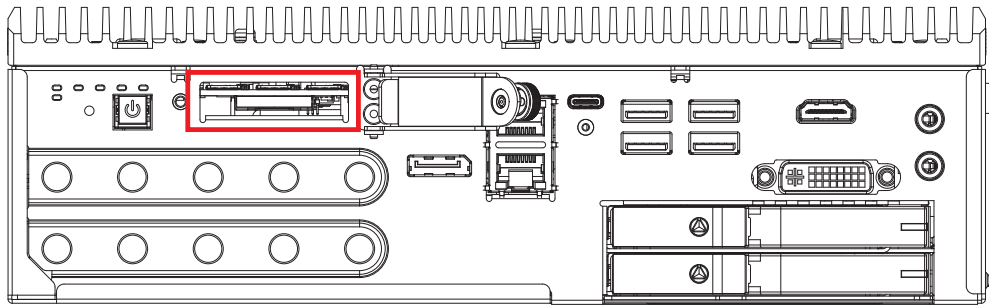

### 3.5 Installing Removable RTC Battery

**Step 1** Release captive panel screw.

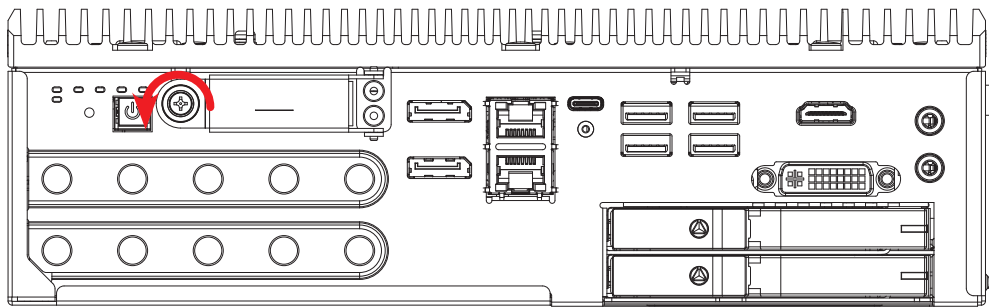

**Step 2** Open service Card.

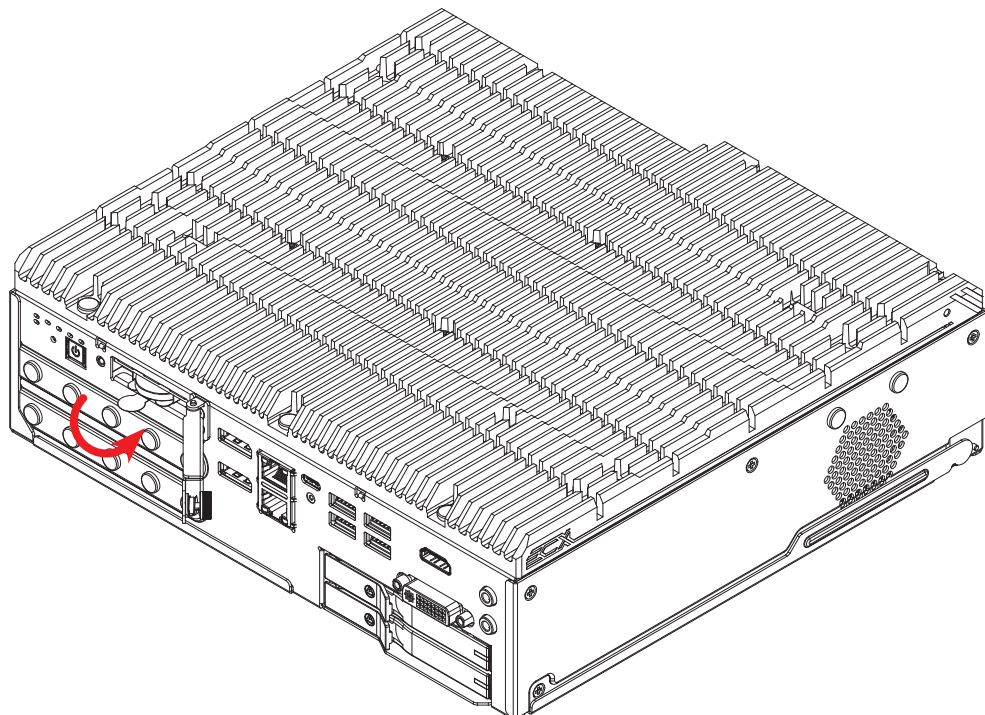

**Step 3** Insert removable RTC battery.

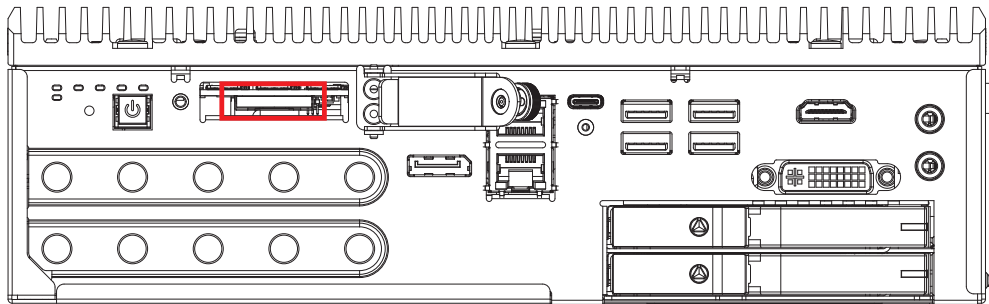

### 3.6 Installing PCI/PCI Card

System designs will support 126 mm maximum height, 219 mm maximum length (Without the I/O bracket & auxiliary power card) PCI/PCI Express add-in cards.

**Step 1** Remove eight flat head M3x5L screws.

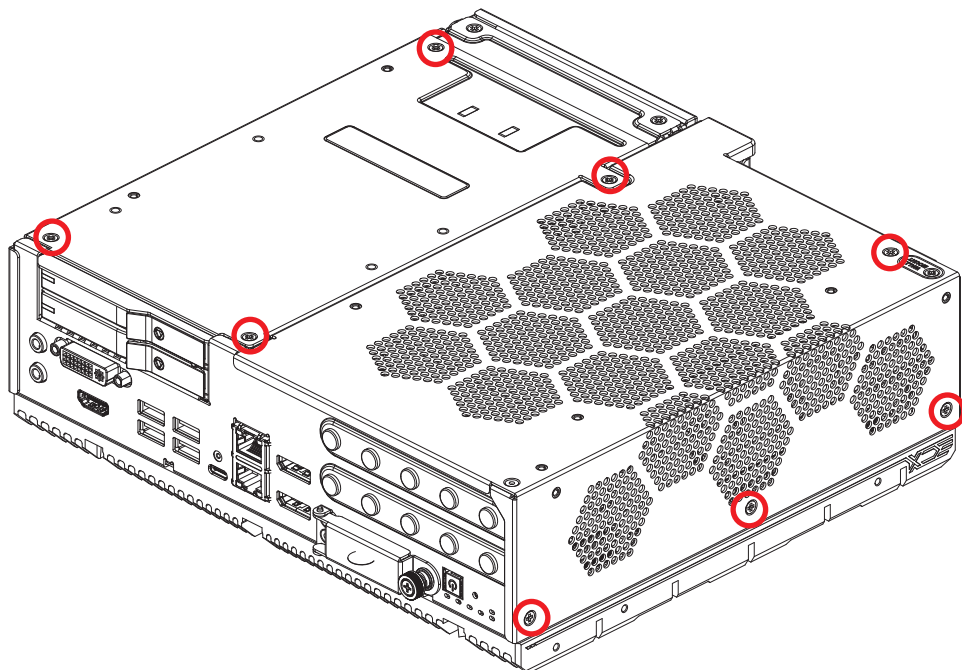

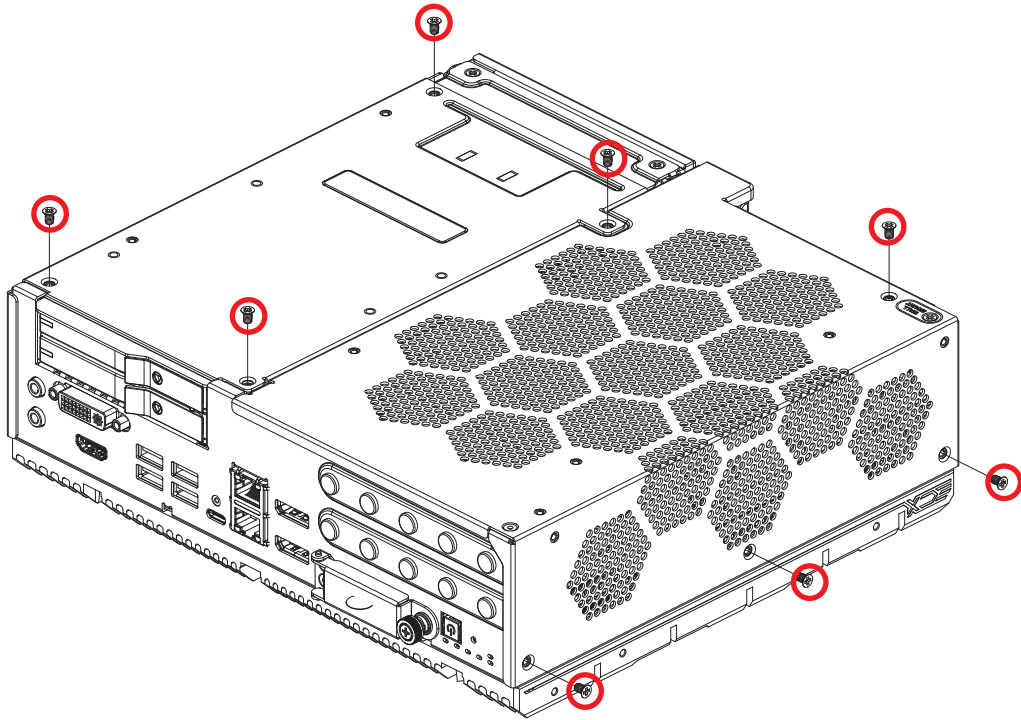

**Step 2** Open bottom cover & add-in card cover.

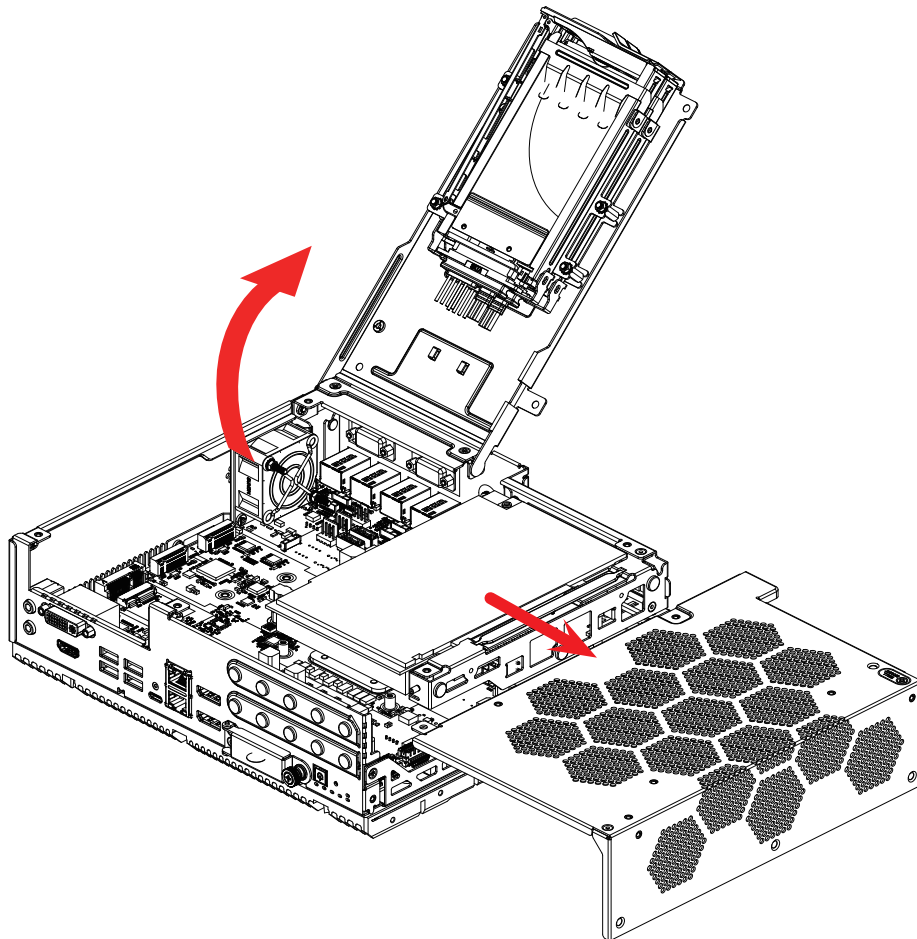

**Step 3** Separate Assembly\_Riser Card from the enclosure with the puller.

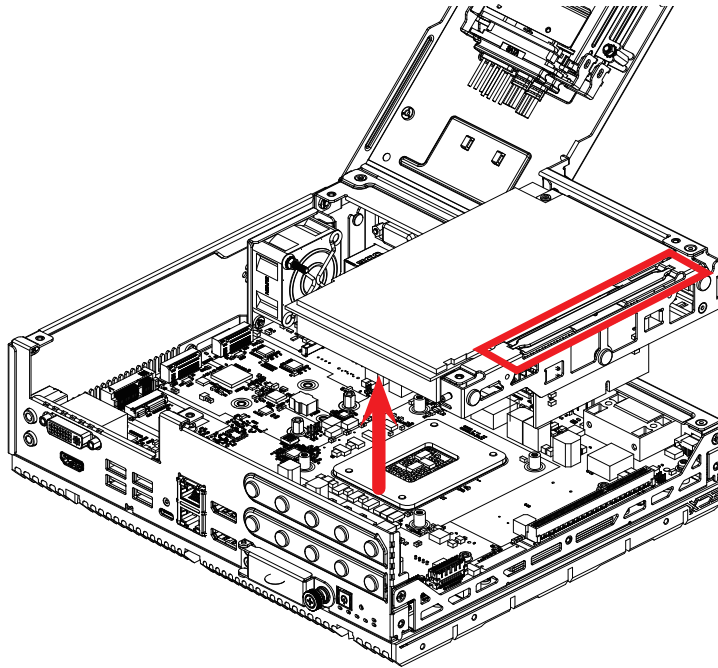

**Step 4** Turn riser card assembly upside-down on a steady surface.

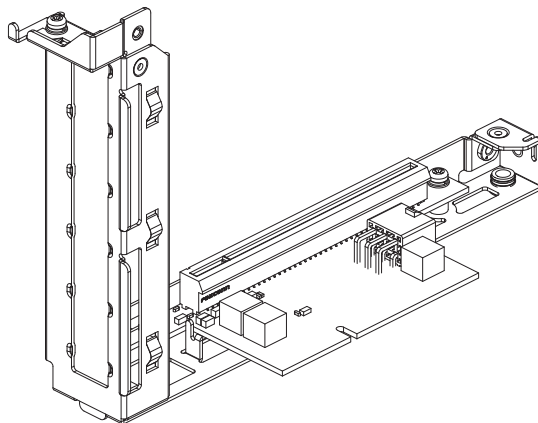

**Step 5** Remove the screw indicated, and separate I/O bracket from riser card assembly.

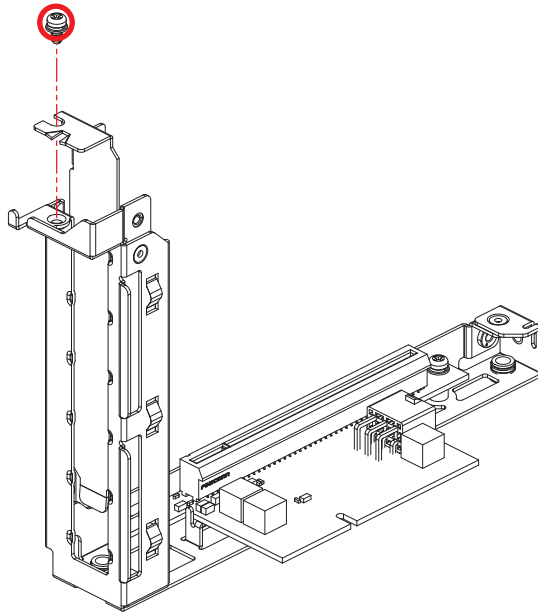

**Step 6** Instal PCI/PCIe add-in card, and fasten the screw indicated.

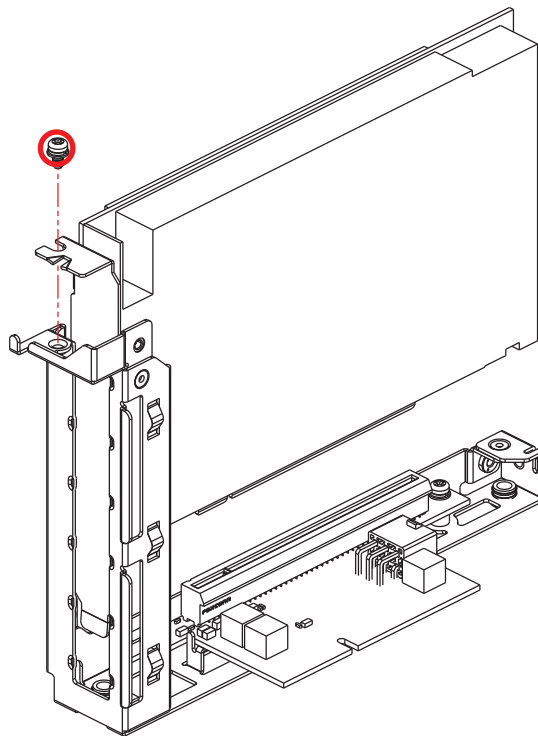

### 3.7 Installing SSD/HDD

**Step 1** Use the trigger and open SSD/HDD tray.



**Step 2** Open front door of SSD/HDD tray.



**Step 3** Install 2.5" SSD/HDD into the tray and close.



**Step 4** Lock the SSD/HDD tray with key.





## 3.8 Installing M.2

### 3.8.1 M.2 Key M 2280

**Step 1** Remove **four flat head M3x5L screws**, **four pan head SFW M3x6L screws** and **pan head SFW M2.5x6L screw**, and take out heat sink.

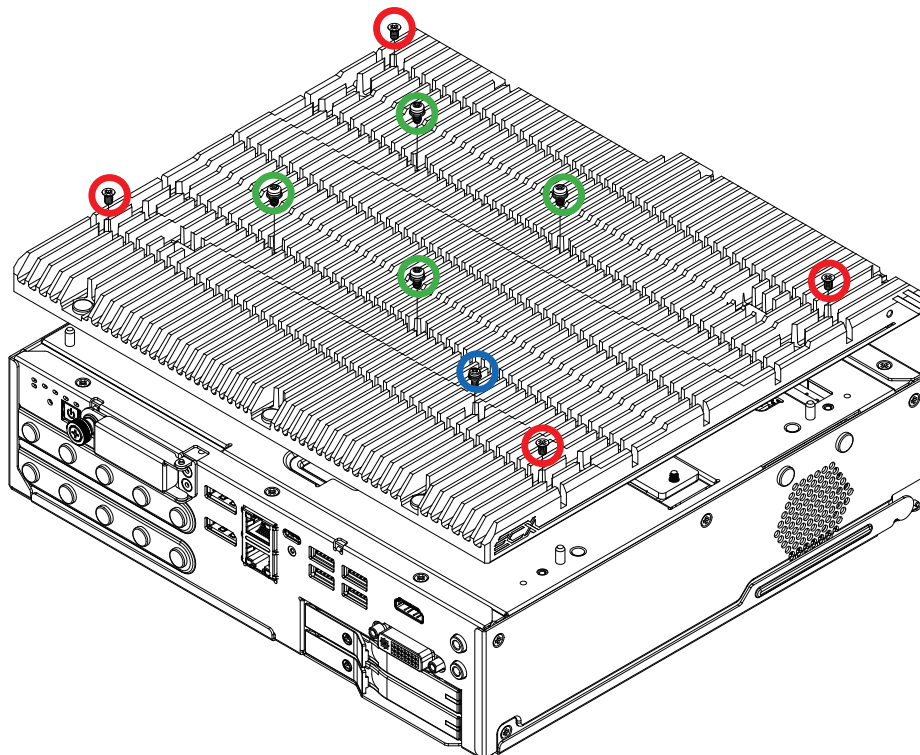
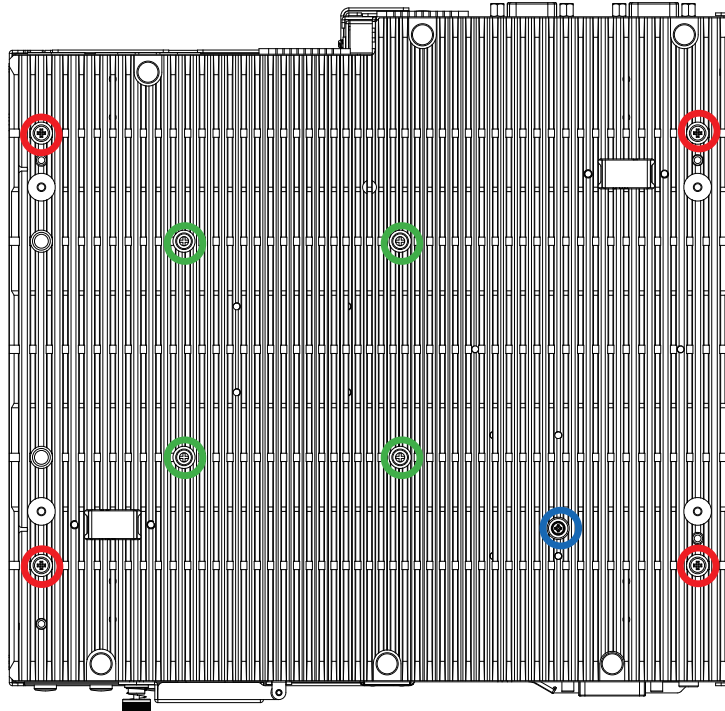

**Step 2** Take out heat sink, and install M.2 module card into slot and fasten I head M3x4L screw.

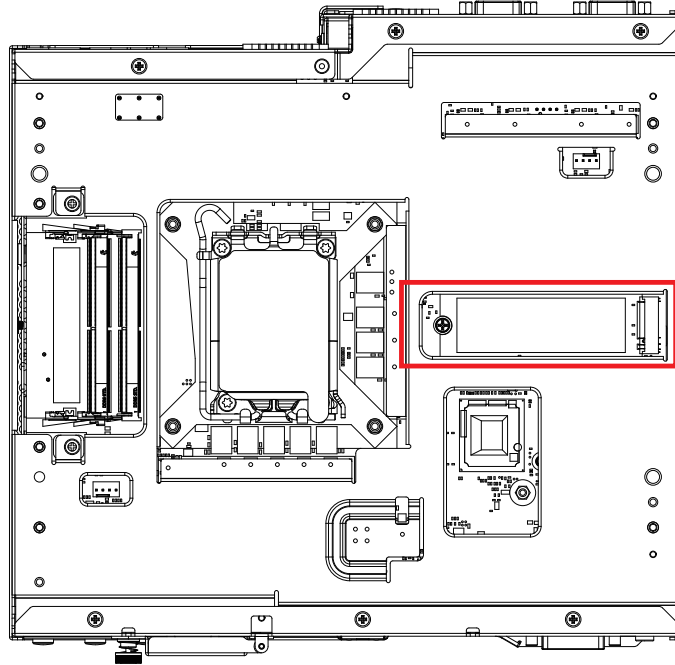

### 3.8.2 M.2 Key B 3042/3052/2280 & Key E 2230

**Step 1** Remove four flat head M3x5L screws.

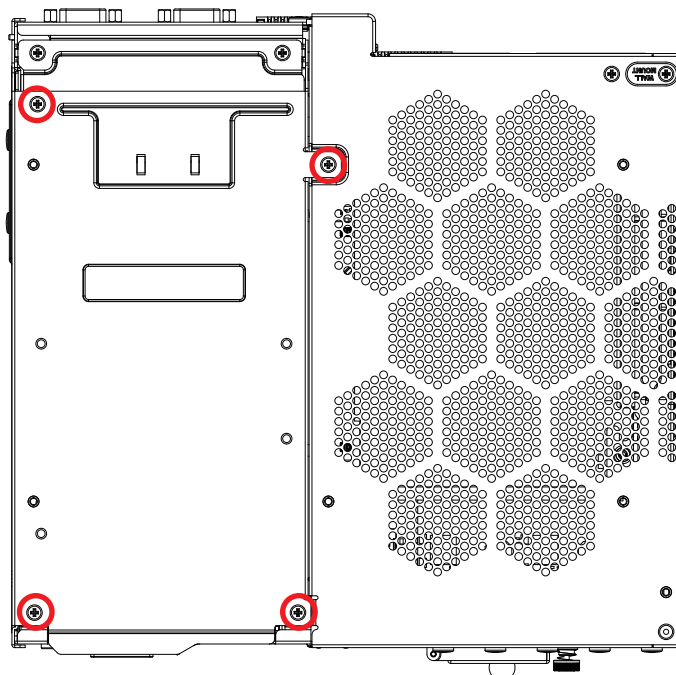

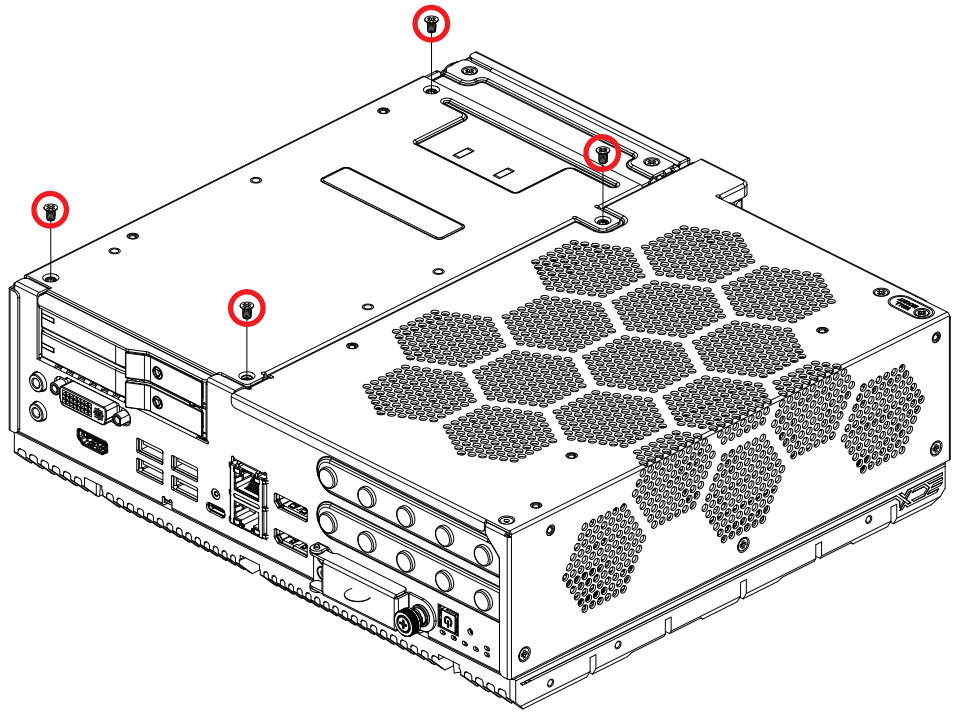

**Step 2** Open bottom cover.

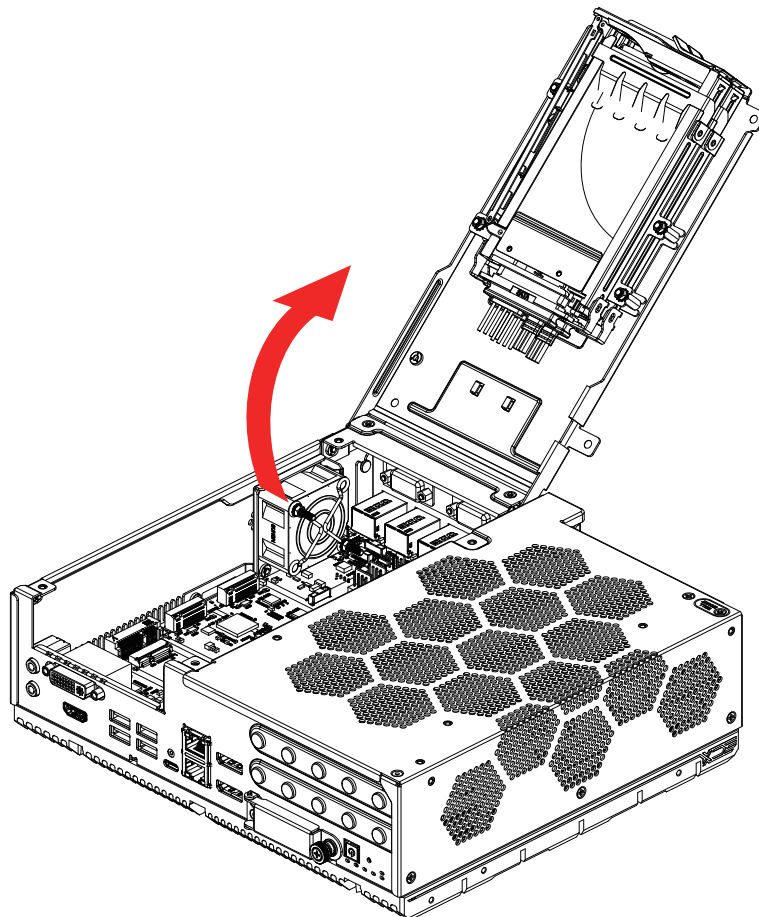

**Step 3** **M.2 Key B 3052/2280:** Remove hexagon M3 standoff on the position of Key B 2280, and install hexagon M3 standoff on the position of Key B 3052, and install M.2 Key B 3052 module card and fasten I head M3x4L screw.

**M.2 Key B 3042/2280:** Remove hexagon M3 standoff on the position of Key B 2280, and install hexagon M3 standoff on the position of Key B 3042, and install M.2 Key B 3042 module card and fasten I head M3x4L screw.

**M.2 Key E 2230 :** Install M.2 Key E 2230 module card into slot, and fasten I head M3x4L screw

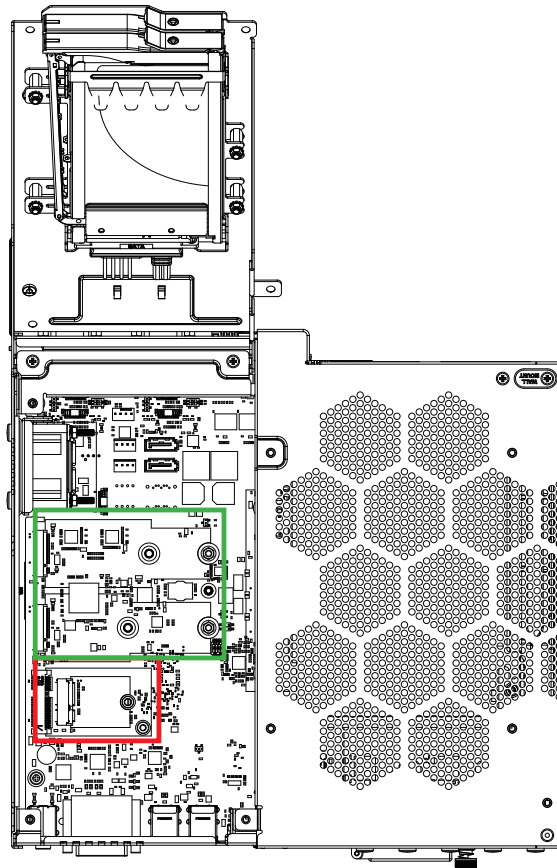

## 3.9 Installing Antenna Cable

**Step 1** Remove eight flat head M3x5L screws.

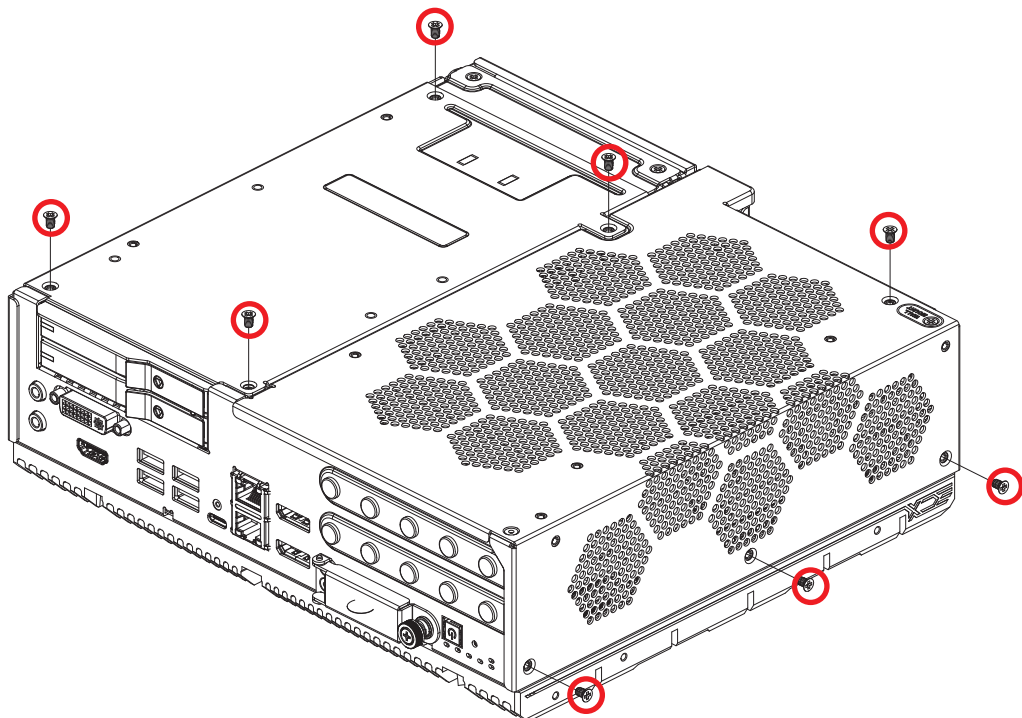
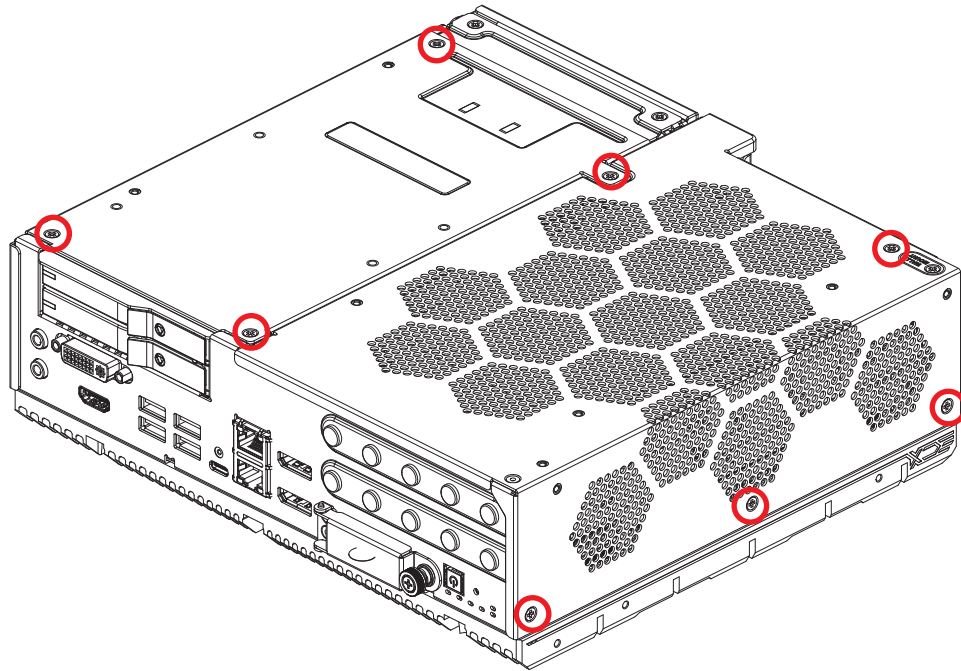

**Step 2** Open bottom cover & add-in card cover.

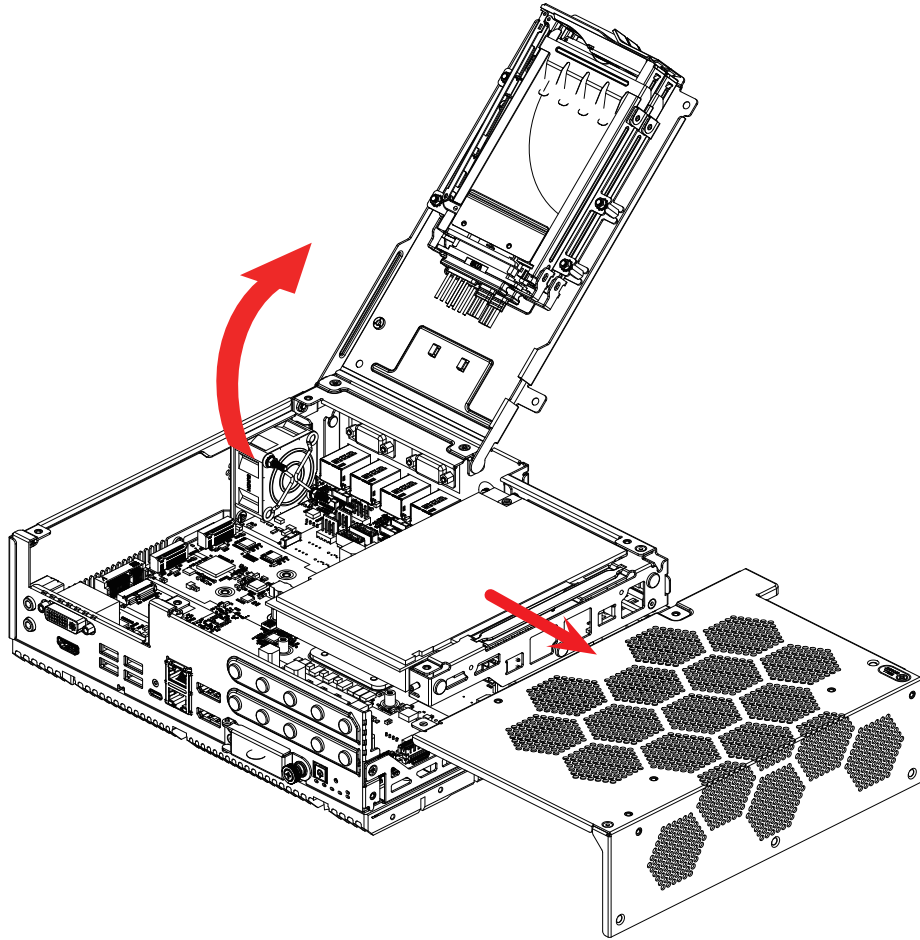

**Step 3** Separate Assembly\_Riser Card from the enclosure with the puller.

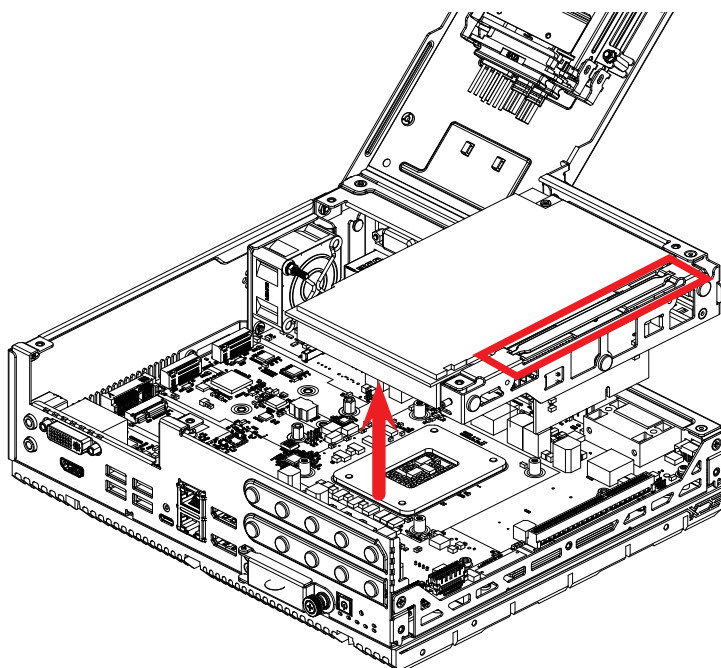

**Step 4** Remove hole plug.

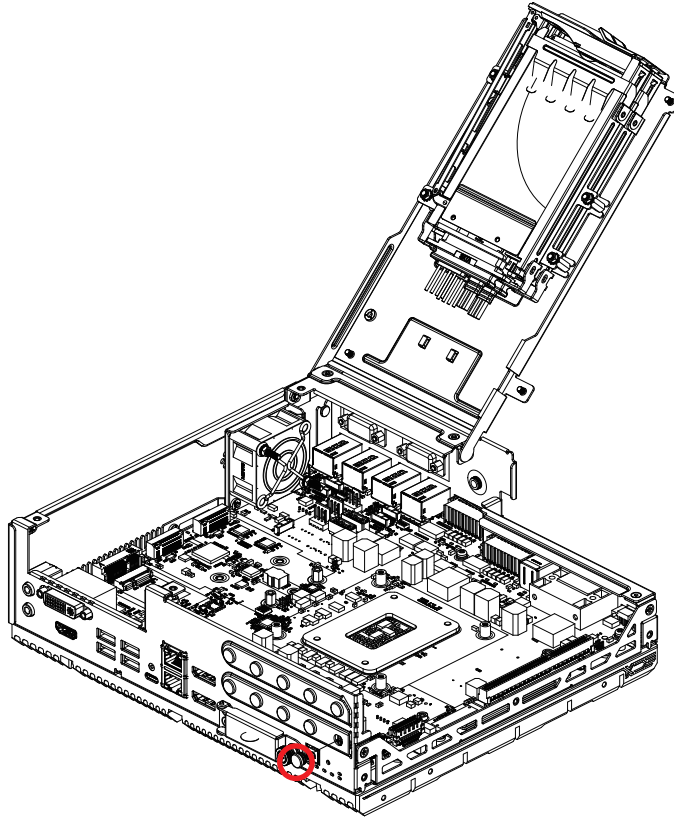

**Step 5** Install SMA cable, and fasten washer and nut.

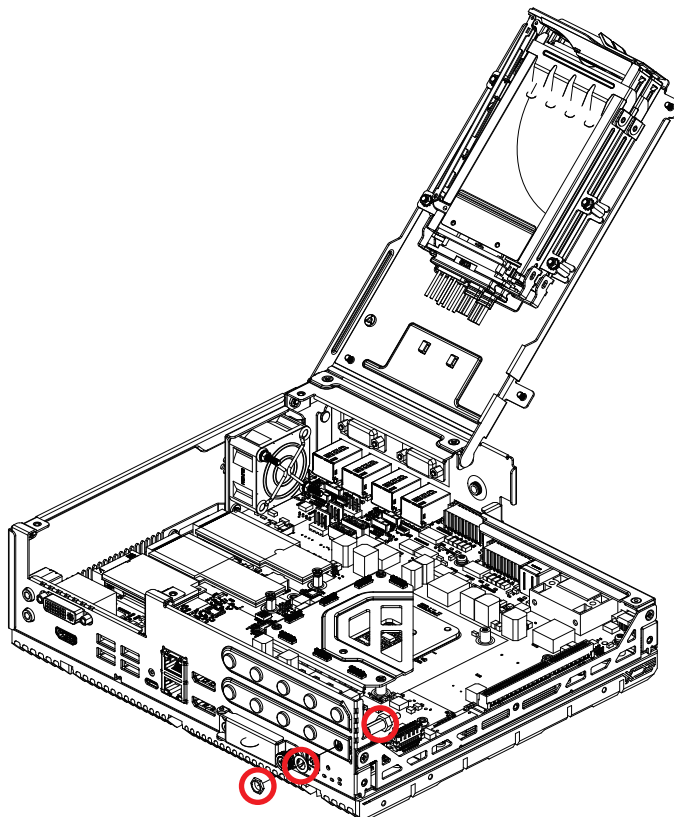

## 3.10 Mounting Your ECX-3000-PEG

### 3.10.1 Wall Mount (Type I)

Fasten four flat head M3x5L screws.

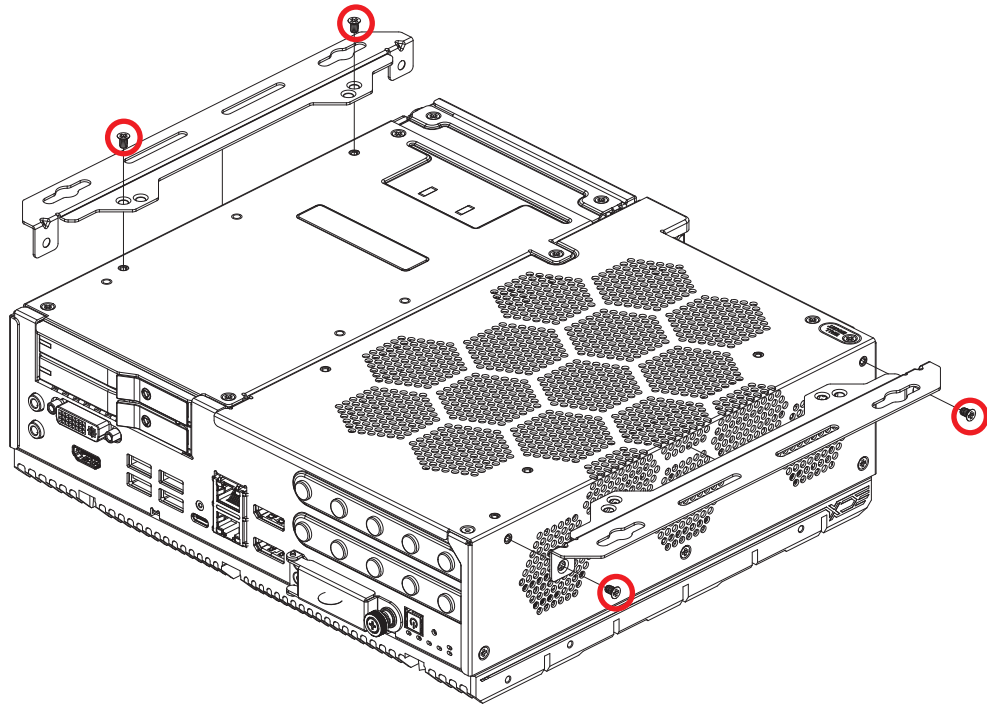



### 3.10.2 Wall Mount (Type II)

Fasten four flat head M3x5L screws.

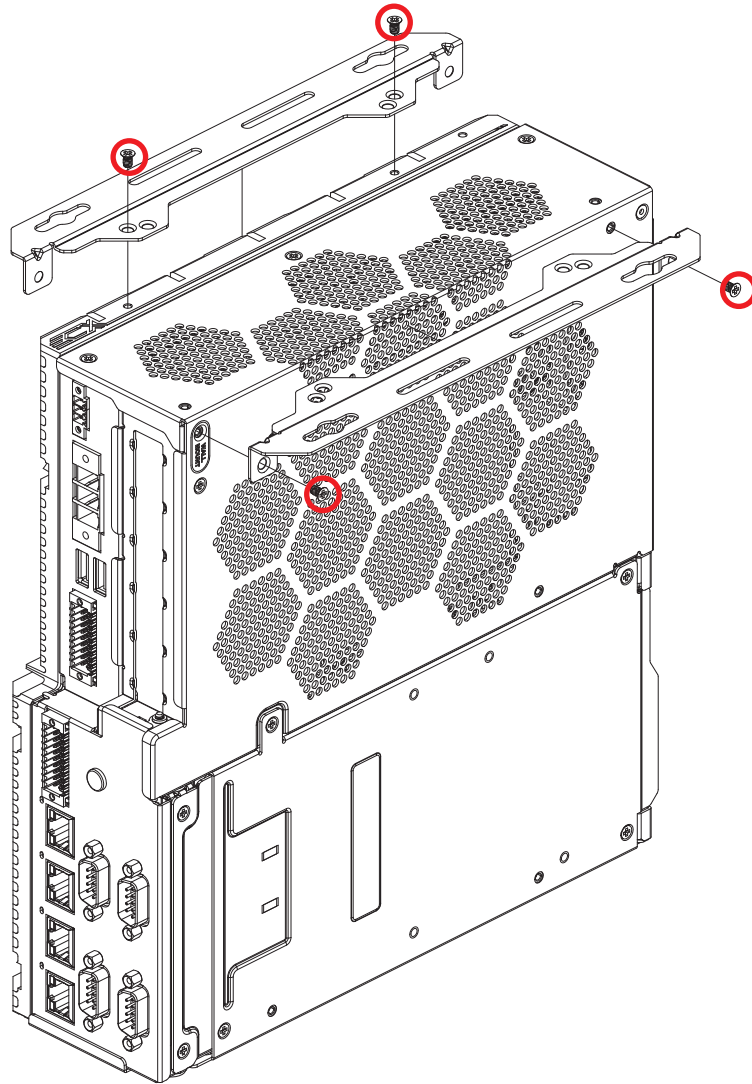

### 3.10.3 Wall Mount (Type III)

Fasten six flat head M3x5L screws.

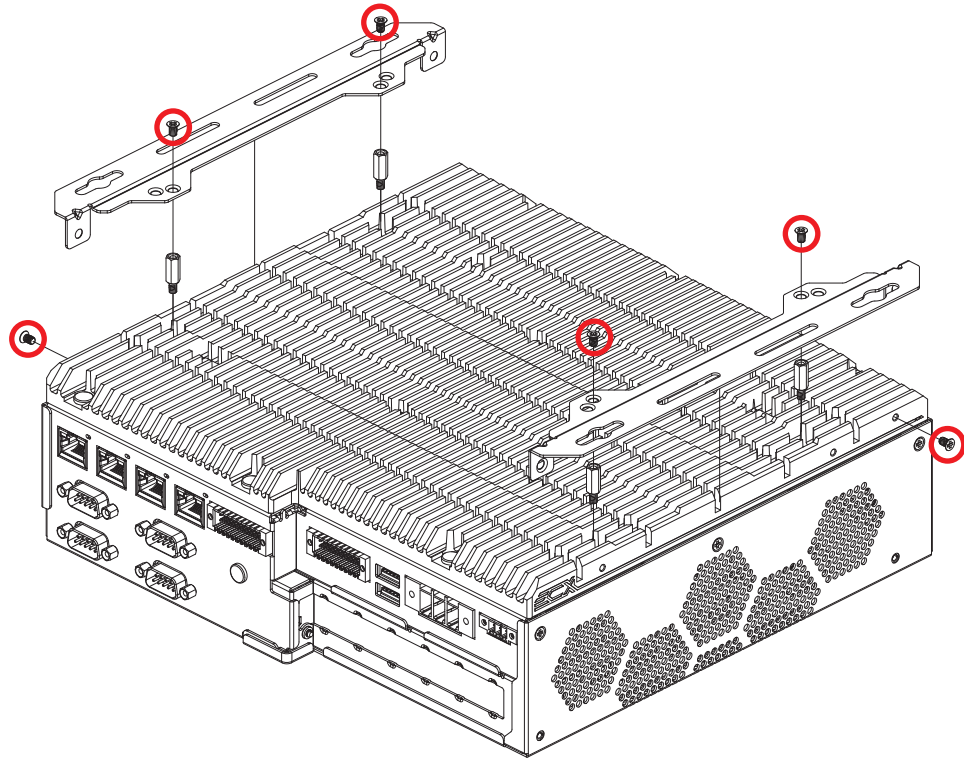

### 3.10.4 VESA Mount (Optional)

Fasten six flat head M3x5L screws.

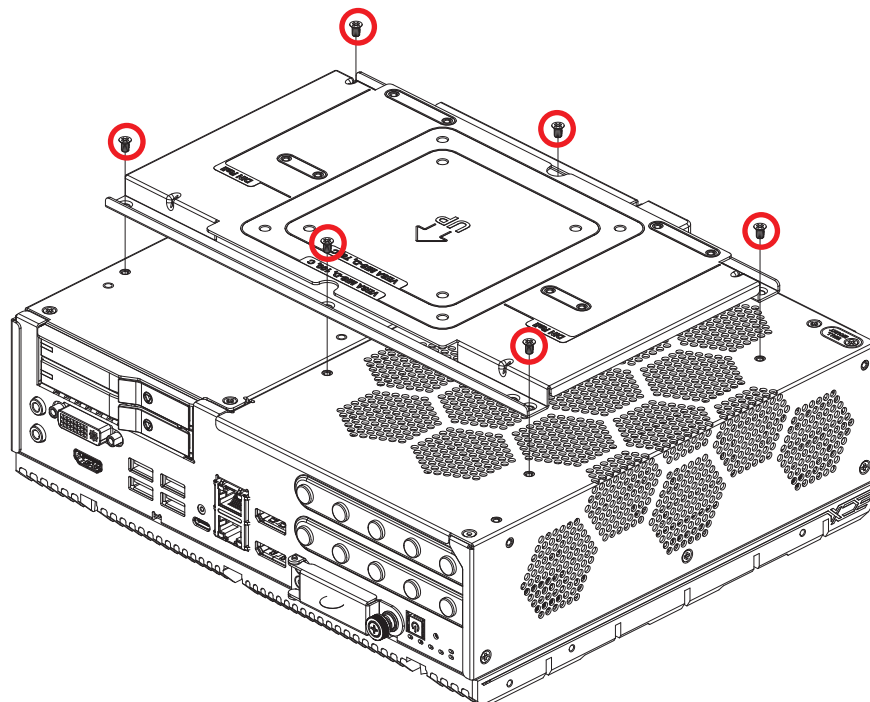

### 3.10.5 DIN Rail Mount (Optional)

Install DIN Rail with **eight flat head M3x5L screws**, and Install DIN Rail assembly with **six flat head M3x5L screws**.

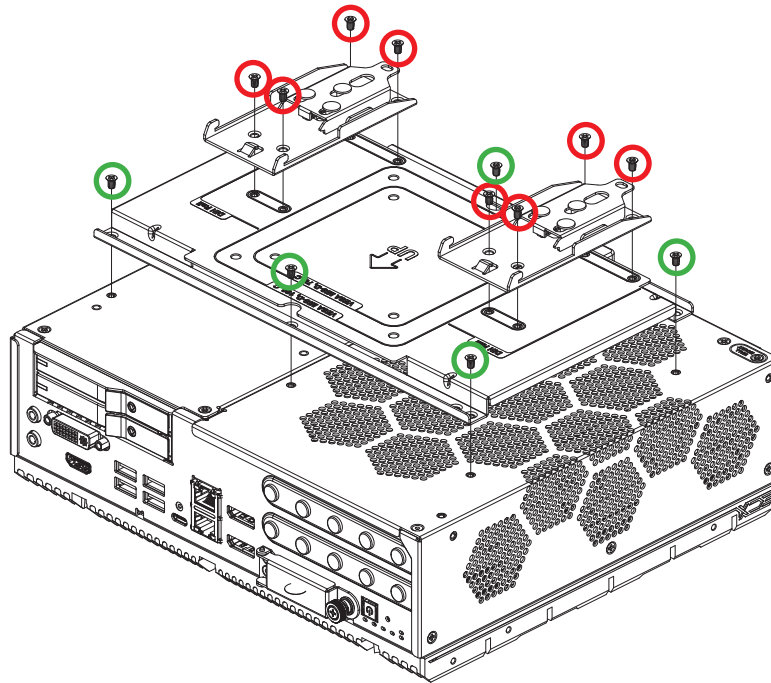

### 3.10.6 2U Rack Mount (Optional)

The 2U Rackmount is only for ECX-3200/3200MX/3100 PEG Series. For more information, please contact Vecow support team.

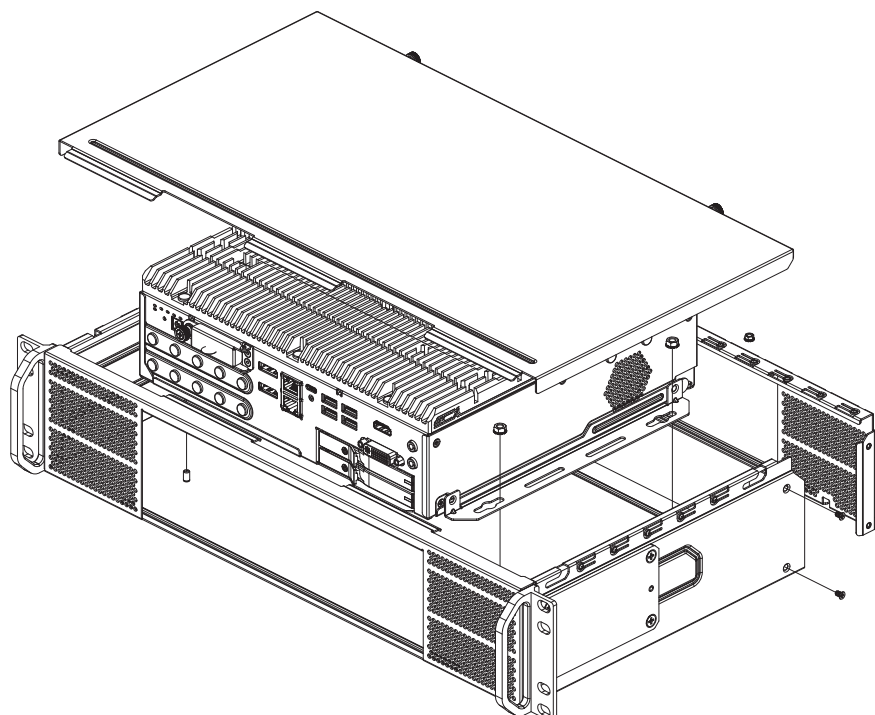

# 4

## BIOS SETUP

### 4.1 Entering BIOS Setup

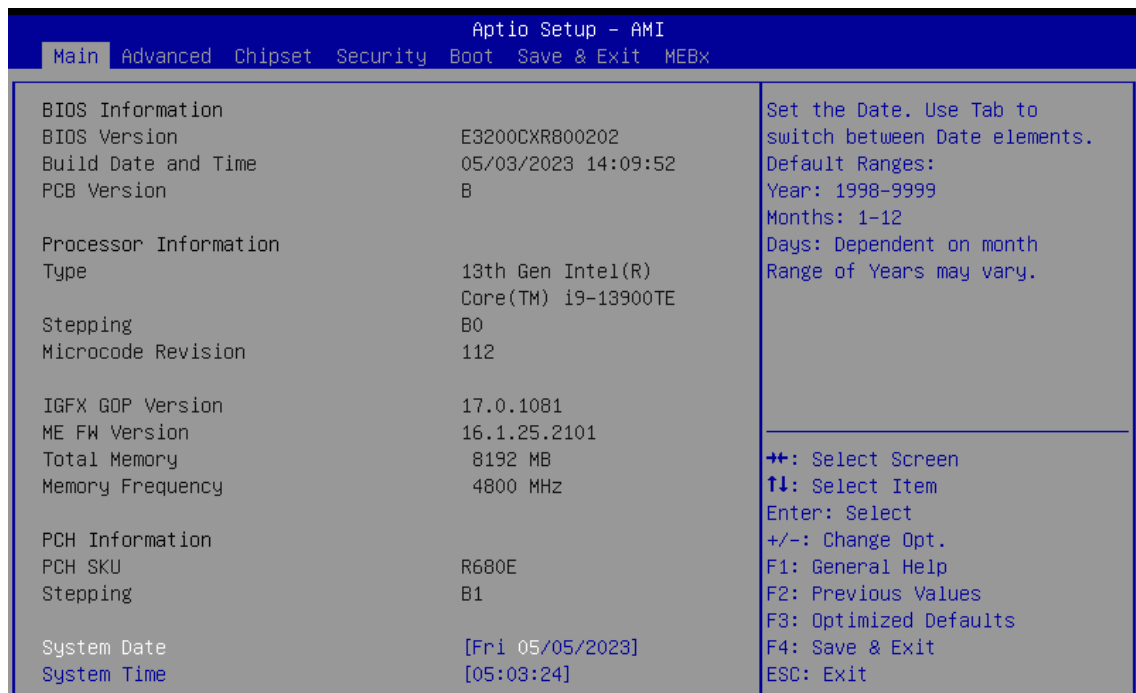

Figure 4-1 : Entering Setup Screen

BIOS provides an interface for users to check and change system configuration. The BIOS setup program is accessed by pressing the <Del> key when POST display output is shown.

## 4.2 Main Menu

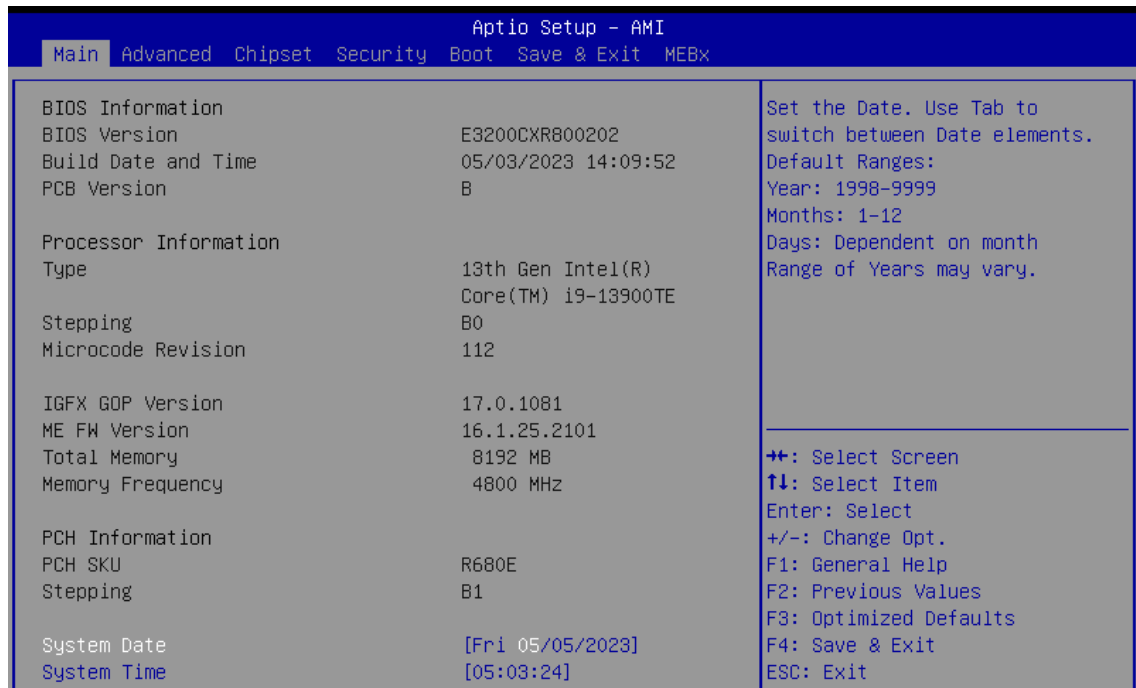

Figure 4-2 : BIOS Main Menu

The main menu displays BIOS version and system information. There are two options on Main menu.

### System Date

Set the Date. Use <Tab> to switch between Date elements.

Default Ranges:

Year: 1998-9999

Months: 1-12

Days: Dependent on month

Range of Years may vary.

### System Time

Set the Time. Use <Tab> to switch between Time elements.

## 4.3 Advanced Menu

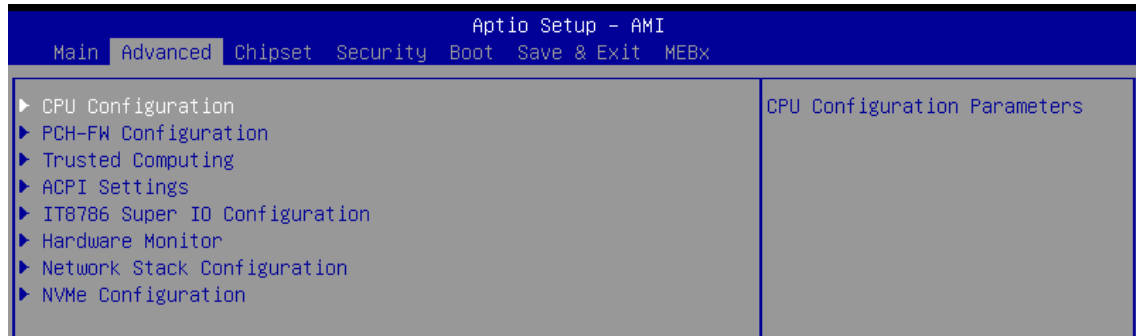

Figure 4-3 : BIOS Advanced Menu

Select advanced tab to enter advanced BIOS setup options, such as CPU configuration, ACPI settings, and Super IO configuration.

### 4.3.1 CPU Configuration

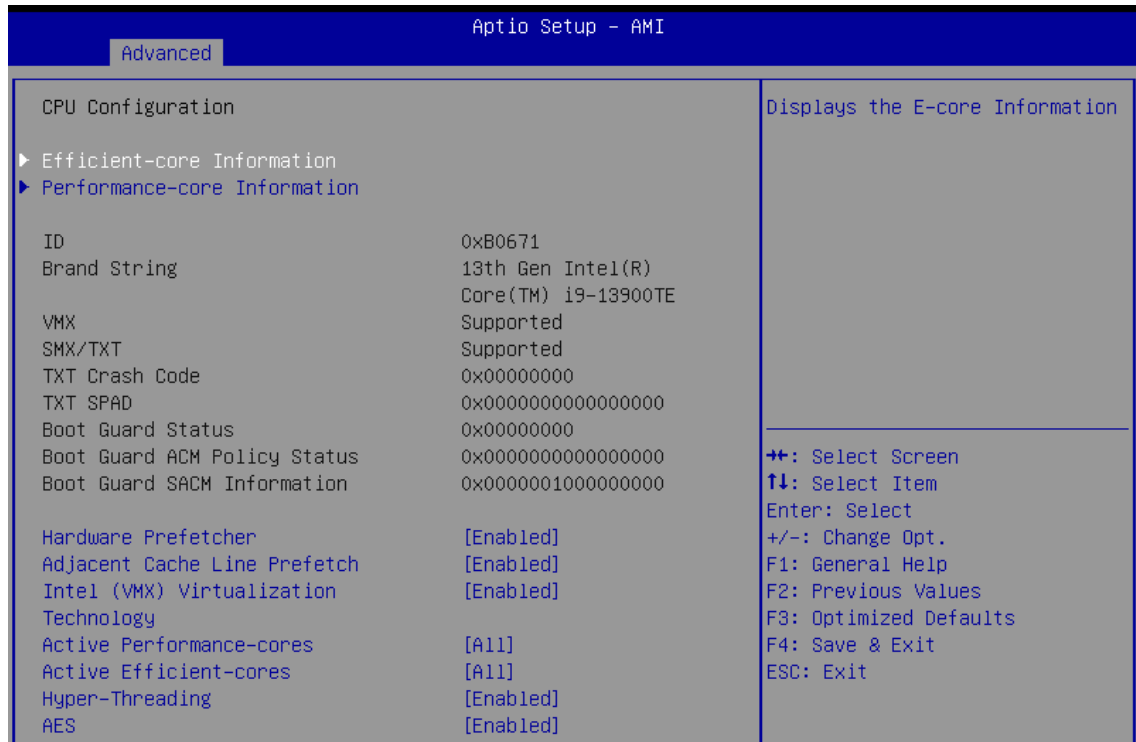

Figure 4-3-1 : CPU Configuration

#### Efficient-core Information

Displays the E-core Information.

#### Performance-core Information

Displays the P-core Information.

#### Hardware Prefetcher

To turn on/off the MLC streamer prefetcher.

#### Adjacent Cache Line Prefetch

To turn on/off prefetching of adjacent cache lines.

### Intel (VMX) Virtualization Technology

When enabled, a VMM can utilize the additional hardware capabilities provided by Vanderpool Technology.

### Active Performance-cores

Number of P-cores to enable in each processor package. Note: Number of Cores and E-cores are looked at together. When both are {0,0}, Pcode will enable all cores.

### Active Efficient-cores

Number of E-cores to enable in each processor package. Note: Number of Cores and E-cores are looked at together. When both are {0,0}, Pcode will enable all cores.

### Hyper-Threading

Enable or Disable Hyper-Threading Technology.

### AES

Enable/Disable AES (Advanced Encryption Standard).

## 4.3.2 PCH-HW Configuration

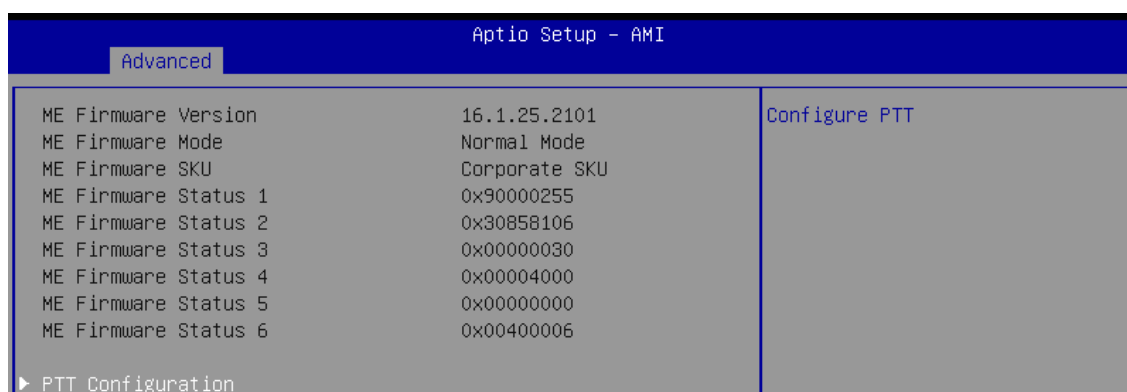

Figure 4-3-2 : PCH-HW Configuration

### PTT Configuration

Configure PTT.

### 4.3.2.1 PTT Configuration

| Aptio Setup - AMI      |        |   |
|------------------------|--------|---|
| Advanced               |        |   |
| PTT Capability / State | 1 / 0  | Selects TPM device: PTT or dTPM. PTT - Enables PTT in SkuMgr dTPM 1.2 - Disables PTT in SkuMgr Warning ! PTT/dTPM will be disabled and all data saved on it will be lost. |
| TPM Device Selection   | [dTPM] |   |

Figure 4-3-2-1 : PTT Configuration

#### PTT Capability / State

Platform Trust Technology Capability / Enablement State.

#### TPM Device Selection

Selects TPM device: PTT or discrete TPM.

PTT - Enables PTT in SkuMgr dTPM 1.2 - Disables PTT in SkuMgr Warning!  
PTT/dTPM will be disabled and all data saved on it will be lost.

### 4.3.3 Trusted Computing

| Aptio Setup - AMI       |           |   |
|-------------------------|-----------|---|
| Advanced                |           |   |
| TPM 2.0 Device Found    |           | Enables or Disables BIOS support for security device. O.S. will not show Security Device. TCG EFI protocol and INT1A interface will not be available. |
| Firmware Version:       | 7.85      |   |
| Vendor:                 | IFX       |   |
| Security Device Support | [Enable]  |   |
| Active PCR banks        | SHA256    |   |
| Available PCR banks     | SHA256    |   |
| SHA256 PCR Bank         | [Enabled] |   |

Figure 4-3-3 : Trusted Computing

Control the TPM device status and display related information if TPM chip is present.

### 4.3.4 ACPI Settings

| Aptio Setup - AMI  |                       |  |
|--------------------|-----------------------|--|
| Advanced           |                       |  |
| ACPI Settings      |                       | Enables or Disables System ability to Hibernate (OS/S4 Sleep State). This option may not be effective with some operating systems. |
| Enable Hibernation | [Enabled]             |  |
| ACPI Sleep State   | [S3 (Suspend to RAM)] |  |

Figure 4-3-4 : ACPI Settings

#### Enable Hibernation

Enables or Disables System ability to Hibernate (OS/S4 Sleep State). This option may not be effective with some operating systems.

#### ACPI Sleep State

Selects the highest ACPI sleep state the system will enter when the SUSPEND button is pressed.



### 4.3.5 IT8786 Super IO Configuration

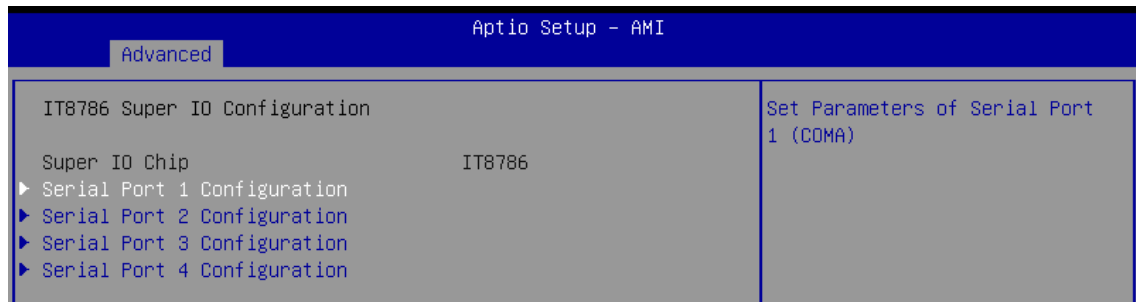

Figure 4-3-5 : IT8786 Super IO Configuration

#### 4.3.5.1 Serial Port X Configuration

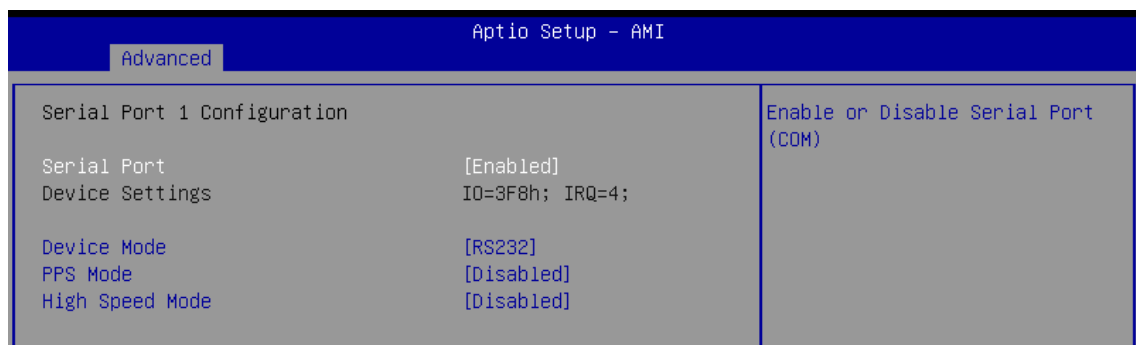

Figure 4-3-5-1 : Serial Port X Configuration

#### **Serial Port**

Enable or Disable Serial Port (COM).

#### **Device Mode**

Select Device Mode.

#### **PPS Mode**

Enable or Disable PPS.

#### **High Speed Mode**

Enable or disable High Speed Serial Port.

Note: A device driver is required on OS for high speed serial port function.

(High Speed Serial Port is Port 1 only)

## 4.3.6 Hardware Monitor

| Pc Health Status     |             | Smart Fan function setting |
|----------------------|-------------|----------------------------|
| CPU temperature      | : +31 %     |                            |
| SYS temperature      | : +61 %     |                            |
| Fan1 Speed (CPU)     | : 1839 RPM  |                            |
| Fan2 Speed (SYS)     | : 505 RPM   |                            |
| VCORE                | : +0.773 V  |                            |
| VRAM                 | : +1.090 V  |                            |
| 12V                  | : +11.968 V |                            |
| 5V                   | : +5.014 V  |                            |
| 3.3V                 | : +3.307 V  |                            |
| ▶ Smart Fan Function |             |                            |

Figure 4-3-6 : Hardware Monitor

The IT8786 SIO features an enhanced hardware monitor providing thermal, fan speed, and system voltages' status monitoring.

### 4.3.6.1 Smart Fan Function

| Fan 1 Setting (CPU)              |                  | Smart Fan Mode Select |
|----------------------------------|------------------|-----------------------|
| Smart Fan 1 Mode                 | [Automatic Mode] |                       |
| Fan off temperature limit        | 0                |                       |
| Fan start temperature limit      | 45               |                       |
| Fan full speed temperature limit | 90               |                       |
| Fan start PWM                    | 15               |                       |

Figure 4-3-6-1 : Smart Fan Function

#### Smart Fan X Mode

Smart Fan Mode Select.

#### Fan off temperature limit

Fan will off when temperature lower than this limit.

#### Fan start temperature limit

Fan will work when temperature higher than this limit.

#### Fan full speed temperature limit

Fan will full speed when temperature higher than this limit.

#### Fan start PWM

Fan will start with this PWM value.

#### Manual PWM Setting

Fan will work with this Manual PWM Value.

### 4.3.7 Network Stack Configuration

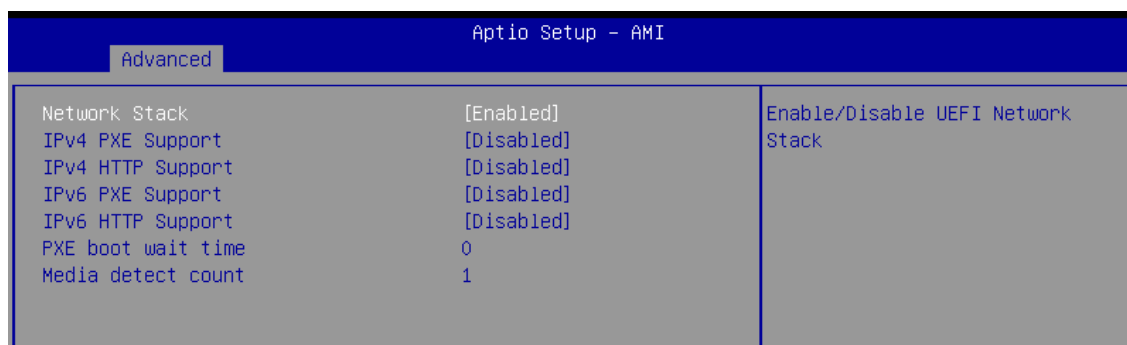

Figure 4-3-7 : Network Stack Configuration

#### Network Stack

Enable/Disable UEFI Network Stack.

#### IPv4 PXE Support

Enable/Disable IPv4 PXE boot support. If disabled, IPv4 PXE boot support will not be available.

#### IPv4 HTTP Support

Enable/Disable IPv4 HTTP boot support. If disabled, IPv4 HTTP boot support will not be available.

#### IPv6 PXE Support

Enable/Disable IPv6 PXE boot support. If disabled, IPv6 PXE boot support will not be available.

#### IPv6 HTTP Support

Enable/Disable IPv6 HTTP boot support. If disabled, IPv6 HTTP boot support will not be available.

#### PXE boot wait time

Wait time in seconds to press ESC key to abort the PXE boot. Use either +/- or numeric keys to set the value.

#### Media detect count

Number of times the presence of media will be checked. Use either +/- or numeric keys to set the value.

### 4.3.8 NVMe Configuration

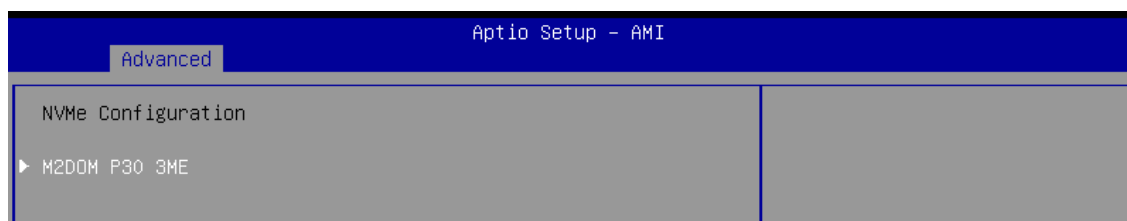

Figure 4-3-8 : NVMe Configuration

Display NVMe controller and Drive information.

## 4.4 Chipset Menu

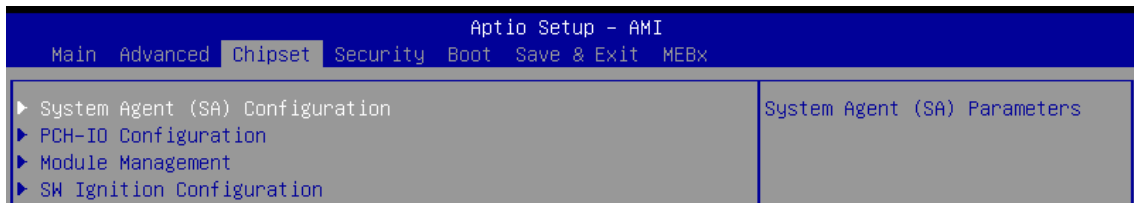

Figure 4-4 : BIOS Chipset Menu

Select Chipset tab to enter chipset BIOS setup options, such as System Agent (SA) Configuration, PCH-IO Configuration, and SW Ignition Configuration.

### 4.4.1 System Agent (SA) Configuration

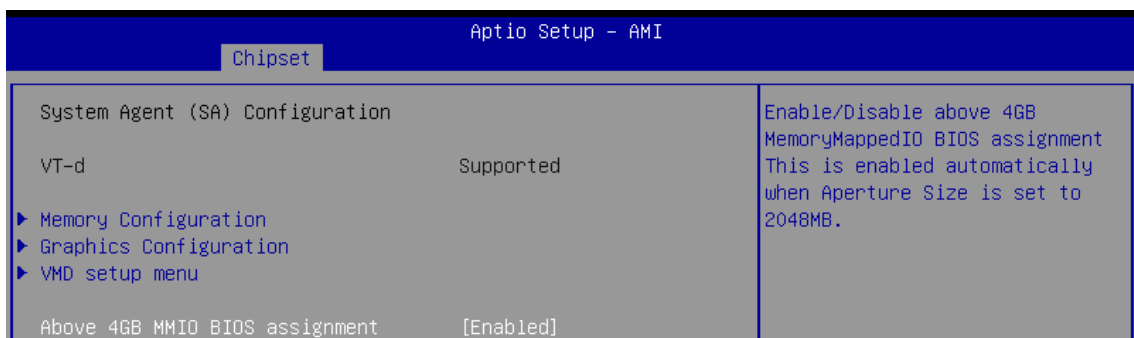

Figure 4-4-1 : System Agent (SA) Configuration

#### VT-d

VT-d capability.

#### Above 4GB MMIO BIOS assignment

Enable/disable above 4GB MemoryMappedIO BIOS assignment. This is enabled automatically when Aperture Size is set to 2048MB.

### 4.4.1.1 Memory Configuration

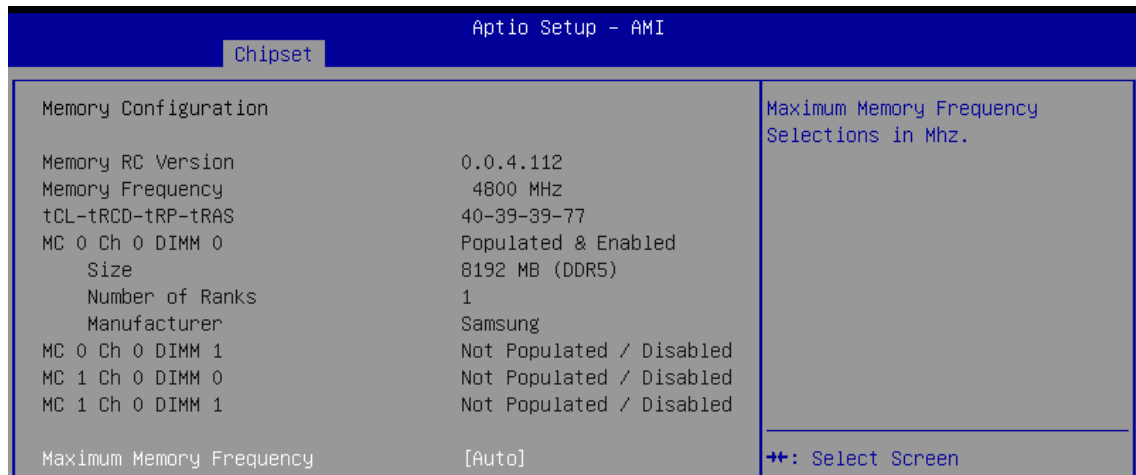

| Memory Configuration     |                          | Maximum Memory Frequency Selections in Mhz. |
|--------------------------|--------------------------|---|
| Memory RC Version        | 0.0.4.112                |   |
| Memory Frequency         | 4800 MHz                 |   |
| tCL-tRCD-tRP-tRAS        | 40-39-39-77              |   |
| MC 0 Ch 0 DIMM 0         | Populated & Enabled      |   |
| Size                     | 8192 MB (DDR5)           |   |
| Number of Ranks          | 1                        |   |
| Manufacturer             | Samsung                  |   |
| MC 0 Ch 0 DIMM 1         | Not Populated / Disabled |   |
| MC 1 Ch 0 DIMM 0         | Not Populated / Disabled |   |
| MC 1 Ch 0 DIMM 1         | Not Populated / Disabled |   |
| Maximum Memory Frequency | [Auto]                   | ↔: Select Screen                            |

Figure 4-4-1-1 : Memory Configuration

Displays memory information.

#### Maximum Memory Frequency

Maximum Memory Frequency Selections in Mhz.

### 4.4.1.2 Graphics Configuration

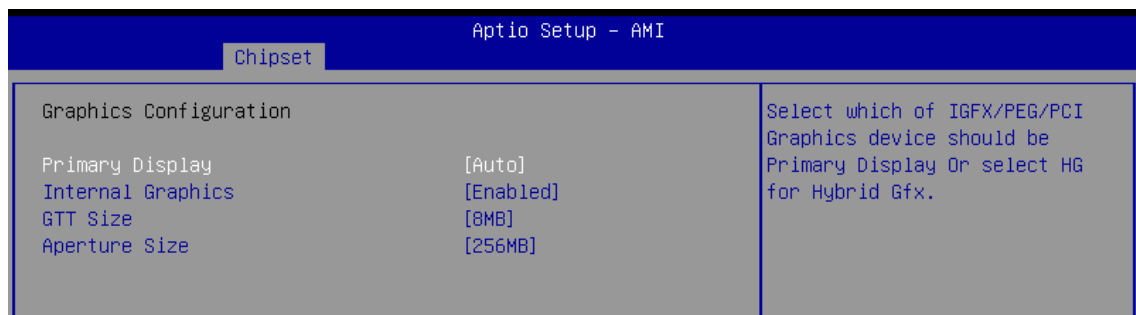

| Graphics Configuration |           | Select which of IGFX/PEG/PCI Graphics device should be Primary Display Or select HG for Hybrid Gfx. |
|------------------------|-----------|---|
| Primary Display        | [Auto]    |   |
| Internal Graphics      | [Enabled] |   |
| GTT Size               | [8MB]     |   |
| Aperture Size          | [256MB]   |   |

Figure 4-4-1-2 : Graphics Configuration

#### Primary Display

Select which of IGFX/PEG/PCI Graphics device should be Primary Display.

#### Internal Graphics

Keep IGFX enabled based on the setup options.

#### GTT Size

Select the GTT Size.

#### Aperture Size

Select the Aperture Size.

Note : Above 4GB MMIO BIOS assignment is automatically enabled when selecting 2048MB aperture. To use this feature, please disable CSM Support.

### 4.4.1.3 VMD setup menu



Figure 4-4-1-3 : VMD setup menu

#### Enable VMD controller

Enable/Disable to VMD controller.

### 4.4.2 PCH-IO Configuration

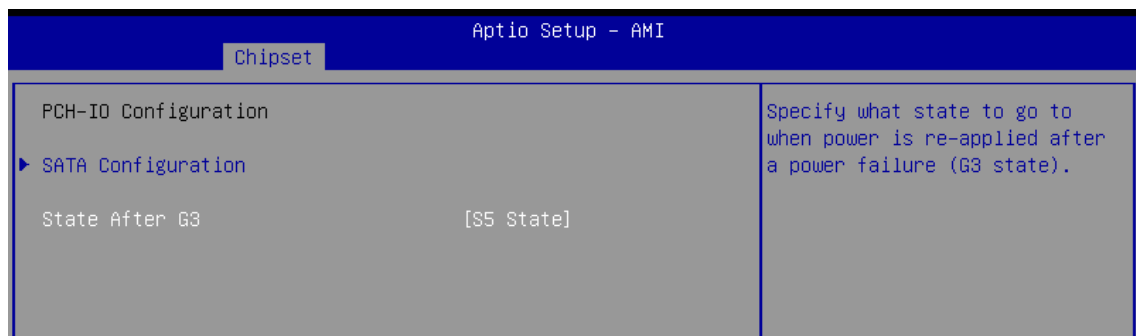

Figure 4-4-2 : PCH-IO Configuration

#### SATA Configuration

SATA Device Options Settings.

#### State After G3

Specify what state to go to when power is re-applied after a power failure (G3 state).

S0 State : Always turn-on the system when power source plugged-in.

S5 State : Always turn-off the system when power source plugged-in.

### 4.4.2.1 SATA Configuration

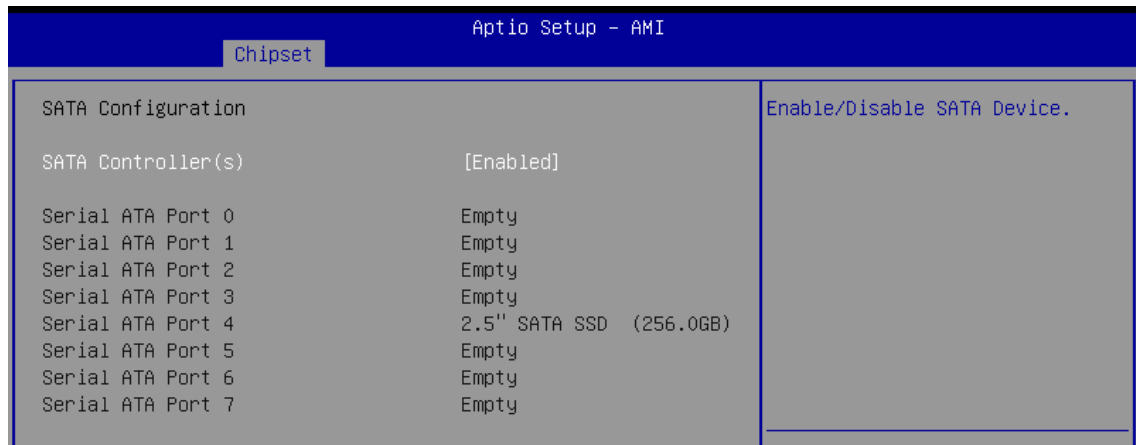

Figure 4-4-2-1 : SATA Configuration

### SATA Controller(s)

Enable / Disable SATA Device.

### 4.4.3 Module Management

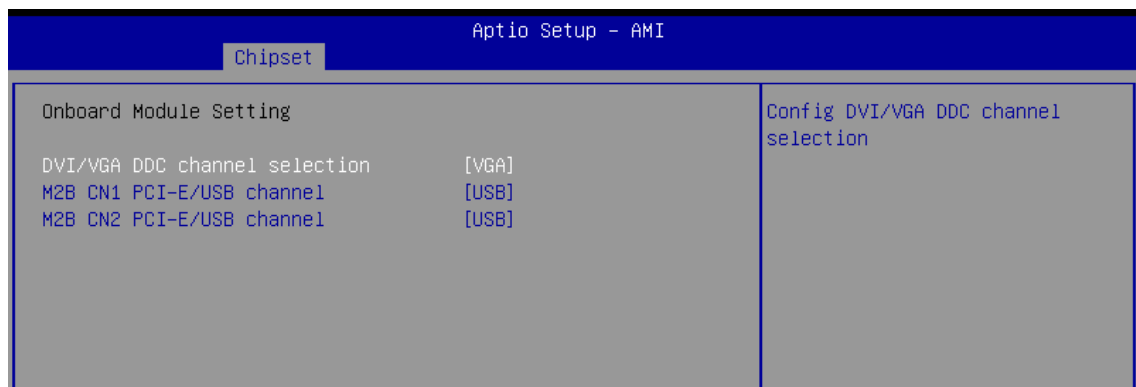

Figure 4-4-3 : Module Management

### DVI/VGA DDC channel selection

Configure DVI/VGA DCC channel selection.

### M2B CN1 PCI-E/USB channel

Select M2B CN1 PCI-E/USB channel selection.

### M2B CN2 PCI-E/USB channel

Select M2B CN2 PCI-E/USB channel selection.

## 4.4.4 SW Ignition Configuration

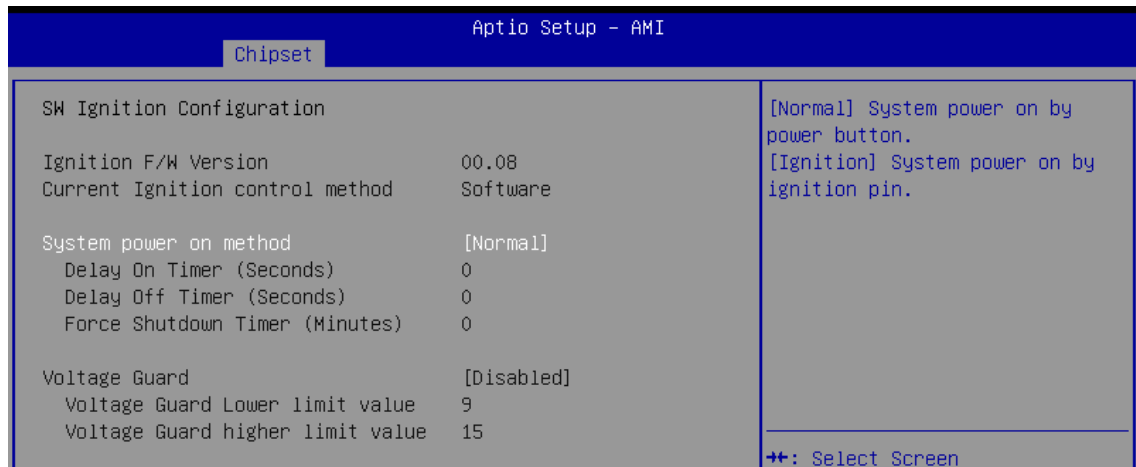

Figure 4-4-4 : SW Ignition Configuration

### System power on method

[Normal] System power on by power button.

[Ignition] System power on by ignition pin.

### Delay On Timer (Seconds)

The delay time after user trigger ignition on signal (Seconds).

### Delay Off Timer (Seconds)

The delay time after user trigger ignition off signal (Seconds)..

### Force Shutdown Timer (Minutes)

Used to force cut off system power when OS unable gracefully shutdown system successfully.

### Voltage Guard

Voltage Guard enable or disable, only effect on ignition mode.

### Voltage Guard lower limit value

Voltage Guard lower limit value setting

Range : 9V~40V

### Voltage Guard Higher limit value

Voltage Guard Higher limit value setting

Range : 15V~55V



## 4.5 Security Menu

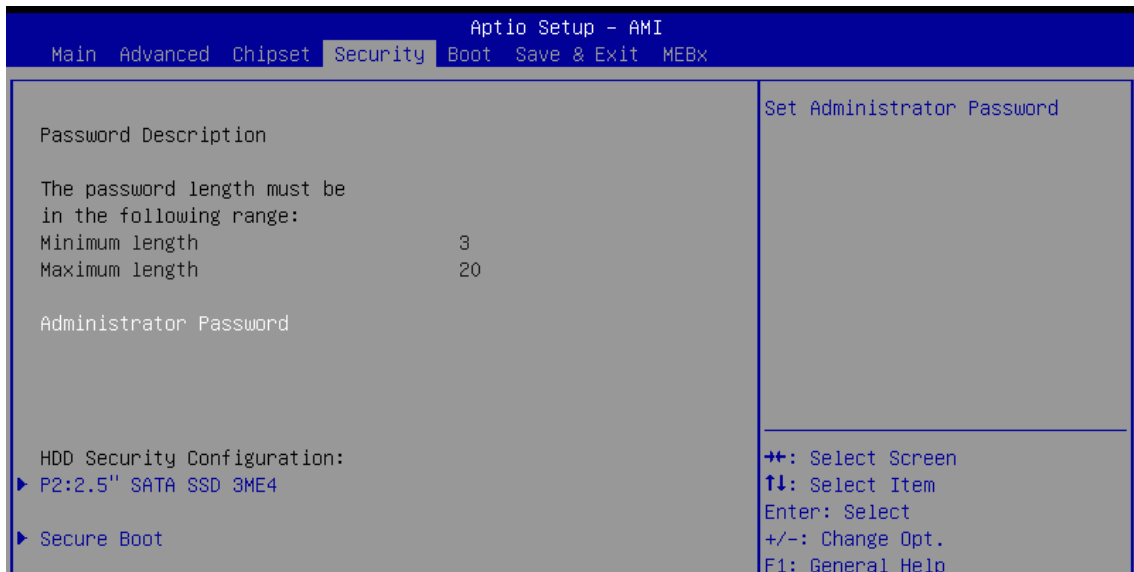

Figure 4-5 : BIOS Security Menu

### Administrator Password

Set administrator password.

## 4.5.1 HDD Security Configuration

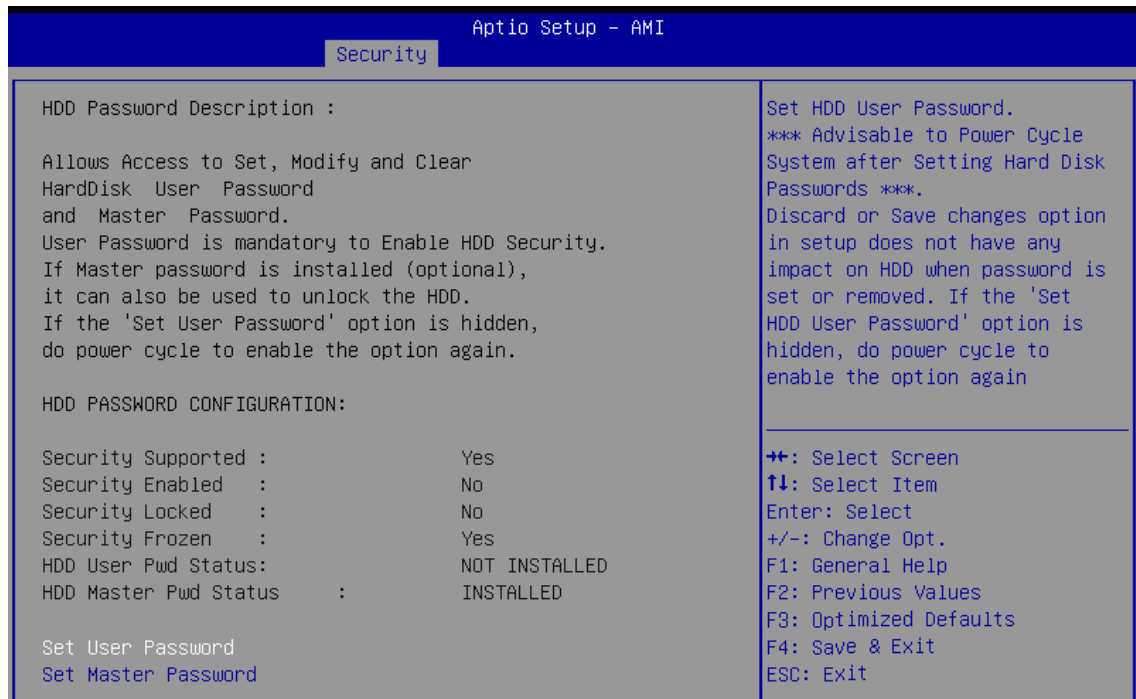

Figure 4-5-1 : HDD Security Configuration

### Set User Password

Set HDD User Password.

\*\*\* Advisable to Power Cycle System after Setting Hard Disk Passwords \*\*\*.

Discard or Save changes option in setup does not have any impact on HDD when password is set or removed. If the 'Set HDD User Password' option is hidden, do power cycle to enable the option again.

### Set Master Password

Set Master Password.

## 4.5.2 Security Boot

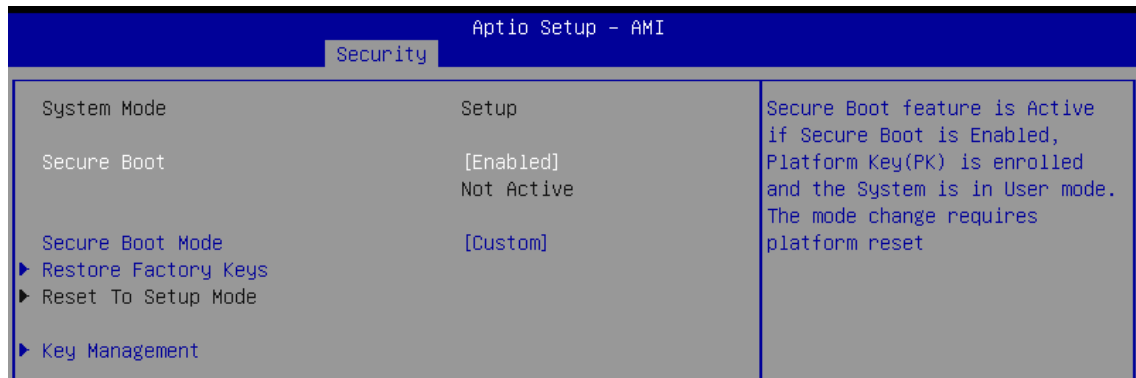

Figure 4-5-2 : Security Boot

### Secure Boot

Secure Boot feature is Active if Secure Boot is Enabled, Platform Key(PK) is enrolled and the System is in User mode. The mode change requires platform reset.

### Secure Boot Mode

Secure Boot mode options: Standard or Custom.

In Custom mode, Secure Boot Policy variables can be configured by a physically present user without full authentication.

### Restore Factory Keys

Force System to User Mode. Install factory default Secure Boot key databases.

### Reset To Setup Mode

Delete all Secure Boot key databases from NVRAM.

### Key Management

Enables expert users to modify Secure Boot Policy variables without variable authentication.

## 4.6 Boot Menu

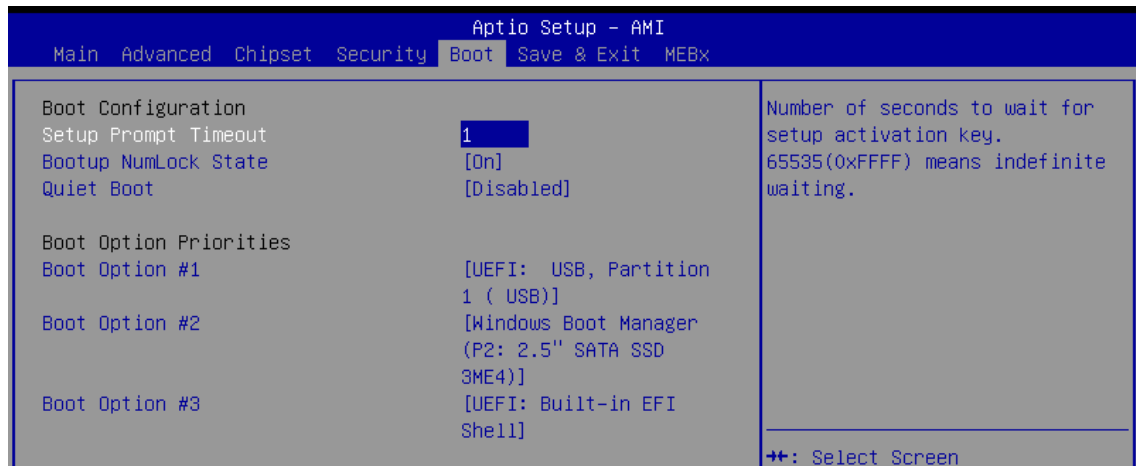

Figure 4-6 : BIOS Boot Menu

### Setup Prompt Timeout

Number of seconds to wait for setup activation key. 65535(0xFFFF) means indefinite waiting.

### Bootup NumLock State

Select the keyboard NumLock state.

### Quiet Boot

Enables or disables Quiet Boot option.

### Boot Option Priorities

Sets the system boot order.

## 4.7 Save & Exit

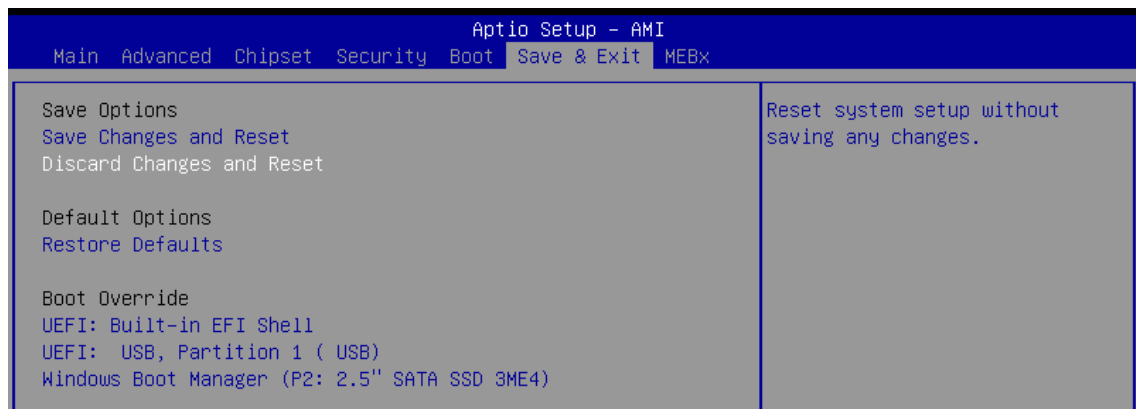

Figure 4-7 : BIOS Save and Exit Menu

### Save Changes and Reset

Reset the system after saving the changes.

### Discard Changes and Reset

Reset system setup without saving any changes.

### Restore Defaults

Restore/Load Default values for all the setup options.

# A

## APPENDIX A : Isolated DIO/GPIO Guide

### A.1 Function Description

The ECX-3000PEG series offers a 16-bit Non-Isolated DIO /two 16-bit Isolated DIO 20-pin terminal block connector, a watchdog timer, and a 4-port POE.

Isolated DIO pins are fix by Hardware design that cannot change in/out direction in runtime process.

DIO definition is shown below :

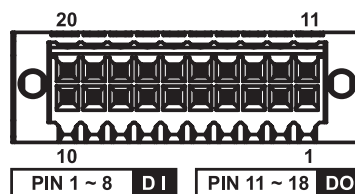

| Pin No. | DIO Definition | GPIO Definition | Pin No. | DIO Definition | GPIO Definition |
|---------|----------------|-----------------|---------|----------------|-----------------|
| 1       | DI 0           | DIO 0           | 11      | DO 0           | DIO 8           |
| 2       | DI 1           | DIO 1           | 12      | DO 1           | DIO 9           |
| 3       | DI 2           | DIO 2           | 13      | DO 2           | DIO 10          |
| 4       | DI 3           | DIO 3           | 14      | DO 3           | DIO 11          |
| 5       | DI 4           | DIO 4           | 15      | DO 4           | DIO 12          |
| 6       | DI 5           | DIO 5           | 16      | DO 5           | DIO 13          |
| 7       | DI 6           | DIO 6           | 17      | DO 6           | DIO 14          |
| 8       | DI 7           | DIO 7           | 18      | DO 7           | DIO 15          |
| 9       | DI COM         | NC              | 19      | DIO_GND        | DIO_GND         |
| 10      | DIO_GND        | DIO_GND         | 20      | External VDC   | NC              |

POE definition is shown below :

| Port No. | Definition | Port No. | Definition |
|----------|------------|----------|------------|
| 1        | POE 0      | 3        | POE 2      |
| 2        | POE 1      | 4        | POE 3      |

Do NOT use these functions in below :

1. PE-2000 : DIO1 (ID = 0), POE
2. PE-3000 : POE
3. UE-1000 : USB (ID = 0)

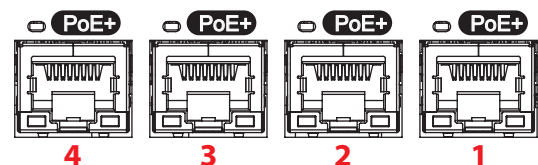

## A.2 Isolated DIO Signal Circuit

DI reference circuit :

Sink Mode  
(NPN)

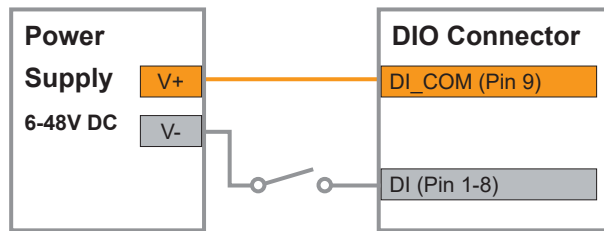

Source Mode  
(PNP)

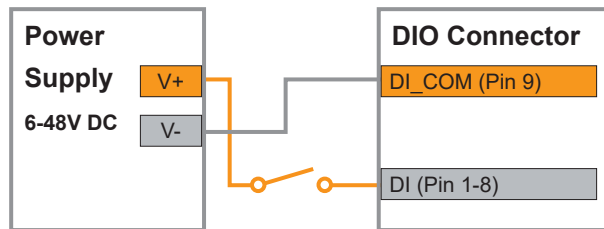

DO reference circuit :

Sink Mode  
(NPN, Default)

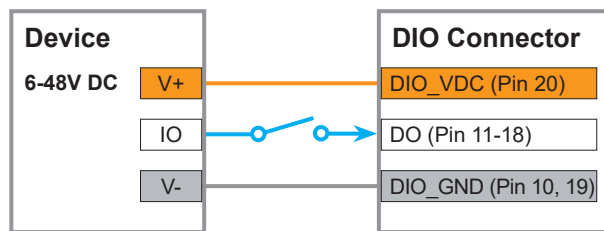

Source Mode  
(PNP)

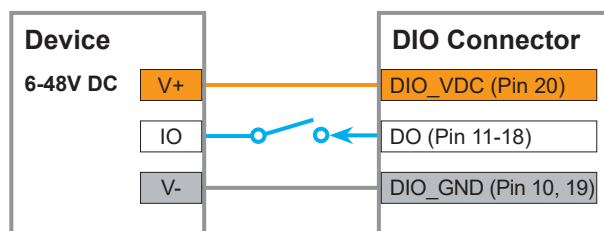

## A.3 Software Package Contain

Distribution folder include x32 and x64 versions, use the batch file for driver installation.

There are included as followed :

Win10\_32.bat, and Win10\_64.bat :

Installation for driver, and

Uninstall\_32.bat, and Uninstall\_64.bat :

Uninstallation for driver

Run batch file as Administrator.









Make sure Windows version before installation.

Header folder include head file for software developer or System Integration.

Manual folder include API description.

Sample folder include sample program, driver library, and API library for Windows/Linux

Source folder include sample program source code that compile on Visual Studio 2008/ubuntu16.04.

-  Distribution
-  Header
-  Manual
-  Sample
-  Source
-  Uninstall\_32.bat
-  Uninstall\_64.bat
-  Win10\_32.bat
-  Win10\_64.bat

## A.4 Sample

Execute demo tool.

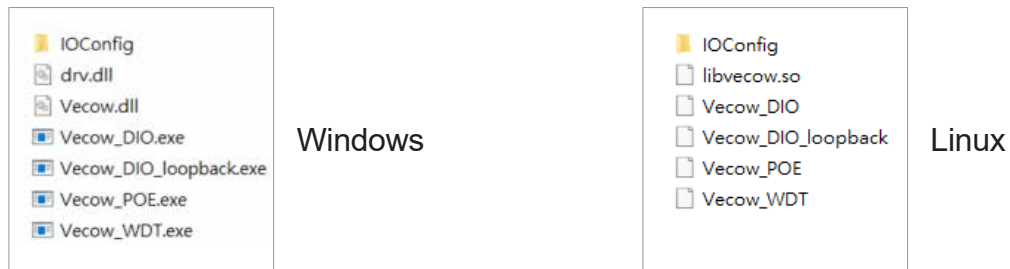

### A.4.1 DIO Sample

#### A.4.1.1 Auto load SIO configuration(.\\IOConfig\\ machine series) and initial SIO then choosing IO port you want to control.

```
DIO sample version : v1.0.0609.0608
Load Vecow.dll at least v1.8.1409.0608
Vecow.dll Version : v1.8.1409.0608
Config : IO port I - Isolated DIO
         IO port II - Non-Isolated DIO(GPIO)

Choose IO : (1/2)
```

#### A.4.1.2 Select IO port mode(see Config).

```
C:\Users\van\Desktop\sample_08.1018\x64\Vecow_DIO.exe
DIO sample version : v1.0.0208.1018
Load Vecow.dll at least v1.0.1008.0812
Vecow.dll Version : v1.3.5008.1008
Config : IO port I - Isolated DIO
         IO port II - Isolated DIO

Initial SIO success!
Choose IO : (1/2) 2
Get initial IO config success!
Select Non-Isolated/Isolated mode : (0/1)
```



#### A.4.1.2.1 Isolated DIO access then choose DI or DO access.

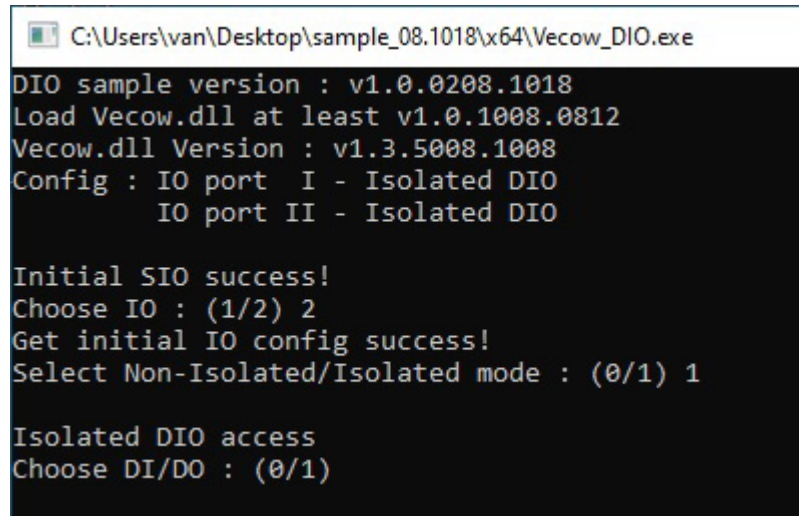

```
C:\Users\van\Desktop\sample_08.1018\x64\Vecow_DIO.exe
DIO sample version : v1.0.0208.1018
Load Vecow.dll at least v1.0.1008.0812
Vecow.dll Version : v1.3.5008.1008
Config : IO port I - Isolated DIO
         IO port II - Isolated DIO

Initial SIO success!
Choose IO : (1/2) 2
Get initial IO config success!
Select Non-Isolated/Isolated mode : (0/1) 1

Isolated DIO access
Choose DI/DO : (0/1)
```

Figure. Isolated DIO access.

#### Step 1 DI access and set DI mode(sink or source).

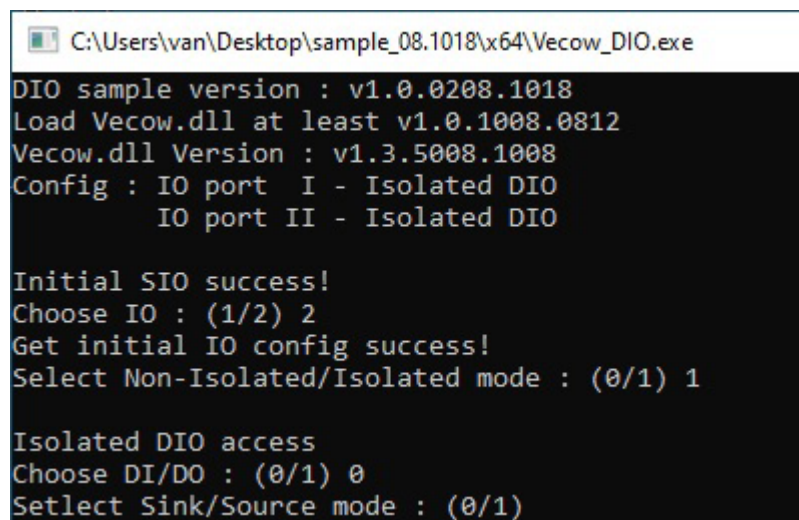

```
C:\Users\van\Desktop\sample_08.1018\x64\Vecow_DIO.exe
DIO sample version : v1.0.0208.1018
Load Vecow.dll at least v1.0.1008.0812
Vecow.dll Version : v1.3.5008.1008
Config : IO port I - Isolated DIO
         IO port II - Isolated DIO

Initial SIO success!
Choose IO : (1/2) 2
Get initial IO config success!
Select Non-Isolated/Isolated mode : (0/1) 1

Isolated DIO access
Choose DI/DO : (0/1) 0
Setlect Sink/Source mode : (0/1)
```

Figure. Get DI sink/source mode data

```
C:\Users\van\Desktop\sample_08.1018\x64\Vecow_DIO.exe
DIO sample version : v1.0.0208.1018
Load Vecow.dll at least v1.0.1008.0812
Vecow.dll Version : v1.3.5008.1008
Config : IO port I - Isolated DIO
         IO port II - Isolated DIO

Initial SIO success!
Choose IO : (1/2) 2
Get initial IO config success!
Select Non-Isolated/Isolated mode : (0/1) 1

Isolated DIO access
Choose DI/DO : (0/1) 0
Setlect Sink/Source mode : (0/1) 0
Set DIO config success!
Get DI & DO data success!
Get DI2 data = 00
Press any key to continue . . .
```

Figure. DI sink mode data.

```
E:\sample_08.1018\x64\Vecow_DIO.exe
DIO sample version : v1.0.0208.1018
Load Vecow.dll at least v1.0.1008.0812
Vecow.dll Version : v1.3.5008.1008
Config : IO port I - Isolated DIO
         IO port II - Isolated DIO

Initial SIO success!
Choose IO : (1/2) 2
Get initial IO config success!
Select Non-Isolated/Isolated mode : (0/1) 1

Isolated DIO access
Choose DI/DO : (0/1) 0
Setlect Sink/Source mode : (0/1) 1
Set DIO config success!
Get DI & DO data success!
Get DI2 data = FF
Press any key to continue . . .
```

Figure. DI source mode data.

**Step 2** DO access and set DO mode (sink or source).

```
E:\sample_08.1018\x64\Vecow_DIO.exe
DIO sample version : v1.0.0208.1018
Load Vecow.dll at least v1.0.1008.0812
Vecow.dll Version : v1.3.5008.1008
Config : IO port I - Isolated DIO
         IO port II - Isolated DIO

Initial SIO success!
Choose IO : (1/2) 2
Get initial IO config success!
Select Non-Isolated/Isolated mode : (0/1) 1

Isolated DIO access
Choose DI/DO : (0/1) 1
Setlect Sink/Source mode : (0/1)
```

Figure. Get DI sink/source mode data

**Step 2.1** Choose DO port.

```
E:\sample_08.1018\x64\Vecow_DIO.exe
DIO sample version : v1.0.0208.1018
Load Vecow.dll at least v1.0.1008.0812
Vecow.dll Version : v1.3.5008.1008
Config : IO port I - Isolated DIO
         IO port II - Isolated DIO

Initial SIO success!
Choose IO : (1/2) 2
Get initial IO config success!
Select Non-Isolated/Isolated mode : (0/1) 1

Isolated DIO access
Choose DI/DO : (0/1) 1
Setlect Sink/Source mode : (0/1) 0
Set DIO config success!
Get DI & DO data success!
Choose DO port : (1~8, 9 = All port)
```

## Step 2.2 Set DO high or low then show message.

```
E:\sample_08.1018\x64\Vecow_DIO.exe
DIO sample version : v1.0.0208.1018
Load Vecow.dll at least v1.0.1008.0812
Vecow.dll Version : v1.3.5008.1008
Config : IO port I - Isolated DIO
         IO port II - Isolated DIO

Initial SIO success!
Choose IO : (1/2) 2
Get initial IO config success!
Select Non-Isolated/Isolated mode : (0/1) 1

Isolated DIO access
Choose DI/DO : (0/1) 1
Setlect Sink/Source mode : (0/1) 0
Set DIO config success!
Get DI & DO data success!
Choose DO port : (1~8, 9 = All port) 9
Set High/Low : (0/1)
```

## A.4.1.2.2 GPIO access and set GPIO configuration.

```
C:\Users\van\Desktop\sample_08.1018\x64\Vecow_DIO.exe
DIO sample version : v1.0.0308.1108
Load Vecow.dll at least v1.0.1008.0812
Vecow.dll Version : v1.3.5008.1008
Config : IO port I - Isolated DIO
         IO port II - Non-Isolated DIO(GPIO)

Initial SIO success!
Choose IO : (1/2) 2
Get initial IO config success!
Select Non-Isolated/Isolated mode : (0/1) 0

GPIO access
Current GPIO config : 0xFF00
Set GPIO config In/Out(0/1) : 0x
```

**Step 1** Example : Set GPIO configuration 0xFF00 and get GPIO data(loopback test).

```
C:\Users\van\Desktop\sample_08.1018\x64\Vecow_DIO.exe
DIO sample version : v1.0.0308.1108
Load Vecow.dll at least v1.0.1008.0812
Vecow.dll Version : v1.3.5008.1008
Config : IO port I - Isolated DIO
         IO port II - Non-Isolated DIO(GPIO)

Initial SIO success!
Choose IO : (1/2) 2
Get initial IO config success!
Select Non-Isolated/Isolated mode : (0/1) 0

GPIO access
Current GPIO config : 0xFF00
Set GPIO config In/Out(0/1) : 0xFF00
Set GPIO config success!
Get GPIO data success!
Current GPIO data : 0x1212
Set GPIO data : 0x
```

**Step 2** Set GPIO data 0x4321 and get GPIO data(loopback test).

```
C:\Users\van\Desktop\sample_08.1018\x64\Vecow_DIO.exe
DIO sample version : v1.0.0308.1108
Load Vecow.dll at least v1.0.1008.0812
Vecow.dll Version : v1.3.5008.1008
Config : IO port I - Isolated DIO
         IO port II - Non-Isolated DIO(GPIO)

Initial SIO success!
Choose IO : (1/2) 2
Get initial IO config success!
Select Non-Isolated/Isolated mode : (0/1) 0

GPIO access
Current GPIO config : 0xFF00
Set GPIO config In/Out(0/1) : 0xFF00
Set GPIO config success!
Get GPIO data success!
Current GPIO data : 0x1212
Set GPIO data : 0x4321
Set GPIO data success!
GPIO data : 0x4343
Press any key to continue . . .
```

## A.4.2 DIO Loopback Test

To use the Vecow\_DIO\_loopback function, a test fixture is required. For the detailed connection method of the test fixture, please refer to the relevant documents of vecow.

**Step 1** Please select Vecow\_DIO\_loopback

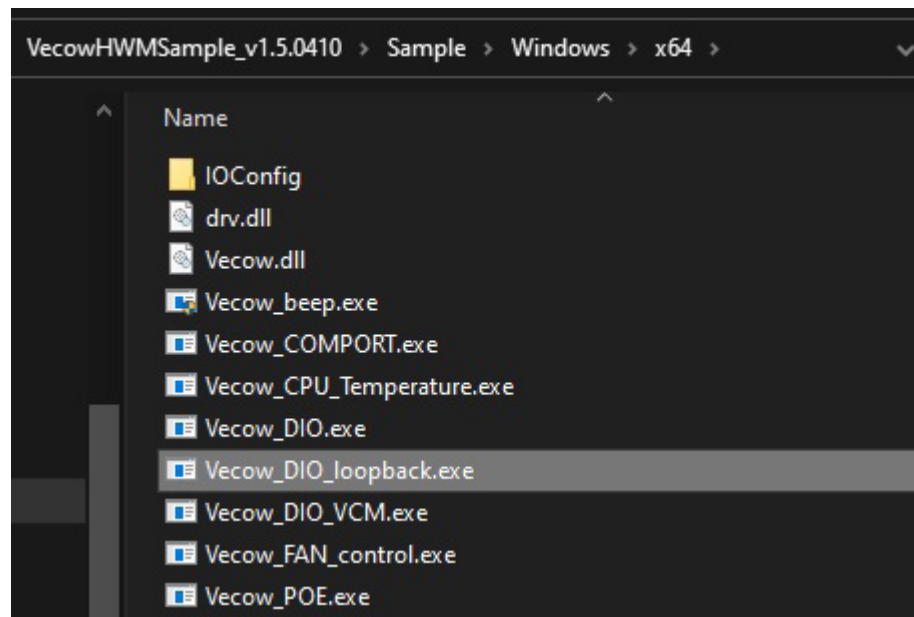

**Step 2** Please select the mode to test

```
C:\Users\CFL1909\Desktop\VecowHWMSample_v1.5.0410\VecowHWMSample_v1.5.0410\S:  
DIO loopback sample version : v1.1.0406  
Load Vecow.dll at least v1.9.0331  
Vecow.dll Version : v1.26.0413.0000  
PCB_ver = A  
How many IO temp_port : (1/2) 1  
Select Non-Isolated(GPIO)/Isolated mode : (0/1) 1  
Setlect DO Sink(NPN)/Source mode(PNP) : (0/1) 0
```

**Step 3** A normal test will continue to send data from DO, and DI will receive the same data and execute it repeatedly (the test will not stop).

```
C:\Users\CFL1909\Desktop\VecowHWMSample_v1.5.0410\VecowHWMSample_v1.5  
DI1 = 0x80  
DI check = 0x80  
  
DO = 0x81  
DI1 = 0x81  
DI check = 0x81  
  
DO = 0x82  
DI1 = 0x82  
DI check = 0x82  
  
DO = 0x83  
DI1 = 0x83  
DI check = 0x83  
  
DO = 0x84  
DI1 = 0x84  
DI check = 0x84  
  
DO = 0x85  
DI1 = 0x85  
DI check = 0x85  
  
DO = 0x86  
DI1 = 0x86  
DI check = 0x86  
  
DO = 0x87  
DI1 = 0x87
```

**Step 4** When the test is wrong, it will stop the test after 6 consecutive tests and display an error message.

```
C:\Users\CFL1909\Desktop\VecowHWMSample_v1.5.041
Set DIO config success!

DO = 0x00
DI1 = 0xff
DI check = 0x00

DO = 0x01
DI1 = 0xff
DI check = 0x01

DO = 0x02
DI1 = 0xff
DI check = 0x02

DO = 0x03
DI1 = 0xff
DI check = 0x03

DO = 0x04
DI1 = 0xff
DI check = 0x04

DO = 0x05
DI1 = 0xff
DI check = 0x05

IO port 1 error 6 times
Sat Jun 18 00:36:24 2185
```



### A.4.3 POE

**Step 1** Initial POE and auto detected useful slave address ID.

```
Select C:\Users\van\Desktop\1111\Vecow_POE.exe
POE sample version : v1.0.1408.1112
Load Vecow.dll at least v1.0.1008.0812
Vecow.dll Version : v1.4.6108.1114

Initial POE success!
Usable slave address ID : 0
Select slave address ID :
```

**Step 2** Choose useful slave address ID and show its address, then choose POE port that you want to control.

```
C:\Users\van\Desktop\1111\Vecow_POE.exe
POE sample version : v1.0.1408.1112
Load Vecow.dll at least v1.0.1008.0812
Vecow.dll Version : v1.4.6108.1114

Initial POE success!
Usable slave address ID : 0
Select slave address ID : 0
Salve address : 0x40
Choose POE port : (0~3, 4 = All port)
```

**Step 3** Set Manual or Auto mode.

```
C:\Users\van\Desktop\1111\Vecow_POE.exe
POE sample version : v1.0.1408.1112
Load Vecow.dll at least v1.0.1008.0812
Vecow.dll Version : v1.4.6108.1114

Initial POE success!
Usable slave address ID : 0
Select slave address ID : 0
Salve address : 0x40
Choose POE port : (0~3, 4 = All port) 4
Set Manual/Auto mode : (0/1)
```

**Step 3.1** Set Auto mode and show success message.

```
C:\Users\van\Desktop\1111\Vecow_POE.exe
POE sample version : v1.0.1408.1112
Load Vecow.dll at least v1.0.1008.0812
Vecow.dll Version : v1.4.6108.1114

Initial POE success!
Usable slave address ID : 0
Select slave address ID : 0
Salve address : 0x40
Choose POE port : (0~3, 4 = All port) 4
Set Manual/Auto mode : (0/1) 1
Set Auto mode success!
Press any key to continue . . .
```

**Step 3.2** Set Manual mode and then turn OF/OFF POE port.

```
Select C:\Users\van\Desktop\1111\Vecow_POE.exe
POE sample version : v1.0.1408.1112
Load Vecow.dll at least v1.0.1008.0812
Vecow.dll Version : v1.4.6108.1114

Initial POE success!
Usable slave address ID : 0
Select slave address ID : 0
Salve address : 0x40
Choose POE port : (0~3, 4 = All port) 4
Set Manual/Auto mode : (0/1) 0
Set Manual mode success!
Set POE port OFF/ON : (0/1)
```

**Step 3.3** Set POE port success message.

```
C:\Users\van\Desktop\1111\Vecow_POE.exe
POE sample version : v1.0.1408.1112
Load Vecow.dll at least v1.0.1008.0812
Vecow.dll Version : v1.4.6108.1114

Initial POE success!
Usable slave address ID : 0
Select slave address ID : 0
Salve address : 0x40
Choose POE port : (0~3, 4 = All port) 4
Set Manual/Auto mode : (0/1) 0
Set Manual mode success!
Set POE port OFF/ON : (0/1) 1
Set POE success!
Press any key to continue . . .
```

## A.4.4 WDT

### A.4.4.1 WDT once

**Step 1** Auto load SIO configuration and initial SIO then set WDT seconds.

```
C:\Users\van\Desktop\sample_08.1018\x64\Vecow_WDT.exe
WDT sample version : v1.0.0208.1018
Load Vecow.dll at least v1.0.1008.0812
Vecow.dll Version : v1.3.5008.1008
Config : IO port I - Isolated DIO
         IO port II - Isolated DIO

Initial SIO success!
Get initial WDT success!
Set WDT timer seconds (1~3932100) :
```

**Step 2** Set WDT success message.

```
C:\Users\van\Desktop\sample_08.1018\x64\Vecow_WDT.exe
WDT sample version : v1.0.0208.1018
Load Vecow.dll at least v1.0.1008.0812
Vecow.dll Version : v1.3.5008.1008
Config : IO port I - Isolated DIO
         IO port II - Isolated DIO

Initial SIO success!
Get initial WDT success!
Set WDT timer seconds (1~3932100) : 10
Set WDT success!
```

**Step 3** Time out message.

```
C:\Users\van\Desktop\sample_08.1018\x64\Vecow_WDT.exe
WDT sample version : v1.0.0208.1018
Load Vecow.dll at least v1.0.1008.0812
Vecow.dll Version : v1.3.5008.1008
Config : IO port I - Isolated DIO
         IO port II - Isolated DIO

Initial SIO success!
Get initial WDT success!
Set WDT timer seconds (1~3932100) : 10
Set WDT success!
if reboot, WDT out early
if reboot, WDT out in range
if reboot, WDT out late
```

## A.4.5 WDT LOOP

**Step 1** Auto load SIO configuration and initial SIO then set WDT loop seconds.

```
C:\Users\van\Desktop\sample_08.1018\x64\Vecow_WDT_loop.exe
WDT loop sample version : v1.0.0108.1018
Load Vecow.dll at least v1.0.1008.0812
Vecow.dll Version : v1.3.5008.1008
Config : IO port I - Isolated DIO
         IO port II - Isolated DIO

Initial SIO success!
Get initial WDT success!
Set WDT timer loop seconds (1~3932100) :
```

**Step 2** 80% WDT time will rest WDT again, if close .exe will reboot.

```
C:\Users\van\Desktop\sample_08.1018\x64\Vecow_WDT_loop.exe
WDT loop sample version : v1.0.0108.1018
Load Vecow.dll at least v1.0.1008.0812
Vecow.dll Version : v1.3.5008.1008
Config : IO port I - Isolated DIO
         IO port II - Isolated DIO

Initial SIO success!
Get initial WDT success!
Set WDT timer loop seconds (1~3932100) : 10
Set WDT success!
Set WDT success!
Set WDT success!
Set WDT success!
Set WDT success!
Set WDT success!
Set WDT success!
```

# B

## APPENDIX B : Software Functions

### B.1 Driver API Guide

In Header folder, Vecow.h and VecowLinux.h contain usable API for Windows/Linux.

#### **BOOL initial\_SIO(BYTE Isolate\_Type, BYTE DIO\_NPN)**

Initial machine for IO and watch dogtimer.

Isolate\_Type : DIO type.

1 : Isolated DIO;

0 : Non-Isolated DIO(GPIO).

DIO\_NPN : DI/DO type.

1 : PNP (Source) mode for European rule;

0 : NPN (Sink) mode for Japanese rule.

Return :

TRUE (1) : Success.

FALSE (0) : Fail (Driver not exists, or version is too old, or machine not match).

#### **BOOL get\_IO1\_configuration(BYTE \*Iso, BYTE \*DI\_mode, BYTE \*DO\_mode, WORD \*Mask)**

#### **BOOL get\_IO2\_configuration(BYTE \*Iso, BYTE \*DI\_mode, BYTE \*DO\_mode, WORD \*Mask)**

Get DIO configuration (by variable)

Isolate\_Type : DIO type.

1 : Isolated DIO;

0 : Non-Isolated DIO(GPIO).

DI\_mode ([7:0]) : DI type, pin setting by hexadecimal bitmask only for Isolated DIO.

0xFF : PNP (Source) mode for European rule;

0 : NPN (Sink) mode for Japanese rule.

DO\_mode : DO type only for Isolated DIO.

1 : PNP (Source) mode for European rule;

0 : NPN (Sink) mode for Japanese rule.

Mask ([15:0]) : In/Out, pin setting by hexadecimal bitmask only for Non-Isolated DIO(GPIO).

1 : Output;

0 : Input

Return :

TRUE (1) : Success.

FALSE (0) : Fail (Initial error, or call by pointer error, or hardware problem).

**BOOL set\_IO1\_configuration(BYTE Iso, BYTE DI\_mode, BYTE DO\_mode, WORD Mask)**

**BOOL set\_IO2\_configuration(BYTE Iso, BYTE DI\_mode, BYTE DO\_mode, WORD Mask)**

Set DIO configuration.

Isolate\_Type : DIO type.

1 : Isolated DIO;

0 : Non-Isolated DIO (GPIO).

DI\_mode ([7:0]) : DI type, pin setting by hexadecimal bitmask only for Isolated DIO.

0xFF : PNP (Source) mode for European rule;

0 : NPN (Sink) mode for Japanese rule.

DO\_mode : DO type only for Isolated DIO.

1 : PNP (Source) mode for European rule;

0 : NPN (Sink) mode for Japanese rule.

Mask ([15:0]) : In/Out, pin setting by hexadecimal bitmask only for Non-Isolated DIO (GPIO).

1 : Output;

0 : Input

Return :

TRUE (1) : Success.

FALSE (0) : Fail (Initial error or hardware problem).

**BOOL get\_DIO1(BYTE \*DO\_data, BYTE \*DI\_data)**

**BOOL get\_DIO2(BYTE \*DO\_data, BYTE \*DI\_data)**

Get isolated DIO output(DO) and input (DI).

DI ([7:0]) : Input state, pin setting by hexadecimal bitmask.

1 : High;

0 : Low.

DO ([7:0]) : Output state, pin setting by hexadecimal bitmask.

1 : High;

0 : Low.

Return :

TRUE (1) : Success.

FALSE (0) : Fail (Initial error or hardware problem).

FALSE (0) : Fail (Initial error or hardware problem).

**BOOL set\_DIO1(BYTE DO\_data)**

**BOOL set\_DIO2(BYTE DO\_data)**

Set isolated DIO output(DO).

DO ([7:0]) : Output state, pin setting by hexadecimal bitmask.

1 : High;

0 : Low.

Return :

TRUE (1) : Success.

FALSE (0) : Fail (Initial error or hardware problem).

FALSE (0) : Fail (Initial error or hardware problem).

**BOOL get\_GPIO1(WORD \*GPIO\_data)**

Get GPIO.

GPIO\_data ([15:0]) : GPIO state, pin setting by hexadecimal bitmask.  
1 : High;  
0 : Low.

Return :

TRUE (1) : Success.  
FALSE (0) : Fail (Initial error or hardware problem).

**BOOL get\_WDT(DWORD \*WDT)**

Get watchdog timer setup.

WDT : watchdog timer setup.  
Unit : second (Range : 0 ~ 65535 sec, 1093 ~ 65535 min (=65580 ~ 3932100 sec)).

Return :

TRUE (1) : Success.  
FALSE (0) : Fail (Initial error, or call by pointer error, or hardware problem).

**BOOL set\_WDT(DWORD WDT)**

Set watchdog timer setup.

WDT : watchdog timer setup.  
Unit : second (Range : 0 ~ 65535 sec, 1093 ~ 65535 min (=65580 ~ 3932100 sec)).

Return :

TRUE (1) : Success.  
FALSE (0) : Fail (Initial error, or setup 0, or hardware problem).

**BOOL cancel\_WDT()**

Cancel watchdog timer.

Return :

TRUE (1) : Success.  
FALSE (0) : Fail (Initial error or hardware problem).

**BOOL initial\_POE(BYTE Scan, BYTE ID)**

Initial POE.

Scan : POEID scan type  
2 : Auto scan; 1 : Manual setup.  
ID : POE ID by manual setting.  
Range : 0~15.

Return :

TRUE (1) : Success.  
FALSE (0) : Fail (Driver not exists, or version is too old, or out of range error).

**BOOL get\_POE\_configuration(BYTE ID, BYTE \*Auto, BYTE \*Mask)**

Get POE configuration (by variable).

ID : POE ID.  
Range : 0~15.  
Auto ([3:0]) : Auto mode, pin setting by hexadecimal bitmask.

1 : Auto;  
0 : Manual.  
Mask ([3:0]) : DC Enable/Disable, pin setting by hexadecimal bitmask.  
1 : Enable;  
0 : Disable.

Return :

TRUE (1) : Success.

FALSE (0) : Fail (Initial error, or out of range error, or call by pointer error, or hardware problem)

### **BOOL set\_POE\_configuration(BYTE ID, BYTE Auto, BYTE Mask)**

Set POE configuration (by variable).

ID : POE ID.

Range : 0~15.

Auto ([3:0]) : Auto mode, pin setting by hexadecimal bitmask.

1 : Auto;

0 : Manual.

Mask ([3:0]) : DC Enable/Disable, pin setting by hexadecimal bitmask.

1 : Enable;

0 : Disable.

Return :

TRUE (1) : Success.

FALSE (0) : Fail (Initial error, or out of range error, or hardware problem).

### **BOOL get\_POE(BYTE ID, BYTE \*POE)**

Get POE state.

ID : POE ID.

Range : 0~15.

POE ([3:0]) : POE state, pin setting by hexadecimal bitmask.

1 : On;

0 : Off.

Return :

TRUE (1) : Success.

FALSE (0) : Fail (Initial error, or out of range error, or call by pointer error, or hardware problem).

### **BOOL set\_POE(BYTE ID, BYTE POE)**

Set POE state.

A. ID : POE ID.

Range : 0~15.

B. POE ([3:0]) : POE state, pin setting by hexadecimal bitmask.

1 : On;

0 : Off.

Return :

TRUE (1) : Success.

FALSE (0) : Fail (Initial error, or out of range error, or hardware problem).



# C

## APPENDIX C : RAID Functions

### C.1.1 VMD Controller for RAID

Please set Enable VMD controller as Enabled on BIOS menu.

Chipset → System Agent (SA) Configuration → Enable VMD controller → Enabled → Save Changes and Reset.

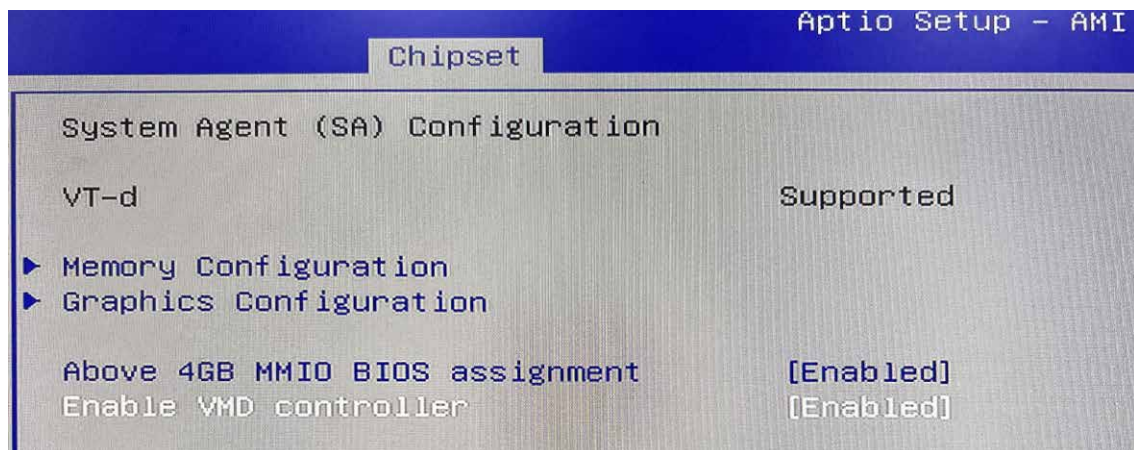

### C.1.2 UEFI Mode for RAID

1. Into BIOS menu again, select Intel(R) Rapid Storage Technology on BIOS menu.

Advanced → Intel(R) Rapid Storage Technology

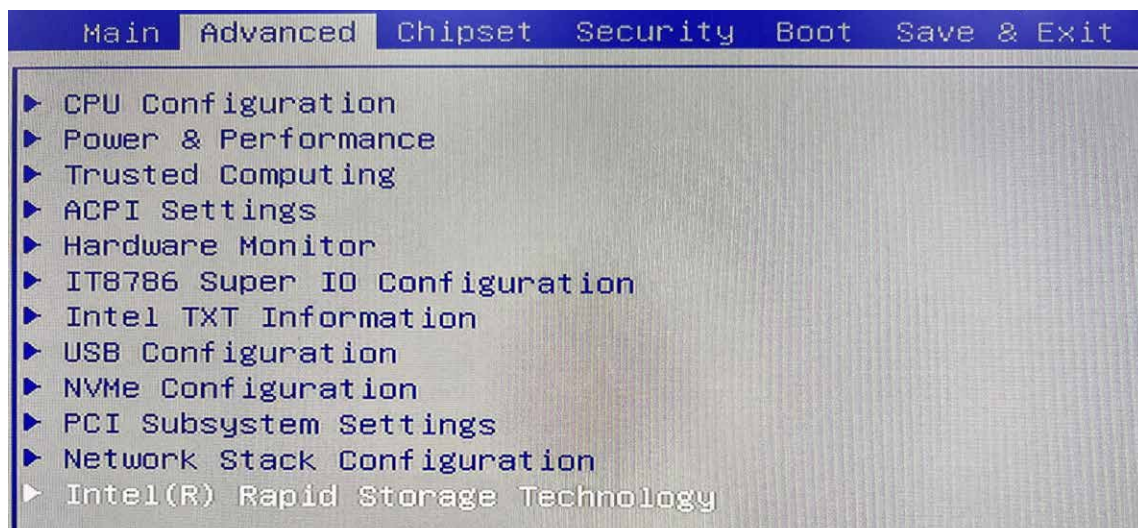

2. Select Create RAID Volume on BIOS menu.

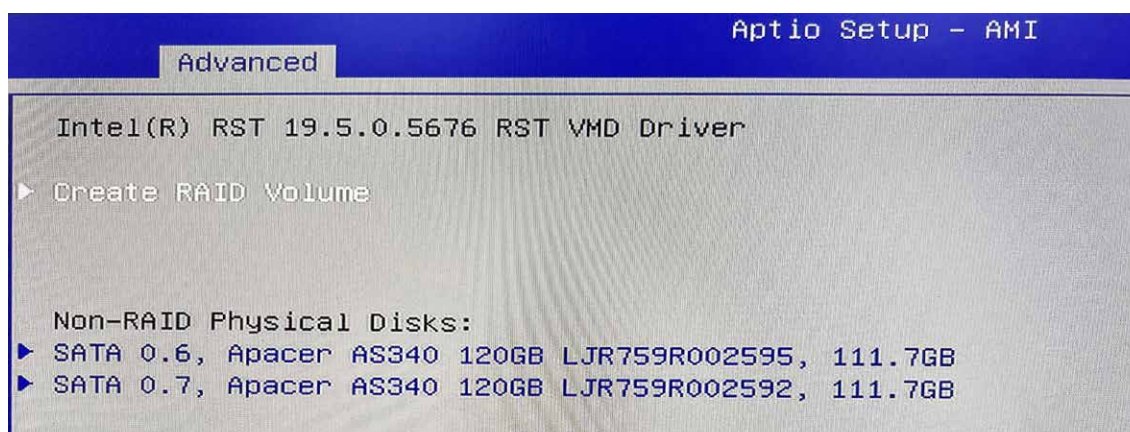

3. Select disks to create RAID Volume then Save Changes and Reset to install OS with EFI mode.

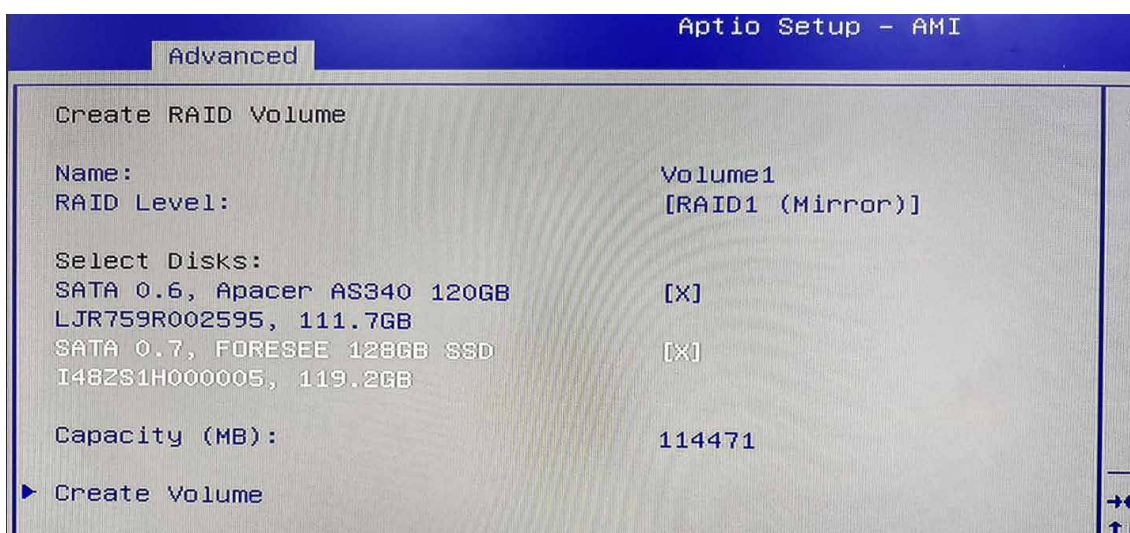

## C.2 OS Installation

The system is featured with one M.2 key M for NVME, one mSATA slot, and including two internal SATA.

We used SATA for Windows 10 OS installation as an example.

Note:

ECX-3100 PEG, ECX-3200 PEG, ECX-3200MX PEG are equipped with 2 SATA.  
ECX-3400 PEG, ECX-3600 PEG, ECX-3800 PEG are equipped with 4 SATA.

## C.3 To Install All Device Drivers of the System

The instructions are as follows :

1. Install Chipset driver
2. Install Network driver
3. Install ME driver (if available)
4. Install Audio driver
5. Install VGA driver

## C.4 To Install "Intel Rapid Storage Technology" Software

You can find the latest information and software directly from Intel's website.

[http://www.intel.com/p/en\\_US/support/highlights/chpsts/ims](http://www.intel.com/p/en_US/support/highlights/chpsts/ims)

The RAID environment has been done if you completed the steps above.

## C.5 To Insert SATA HDD for RAID 1

Please note, you can use two SATA ports for SATA HDD, except for mSATA slot.

## C.6 To Create RAID Volume on "Rapid Storage Technology" Software

ECX-3000 PEG is featured with two SATA HDD's for RAID volume, so there are two options to choose on this page. Let's take RAID 1 as an example, select "RAID 1".



## C.7 Disk Management : Partition the Disk

After RAID 1 volume is created, you can see the figure of SATA device allocation.

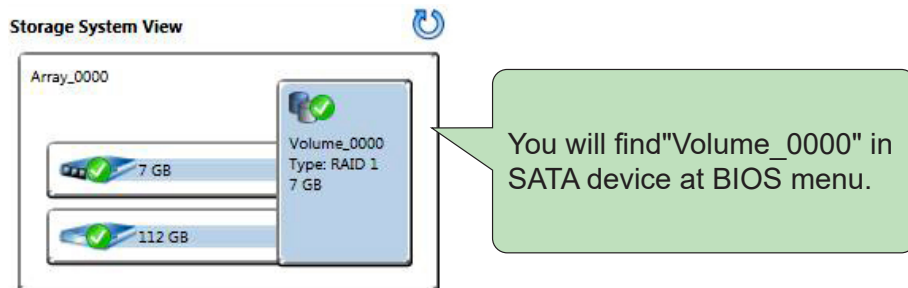

To start disk management tool, select "initialize disk".  
 Then add "Logical Device" for Windows access.

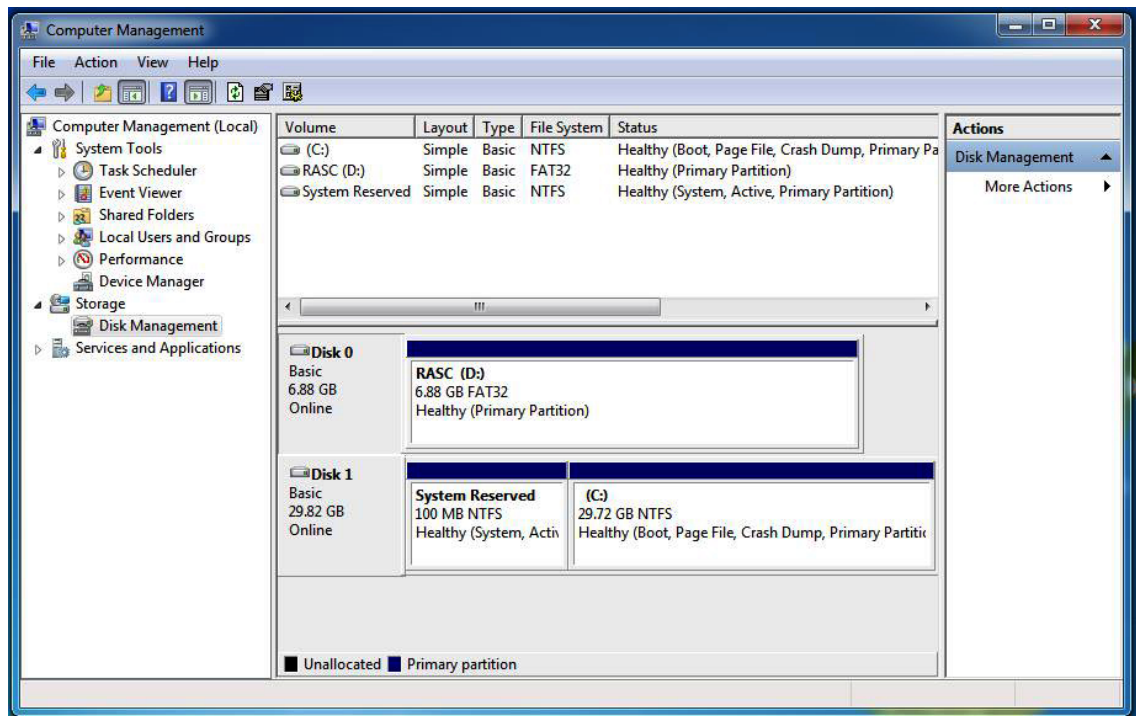

## C.8 If One SATA HDD on RAID Volume is Out-of-use

After RAID 1 volume is created, you can see the figure of SATA device allocation.

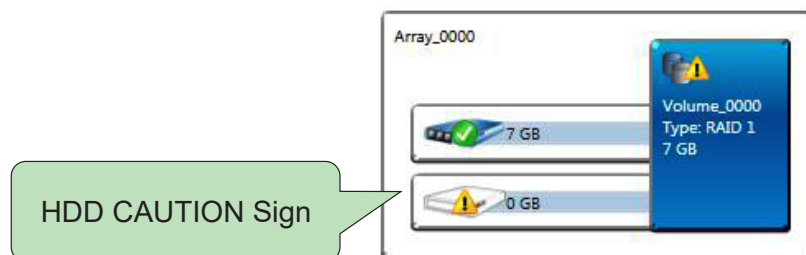

## C.9 Recovery and Auto Rebuild When Use the **SAME** RAID HDD

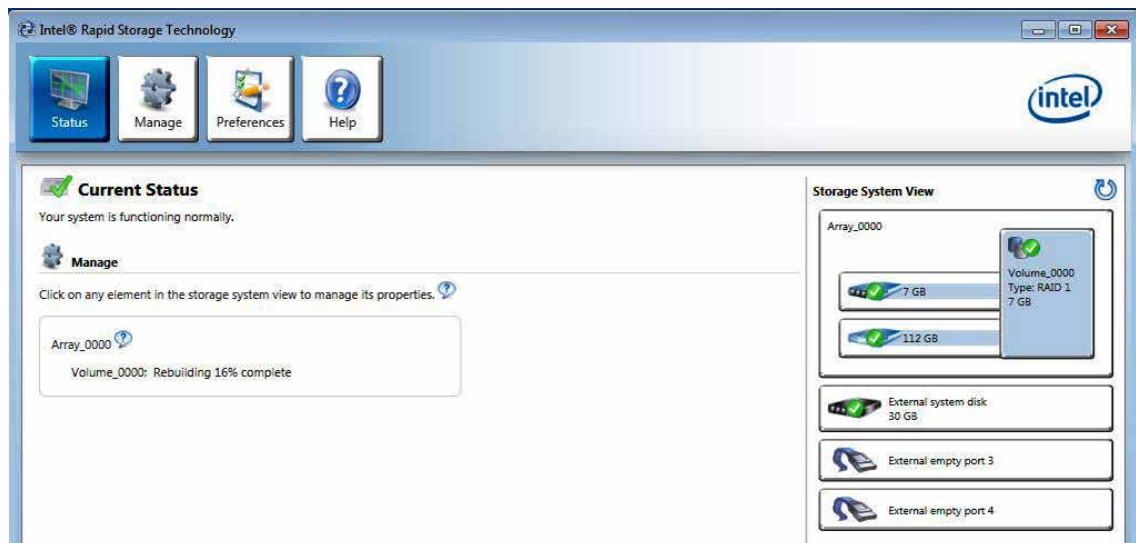

## C.10 Recovery and Auto Rebuild When Use **DIFFERENT** RAID HDD

A warning will pop-up to ask you if the disk is not a member of the original RAID volume.

If you press "Rebuild", it will replace the broken SATA HDD to the last SATA HDD of RAID volume.

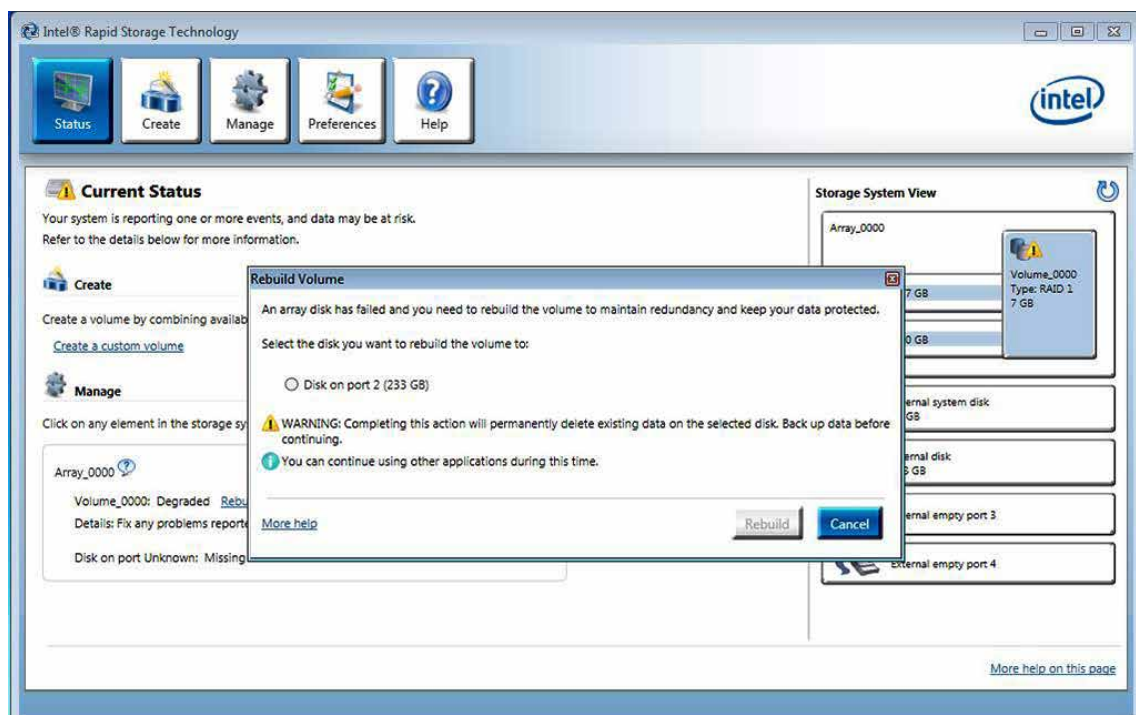

# D

## APPENDIX D : Power Consumption

| Testing Board   | ECX-3000PEG                      |
|-----------------|----------------------------------|
| RAM             | 32GB * 2                         |
| USB-1           | USB Microsoft Wired Keyboard 600 |
| USB-2           | USB Mouse HP G1K28AA             |
| USB-3           | USB Flash Transecnd 3.0 16GB     |
| USB-4           | USB Flash Transecnd 3.0 16GB     |
| SATA 0          | Transcend SATA SSD420 128GB      |
| SATA 1          | Seagate HDD 500GB                |
| LAN1 (i219)     | 1.0 Gbps                         |
| LAN2 (i210)     | 1.0 Gbps                         |
| LAN3 (i226-IT)  | 2.5 Gbps                         |
| LAN4 (i226-IT)  | 2.5 Gbps                         |
| LAN5 (i226-IT)  | 2.5 Gbps                         |
| LAN6 (i226-IT)  | 2.5 Gbps                         |
| Graphics output | HDMI                             |
| Power plan      | Balance(Windows10 Power plan)    |
| Power Source :  | Chroma 62006P-100-25             |
| Test Program-1  | BurnInTest                       |

## D.1 Intel® Core i7-12700TE 1.40 GHz (25M Cache, up to 4.60 GHz)

Power on and boot to Win 10 (64-bit)

| CPU                    | Power Input | Standby Mode |                 | Power on and boot to Win 10 (64-bit) |                 |                               |                 |
|------------------------|-------------|--------------|-----------------|--------------------------------------|-----------------|-------------------------------|-----------------|
|                        |             |              |                 | Sleep Mode                           |                 | idle status CPU usage less 3% |                 |
|                        |             | Max Current  | Max Consumption | Max Current                          | Max Consumption | Max Current                   | Max Consumption |
| Intel® Core i7-12700TE | 9V          | 0.528A       | 04.76W          | 0.678A                               | 06.10W          | 3.004A                        | 27.04W          |
| Intel® Core i7-12700TE | 12V         | 0.449A       | 05.39W          | 0.516A                               | 06.19W          | 2.435A                        | 29.22W          |
| Intel® Core i7-12700TE | 24V         | 0.352A       | 08.44W          | 0.390A                               | 09.36W          | 1.242A                        | 29.81W          |
| Intel® Core i7-12700TE | 50V         | 0.257A       | 12.84W          | 0.303A                               | 15.13W          | 0.889A                        | 44.46W          |

| CPU                    | Power Input | Power on and boot to Win10 (64-bit) |                 |                            |                 |
|------------------------|-------------|-------------------------------------|-----------------|----------------------------|-----------------|
|                        |             | Run 100% CPU usage with 2D          |                 | Run 100% CPU usage with 3D |                 |
|                        |             | Max Current                         | Max Consumption | Max Current                | Max Consumption |
| Intel® Core i7-12700TE | 9V          | 6.735A                              | 60.62W          | 9.468A                     | 85.21W          |
| Intel® Core i7-12700TE | 12V         | 4.963A                              | 59.56W          | 6.725A                     | 80.70W          |
| Intel® Core i7-12700TE | 24V         | 2.414A                              | 57.94W          | 3.467A                     | 83.21W          |
| Intel® Core i7-12700TE | 50V         | 1.504A                              | 75.18W          | 1.951A                     | 97.54W          |



## D.2 Intel® Core i9-12900E 2.30 GHz (30M Cache, up to 5.00 GHz)

Power on and boot to Win 10 (64-bit)

| CPU                   | Power Input | Standby Mode |                 | Power on and boot to Win 10 (64-bit) |                 |                               |                 |
|-----------------------|-------------|--------------|-----------------|--------------------------------------|-----------------|-------------------------------|-----------------|
|                       |             |              |                 | Sleep Mode                           |                 | idle status CPU usage less 3% |                 |
|                       |             | Max Current  | Max Consumption | Max Current                          | Max Consumption | Max Current                   | Max Consumption |
| Intel® Core i9-12900E | 9V          | 0.593A       | 05.34W          | 0.747A                               | 06.72W          | 4.984A                        | 44.85W          |
| Intel® Core i9-12900E | 12V         | 0.485A       | 05.82W          | 0.611A                               | 07.34W          | 3.677A                        | 44.12W          |
| Intel® Core i9-12900E | 24V         | 0.329A       | 07.90W          | 0.424A                               | 10.18W          | 1.939A                        | 46.53W          |
| Intel® Core i9-12900E | 50V         | 0.286A       | 14.32W          | 0.334A                               | 16.71W          | 0.932A                        | 46.58W          |

| CPU                   | Power Input | Power on and boot to Win10 (64-bit) |                 |                            |                 |
|-----------------------|-------------|-------------------------------------|-----------------|----------------------------|-----------------|
|                       |             | Run 100% CPU usage with 2D          |                 | Run 100% CPU usage with 3D |                 |
|                       |             | Max Current                         | Max Consumption | Max Current                | Max Consumption |
| Intel® Core i9-12900E | 9V          | 11.747A                             | 105.72W         | 11.019A                    | 99.17W          |
| Intel® Core i9-12900E | 12V         | 7.725A                              | 92.70W          | 7.947A                     | 95.36W          |
| Intel® Core i9-12900E | 24V         | 3.962A                              | 95.09W          | 4.949A                     | 118.77W         |
| Intel® Core i9-12900E | 50V         | 2.136A                              | 106.82W         | 2.271A                     | 113.56W         |

## D.3 Intel® Core i7-13700E 1.90 GHz (30M Cache, up to 5.10 GHz)

Power on and boot to Win 10 (64-bit)

| CPU                   | Power Input | Standby Mode |                 | Power on and boot to Win 10 (64-bit) |                 |                               |                 |
|-----------------------|-------------|--------------|-----------------|--------------------------------------|-----------------|-------------------------------|-----------------|
|                       |             |              |                 | Sleep Mode                           |                 | idle status CPU usage less 3% |                 |
|                       |             | Max Current  | Max Consumption | Max Current                          | Max Consumption | Max Current                   | Max Consumption |
| Intel® Core i7-13700E | 9V          | 0.609A       | 05.48W          | 0.752A                               | 06.77W          | 3.612A                        | 32.51W          |
| Intel® Core i7-13700E | 12V         | 0.508A       | 06.09W          | 0.599A                               | 07.18W          | 2.763A                        | 33.15W          |
| Intel® Core i7-13700E | 24V         | 0.374A       | 08.97W          | 0.417A                               | 10.02W          | 1.421A                        | 34.10W          |
| Intel® Core i7-13700E | 50V         | 0.311A       | 15.56W          | 0.331A                               | 16.55W          | 0.862A                        | 43.10W          |

| CPU                   | Power Input | Power on and boot to Win10 (64-bit) |                 |                            |                 |
|-----------------------|-------------|-------------------------------------|-----------------|----------------------------|-----------------|
|                       |             | Run 100% CPU usage with 2D          |                 | Run 100% CPU usage with 3D |                 |
|                       |             | Max Current                         | Max Consumption | Max Current                | Max Consumption |
| Intel® Core i7-13700E | 9V          | 6.990A                              | 62.91W          | 9.553A                     | 85.98W          |
| Intel® Core i7-13700E | 12V         | 5.289A                              | 63.47W          | 7.154A                     | 85.85W          |
| Intel® Core i7-13700E | 24V         | 2.521A                              | 60.50W          | 3.635A                     | 87.24W          |
| Intel® Core i7-13700E | 50V         | 1.434A                              | 71.72W          | 1.870A                     | 93.51W          |

## D.4 Intel® Core i7-13700E Add GTX 1650 Graphics Card

Power on and boot to Win 10 (64-bit)

| CPU                   | Power Input | Power on and boot to Win 10 (64-bit) |                 |             |                 |                               |                 |
|-----------------------|-------------|--------------------------------------|-----------------|-------------|-----------------|-------------------------------|-----------------|
|                       |             | Standby Mode                         |                 | Sleep Mode  |                 | idle status CPU usage less 3% |                 |
|                       |             | Max Current                          | Max Consumption | Max Current | Max Consumption | Max Current                   | Max Consumption |
| Intel® Core i7-13700E | 12V         | 0.499A                               | 05.99W          | 0.601A      | 07.21W          | 4.999A                        | 59.99W          |
| Intel® Core i7-13700E | 24V         | 0.374A                               | 08.98W          | 0.413A      | 09.91W          | 1.848A                        | 44.34W          |
| Intel® Core i7-13700E | 36V         | 0.331A                               | 11.92W          | 0.356A      | 12.82W          | 1.280A                        | 46.09W          |
| Intel® Core i7-13700E | 50V         | 0.310A                               | 15.50W          | 0.332A      | 16.61W          | 1.054A                        | 52.70W          |

| CPU                   | Power Input | Power on and boot to Win10 (64-bit) |                 |                            |                 |
|-----------------------|-------------|-------------------------------------|-----------------|----------------------------|-----------------|
|                       |             | Run 100% CPU usage with 2D          |                 | Run 100% CPU usage with 3D |                 |
|                       |             | Max Current                         | Max Consumption | Max Current                | Max Consumption |
| Intel® Core i7-13700E | 12V         | 6.173A                              | 74.07W          | 9.251A                     | 111.01W         |
| Intel® Core i7-13700E | 24V         | 3.085A                              | 74.05W          | 4.455A                     | 106.91W         |
| Intel® Core i7-13700E | 36V         | 2.105A                              | 75.77W          | 3.028A                     | 109.00W         |
| Intel® Core i7-13700E | 50V         | 1.691A                              | 84.56W          | 2.367A                     | 118.37W         |

# E

## APPENDIX E : Supported Memory & Storage List

### E.1 Test Item

|               |                 |
|---------------|-----------------|
| Testing Board | ECX-3000PEG     |
| Memory Test   | MemTest86 V10.4 |
| BurnInTest    | V9.2            |

| Channel       | Memtest | Bunin | Flash BIOS | Remove Battery |
|---------------|---------|-------|------------|----------------|
| *2            | PASS    | PASS  | PASS       | PASS           |
| *1 (Socket 1) | PASS    | PASS  | N/A        | PASS           |
| *1 (Socket 2) | PASS    | PASS  | N/A        | PASS           |

## E.2 Supported Non-ECC Memory List

| Brand                         | Info                | Test Temp. (Celsius) |
|-------------------------------|---------------------|----------------------|
| Goldkey 32G DDR5 4800 SO-DIMM | NMSO532F81-4800JA0C | 25°C                 |
| SLLINK 32G DDR5 4800 SO-DIMM  | J5BGSH2G8A4FC       | 25°C                 |
| SMART 32G DDR5 4800 SO-DIMM   | SR4G6SO5285-SB      | 25°C                 |

## E.3 Supported ECC Memory List

| Brand                          | Info                | Test Temp. (Celsius) |
|--------------------------------|---------------------|----------------------|
| Goldkey 32G DDR5 4800 SO-DIMM  | NMES532F81-4800JA0C | 25°C                 |
| SMART 32G DDR5 4800 SO-DIMM    | SR4G7SO5285-SB      | 25°C                 |
| SLLINK 32G DDR5 4800 SO-DIMM   | J5BGDH2G8A4XC       | 25°C                 |
| Innodisk 32G DDR5 4800 SO-DIMM | M5D0-BGS2QCVP-H03   | 25°C                 |

## E.4 Supported Storage Device List

| Type         | Brand     | Model                                       | Capacity |
|--------------|-----------|---|----------|
| SATA HDD     | Seagate   | SDC001                                      | 500GB    |
| SATA SSD     | Apacer    | AS340X                                      | 120GB    |
|              | SMART     | FDMP8960GTCXA111                            | 960GB    |
|              | MEMXPRO   | M3A MI3MA1212802WN                          | 128GB    |
|              | Transcend | TS128GSSD420K                               | 128GB    |
|              |           | TS128GSSD230S                               | 128GB    |
|              | Kingston  | SHFS37A                                     | 240GB    |
|              | Innodisk  | 2.5" SATA SSD 3TE4<br>DES25-A28M41BW1DC-H03 | 128GB    |
|              |           | 2.5" SATA SSD 3TG2-P<br>DGS25-64GD81BC1QC   | 64GB     |
| M.2 PCIe SSD | Toshiba   | KXG50ZNV512G                                | 512GB    |
|              | Kingston  | SA2000MB                                    | 250GB    |
|              | SAMSUNG   | 970 EVO PLUS<br>MZ-V7S250                   | 250GB    |
|              |           | 980 EVO PRO<br>MZ-V8P250BW                  | 250GB    |
|              | INTEL     | 760P<br>SSDPEKKW128G8                       | 128GB    |
|              | SMART     | FDMP8960GTCXA111                            | 960GB    |

\*\* If more help is needed, please contact Vecow Technical Support.\*\*



For further support information, please visit [www.vecow.com](http://www.vecow.com)

This document is released for reference purpose only.

All product offerings and specifications are subject to change without prior notice.

No part of this publication may be reproduced in any form or by any means, electric, photocopying, or recording, without prior authorization from the publisher.

The rights of all the brand names, product names, and trademarks belong to their respective owners.

© Vecow Co., Ltd. 2024. All rights reserved.